

Service Manual



DTG5078 & DTG5274 Data Timing Generators

071-1285-00

This document supports firmware version 1.0.14
and above.

www.tektronix.com

Copyright © Tektronix Japan, Ltd. All rights reserved.

Copyright © Tektronix, Inc. All rights reserved.

Tektronix products are covered by U.S. and foreign patents, issued and pending. Information in this publication supercedes that in all previously published material. Specifications and price change privileges reserved.

Tektronix Japan, Ltd. 5-9-31 Kitashinagawa, Shinagawa-ku, Tokyo 141-0001 Japan

Tektronix, Inc., P.O. Box 500, Beaverton, OR 97077-0001

TEKTRONIX and TEK are registered trademarks of Tektronix, Inc.

WARRANTY

Tektronix warrants that the products that it manufactures and sells will be free from defects in materials and workmanship for a period of one (1) year from the date of shipment. If a product proves defective during this warranty period, Tektronix, at its option, either will repair the defective product without charge for parts and labor, or will provide a replacement in exchange for the defective product.

In order to obtain service under this warranty, Customer must notify Tektronix of the defect before the expiration of the warranty period and make suitable arrangements for the performance of service. Customer shall be responsible for packaging and shipping the defective product to the service center designated by Tektronix, with shipping charges prepaid. Tektronix shall pay for the return of the product to Customer if the shipment is to a location within the country in which the Tektronix service center is located. Customer shall be responsible for paying all shipping charges, duties, taxes, and any other charges for products returned to any other locations.

This warranty shall not apply to any defect, failure or damage caused by improper use or improper or inadequate maintenance and care. Tektronix shall not be obligated to furnish service under this warranty a) to repair damage resulting from attempts by personnel other than Tektronix representatives to install, repair or service the product; b) to repair damage resulting from improper use or connection to incompatible equipment; c) to repair any damage or malfunction caused by the use of non-Tektronix supplies; or d) to service a product that has been modified or integrated with other products when the effect of such modification or integration increases the time or difficulty of servicing the product.

THIS WARRANTY IS GIVEN BY TEKTRONIX IN LIEU OF ANY OTHER WARRANTIES, EXPRESS OR IMPLIED. TEKTRONIX AND ITS VENDORS DISCLAIM ANY IMPLIED WARRANTIES OF MERCHANTABILITY OR FITNESS FOR A PARTICULAR PURPOSE. TEKTRONIX' RESPONSIBILITY TO REPAIR OR REPLACE DEFECTIVE PRODUCTS IS THE SOLE AND EXCLUSIVE REMEDY PROVIDED TO THE CUSTOMER FOR BREACH OF THIS WARRANTY. TEKTRONIX AND ITS VENDORS WILL NOT BE LIABLE FOR ANY INDIRECT, SPECIAL, INCIDENTAL, OR CONSEQUENTIAL DAMAGES IRRESPECTIVE OF WHETHER TEKTRONIX OR THE VENDOR HAS ADVANCE NOTICE OF THE POSSIBILITY OF SUCH DAMAGES.

Table of Contents

List of Figures	iv
List of Tables	viii
General Safety Summary	xi
Service Safety Summary	xiii
Preface	xv
Manual Structure	xv
Manual Conventions	xvi
Finding Other Information	xvi
Contacting Tektronix	xvii
Introduction	xix
Performance Verification Procedures	xix
Strategy for Servicing	xix
Tektronix Service Offerings	xx

Specifications

Product Description	1-1
Models	1-1
Key Features	1-1
Mainframe and Output Module Configuration	1-3
Product Software	1-3
Software Upgrade	1-4
Specifications	1-5
Electrical Specification	1-6
Miscellaneous	1-35

Operating Basics

Installation	2-1
Supplying Operating Power	2-2
Checking the Environment Requirements	2-4
Output Module	2-5
Powering On the Data Timing Generator	2-6
Setting up Windows 2000	2-7
Shutting Down the Data Timing Generator	2-8
Creating an Emergency Rescue Disk	2-10
Backing Up User Files	2-12
Installing Software	2-12
Operating Basics	2-13
Front Panel Controls	2-13
Front Panel Connectors	2-17
Rear Panel Connectors	2-19
Peripherals on the Rear Panel	2-23
Display Area and Application Windows	2-24
Using the Menu System	2-51

Theory of Operation

Theory of Operation	3-1
Interconnect Diagrams	3-1
Block Diagrams	3-6

Performance Verification

Performance Verification	4-1
Conventions in this manual	4-1
Self Tests	4-3
Performance Tests	4-10
Mainframe	4-15
Output Module	4-62

Adjustment Procedures

Adjustment Procedures	5-1
------------------------------------	------------

Maintenance

Maintenance	6-1
Related Maintenance Procedures	6-1
Preparation	6-2
Inspection and Cleaning	6-4
Removal and Installation Procedures	6-9
Preparation for Use	6-9
Access Procedure	6-15
Procedures for External Modules	6-16
Procedures for Internal Modules (Lower)	6-31
Procedures for Internal Modules (Upper)	6-38
Troubleshooting	6-45
Troubleshooting tree	6-45
Diagnostics	6-53
System Recovery	6-69
Requirements for System Recovery	6-69
Operating Procedure	6-69
Service Password	6-73
Set up into the Service mode	6-73
Serial number registration	6-73

Replaceable Electrical Parts

Electrical Parts List	7-1
------------------------------------	------------

Diagrams

Diagrams	8-1
-----------------------	------------

Replaceable Mechanical Parts

Replaceable Mechanical Parts	9-1
---	------------

Parts Ordering Information	9-1
Using the Replaceable Parts List	9-2

List of Figures

Figure 1-1: DC Output channel assignment	1-8
Figure 1-2: Frequency response of clock output	1-10
Figure 1-3: Signal timing	1-15
Figure 1-4: DTG5078 Master-Slave connection	1-16
Figure 1-5: DTG5274 Master-Slave connection	1-17
Figure 1-6: Channel addition function	1-24
Figure 1-7: The definitions of Lead/Trail Delay and Pulse Width ..	1-25
Figure 1-8: Maximum Lead Delay	1-25
Figure 1-9: Output voltage window and clock out (DTGM30)	1-33
Figure 1-10: Equivalent circuit of DTGM10 and DTGM20 outputs	1-34
Figure 1-11: Equivalent circuit of DTGM30 output	1-34
Figure 2-1: Principal power switch and AC power connector	2-6
Figure 2-2: On/Standby switch location	2-6
Figure 2-3: Front panel controls	2-14
Figure 2-4: Front panel connectors	2-17
Figure 2-5: Rear panel connectors	2-19
Figure 2-6: Locations of peripheral connectors on rear panel	2-23
Figure 2-7: Screen elements just after the power on	2-24
Figure 2-8: Toolbar	2-29
Figure 2-9: Status bar	2-30
Figure 2-10: Channel Group window	2-31
Figure 2-11: Blocks window	2-32
Figure 2-12: Data-Listing window	2-34
Figure 2-13: Data-Waveform window	2-36
Figure 2-14: Level window	2-38
Figure 2-15: Timing window (Data Generator mode)	2-40
Figure 2-16: Time Base window	2-42
Figure 2-17: Sequence window	2-44
Figure 2-18: Subsequence window	2-46
Figure 2-19: Jitter Generation window	2-48
Figure 2-20: DC Output window	2-49
Figure 2-21: Menu selection	2-51
Figure 2-22: Window operation 1: Time Base window	2-52
Figure 2-23: Window operation 2: Timing window	2-53

Figure 2-24: Window operation 3: Data-Listing window	2-54
Figure 2-25: Window operation 4: Channel Group window	2-56
Figure 2-26: Window operation 5: Sequence window	2-57
Figure 3-1: DTG5078 interconnection diagram	3-4
Figure 3-2: DTG5274 interconnection diagram	3-5
Figure 3-3: DTG5078 block diagram	3-7
Figure 3-4: DTG5274 block diagram	3-8
Figure 4-1: Diagnostics dialog	4-4
Figure 4-2: Level Calibration dialog	4-6
Figure 4-3: Skew Calibration dialog	4-8
Figure 4-4: Skew Calibration results screen	4-9
Figure 4-5: Open Setup dialog	4-13
Figure 4-6: Sync output tests	4-16
Figure 4-7: Internal Clock Frequency tests	4-18
Figure 4-8: External Clock Output tests	4-20
Figure 4-9: External Clock Input tests	4-23
Figure 4-10: 10 MHz Reference Input tests	4-25
Figure 4-11: 10 MHz Reference Output tests	4-27
Figure 4-12: Phase Lock Input tests	4-28
Figure 4-13: Internal Trigger tests	4-30
Figure 4-14: Event Input and Sequence tests	4-34
Figure 4-15: Data pattern example	4-36
Figure 4-16: Jitter Generation tests	4-38
Figure 4-17: Jitter Generation example (all)	4-39
Figure 4-18: Jitter Generation example (partial)	4-41
Figure 4-19: DC Output tests	4-42
Figure 4-20: Delay timing tests	4-44
Figure 4-21: Clock out random jitter tests	4-48
Figure 4-22: Clock out random jitter sample	4-49
Figure 4-23: Random jitter tests	4-50
Figure 4-24: Random jitter waveform sample	4-52
Figure 4-25: Total jitter waveform sample	4-54
Figure 4-26: PG Mode tests	4-55
Figure 4-27: Master-Slave operation tests	4-58
Figure 4-28: DTG5000 Configuration Utility dialog	4-59
Figure 4-29: Master-Slave operation waveform sample	4-60
Figure 4-30: Data output DC level tests	4-63

Figure 4-31: Data format tests	4-67
Figure 4-32: Pulse pattern example	4-68
Figure 4-33: RZ waveform example	4-69
Figure 4-34: R1 waveform example	4-69
Figure 6-1: Instrument orientation (DTG5078)	6-11
Figure 6-2: External modules	6-12
Figure 6-3: Front Panel assembly & Display assembly	6-13
Figure 6-4: Internal modules (Lower)	6-14
Figure 6-5: Internal modules (Upper)	6-14
Figure 6-6: Output Module removal	6-17
Figure 6-7: Modules on the rear panel	6-18
Figure 6-8: Loose the screws	6-18
Figure 6-9: CD-ROM module removal	6-19
Figure 6-10: Loose the screws	6-19
Figure 6-11: Loose the screws	6-20
Figure 6-12: Cabinet removal	6-21
Figure 6-13: Remove the screws	6-22
Figure 6-14: Front Panel assembly removal	6-23
Figure 6-15: Front Panel assembly removal	6-24
Figure 6-16: FD drive removal	6-24
Figure 6-17: Front panel chassis removal	6-25
Figure 6-18: A20 Front Key & DC Output board removal	6-26
Figure 6-19: A22 Power Switch Board removal	6-27
Figure 6-20: Display assembly removal	6-28
Figure 6-21: Inverter board removal	6-29
Figure 6-22: Fan removal	6-30
Figure 6-23: Support bracket removal	6-32
Figure 6-24: Unplug the cables and connectors	6-33
Figure 6-25: Unplug the cables and connectors	6-35
Figure 6-26: Unplug the cables and connectors	6-37
Figure 6-27: Power supply removal	6-39
Figure 6-28: A10 Connector & PCI Interface board removal	6-40
Figure 6-29: A10 Connector & PCI Interface board removal	6-41
Figure 6-30: Compact PCI Frame removal	6-42
Figure 6-31: A30 Compact PCI Backplane removal	6-43
Figure 6-32: Primary troubleshooting procedure (1)	6-46
Figure 6-33: Primary troubleshooting procedure (2)	6-47
Figure 6-34: Primary troubleshooting procedure (3)	6-48

Figure 6-35: Troubleshooting procedure B — Display section	6-48
Figure 6-36: Troubleshooting procedure A - Power Supply and A10 board section	6-49
Figure 6-37: Test point on the A10 Connector board	6-50
Figure 6-38: Diagnostics dialog box	6-54
Figure 6-39: Diagnostics error code format	6-58
Figure 6-40: Service Password dialog box	6-73
Figure 6-41: Set Serial Number dialog box	6-74
Figure 9-1: Main Chassis (1) (DTG5078)	9-5
Figure 9-2: Main Chassis (1) (DTG5274)	9-7
Figure 9-3: Main Chassis (2)	9-10
Figure 9-4: Main Chassis & Cabinet	9-11
Figure 9-5: A30 & Compact PCI Frame	9-13
Figure 9-6: Power Supply	9-15
Figure 9-7: Floppy Disk Drive	9-16
Figure 9-8: A10 Connector & PCI Interface	9-17
Figure 9-9: A32 CDROM Extender	9-19
Figure 9-10: Front Panel (DTG5078)	9-21
Figure 9-11: Front Panel (DTG5274)	9-23
Figure 9-12: Cabinet	9-25
Figure 9-13: Plug-In Box (DTG5078)	9-27
Figure 9-14: Plug-In Box (DTG5274)	9-29
Figure 9-15: Blank Plug-In	9-31
Figure 9-16: DTGM10	9-33
Figure 9-17: DTGM20	9-35
Figure 9-18: DTGM30	9-37
Figure 9-19: Op 1R (Rack Mount)	9-38

List of Tables

Table 1-1: DTG5000 series key features	1-2
Table 1-2: Operation mode	1-6
Table 1-3: Sequencer	1-6
Table 1-4: Clock Generator	1-7
Table 1-5: Internal Trigger Generator	1-7
Table 1-6: DC Output	1-7
Table 1-7: Clock Out	1-8
Table 1-8: External Clock In	1-10
Table 1-9: 10 MHz Reference In	1-11
Table 1-10: 10 MHz Reference Out	1-11
Table 1-11: Phase Lock In	1-11
Table 1-12: Skew Cal In	1-12
Table 1-13: Trigger In	1-12
Table 1-14: Sync Out	1-13
Table 1-15: Sync Clock In	1-13
Table 1-16: Sync Clock Out 1, Out 2 and Out 3	1-13
Table 1-17: Sync Jump In	1-14
Table 1-18: Sync Jump Out 1, Out 2 and Out 3	1-14
Table 1-19: Event In	1-17
Table 1-20: CPU module and peripheral devices	1-18
Table 1-21: Display	1-19
Table 1-22: DG Mode	1-19
Table 1-23: Clock Range in NRZ	1-23
Table 1-24: Clock Range in RZ/R1	1-24
Table 1-25: Delay Offset	1-24
Table 1-26: Lead Delay	1-26
Table 1-27: Trail Delay	1-26
Table 1-28: Jitter Amplitude	1-27
Table 1-29: PG Mode	1-28
Table 1-30: DTGM10	1-30
Table 1-31: DTGM20	1-31
Table 1-32: DTGM30	1-32
Table 1-33: Mechanical	1-35
Table 1-34: Installation requirement	1-36
Table 1-35: Environmental	1-36

Table 1-36: Power Supply	1-37
Table 1-37: Certifications and compliances	1-38
Table 1-38: Installation category and Pollution degree	1-39
Table 2-1: Power-cord conductor identification	2-2
Table 2-2: Power cord identification	2-3
Table 2-3: Operating requirements	2-4
Table 2-4: Additional connection information	2-23
Table 2-5: Control box menus	2-24
Table 2-6: File menus	2-25
Table 2-7: View menus	2-25
Table 2-8: Settings menus	2-27
Table 2-9: System menus	2-27
Table 2-10: Options menu	2-28
Table 2-11: Help menus	2-28
Table 2-12: Status Bar	2-30
Table 2-13: Edit menus for Channel Group window	2-31
Table 2-14: Setup items for Blocks window	2-33
Table 2-15: Edit menus for Blocks window	2-33
Table 2-16: Edit menus for Data-Listing window	2-35
Table 2-17: Edit menus for Data-Waveform window	2-36
Table 2-18: Setup items for Level window	2-38
Table 2-19: Edit menus for Level window	2-39
Table 2-20: Setup items for Timing window	2-40
Table 2-21: Edit menus for Timing window	2-41
Table 2-22: Setup items for Time Base window	2-42
Table 2-23: Setup items for Sequence window	2-44
Table 2-24: Edit menus for Sequence window	2-45
Table 2-25: Setup items for Subsequence window	2-46
Table 2-26: Edit menus for Subsequence window	2-47
Table 2-27: Setup items for Jitter Generation window	2-48
Table 2-28: Setup items for DC Output window	2-49
Table 2-29: Edit menus for DC output window	2-50
Table 2-30: Key operations	2-61
Table 4-1: Performance test items	4-10
Table 4-2: Test equipment	4-11
Table 4-3: Performance check files	4-14
Table 4-4: DTGM10 High Level Voltage Accuracy	4-64

Table 4-5: DTGM10 Low Level Voltage Accuracy	4-64
Table 4-6: DTGM20 High Level Voltage Accuracy	4-64
Table 4-7: DTGM20 Low Level Voltage Accuracy	4-65
Table 4-8: DTGM30 High Level Voltage Accuracy	4-66
Table 4-9: DTGM30 Low Level Voltage Accuracy	4-66
Table 6-1: Relative susceptibility to static-discharge damage	6-3
Table 6-2: External inspection check list	6-5
Table 6-3: Internal inspection check list	6-6
Table 6-4: Tools required for module removal	6-10
Table 6-5: Performance Test	6-51
Table 6-6: Diagnostics dialog box buttons	6-54
Table 6-7: Information on Status	6-57
Table 6-8: Category of the Diagnostics Error Code	6-59
Table 6-9: Error Codes	6-60

General Safety Summary

Review the following safety precautions to avoid injury and prevent damage to this product or any products connected to it. To avoid potential hazards, use this product only as specified.

Only qualified personnel should perform service procedures.

To Avoid Fire or Personal Injury

Use Proper Power Cord. Use only the power cord specified for this product and certified for the country of use.

Ground the Product. This product is grounded through the grounding conductor of the power cord. To avoid electric shock, the grounding conductor must be connected to earth ground. Before making connections to the input or output terminals of the product, ensure that the product is properly grounded.

Observe All Terminal Ratings. To avoid fire or shock hazard, observe all ratings and markings on the product. Consult the product manual for further ratings information before making connections to the product.

The common terminal is at ground potential. Do not connect the common terminal to elevated voltages.

Do not apply a potential to any terminal, including the common terminal, that exceeds the maximum rating of that terminal.

Do Not Operate Without Covers. Do not operate this product with covers or panels removed.

Avoid Exposed Circuitry. Do not touch exposed connections and components when power is present.

Do Not Operate With Suspected Failures. If you suspect there is damage to this product, have it inspected by qualified service personnel.

Do Not Operate in Wet/Damp Conditions.

Do Not Operate in an Explosive Atmosphere.

Keep Product Surfaces Clean and Dry.

Provide Proper Ventilation. Refer to the manual's installation instructions for details on installing the product so it has proper ventilation.

Symbols and Terms

Terms in this Manual. These terms may appear in this manual:



WARNING. *Warning statements identify conditions or practices that could result in injury or loss of life.*



CAUTION. *Caution statements identify conditions or practices that could result in damage to this product or other property.*

Terms on the Product. These terms may appear on the product:

DANGER indicates an injury hazard immediately accessible as you read the marking.

WARNING indicates an injury hazard not immediately accessible as you read the marking.

CAUTION indicates a hazard to property including the product.

Symbols on the Product. The following symbols may appear on the product:



WARNING
High Voltage



Protective Ground
(Earth) Terminal



CAUTION
Refer to Manual



Double
Insulated

Service Safety Summary

DTG5000 Series Only qualified personnel should perform service procedures. Read this *Service Safety Summary* and the *General Safety Summary* before performing any service procedures.

Do Not Service Alone. Do not perform internal service or adjustments of this product unless another person capable of rendering first aid and resuscitation is present.

Disconnect Power. To avoid electric shock, disconnect the mains power by means of the power cord or, if provided, the power switch.

Use Care When Servicing With Power On. Dangerous voltages or currents may exist in this product. Disconnect power, remove battery (if applicable), and disconnect test leads before removing protective panels, soldering, or replacing components.

To avoid electric shock, do not touch exposed connections.

Calendar (date and time) Backup Battery. This product contains a Lithium:poly-carbon monofluoride battery for calendar backup purposes. This battery is part of the CPU unit and is not replaceable.

Preface

This manual provides information necessary for service technicians to service the DTG5000 Series Data Timing Generator to the module level.

Manual Structure

This manual is divided into sections, such as *Specifications* and *Theory of Operation*. Further, some sections are divided into subsections, such as *Product Description* and *Removal and Installation Procedures*.

Sections containing procedures also contain introductions to those procedures. Be sure to read these introductions because they provide information needed to do the service correctly and efficiently. The following contains a brief description of each manual section.

- *Specifications* contains a description of the data timing generator and the characteristics that apply to it.
- *Operating Information* includes general information and operating instructions.
- *Theory of Operation* contains circuit descriptions that support service to the module level.
- *Performance Verification* contains procedures for confirming that the data timing generator functions properly and meets warranted limits.
- *Adjustment Procedures* contains information that you need to manually adjust the data timing generator so that it meets specifications.
- *Maintenance* contains information and procedures for performing preventive and corrective maintenance of the data timing generator. These instructions include cleaning, module removal and installation, and fault isolation to the module.
- *Replaceable Electrical Parts* contains a statement referring you to *Replaceable Mechanical Parts*, where both electrical and mechanical modules are listed.
- *Diagrams* contains block diagrams and an interconnection diagram.
- *Replaceable Mechanical Parts* includes a table of all replaceable modules, their descriptions, and their Tektronix part numbers.

Manual Conventions

This manual uses certain conventions that you should become familiar with.

Some sections of the manual contain procedures for you to perform. To keep those instructions clear and consistent, this manual uses the following conventions:

- Name of front panel controls and menus appears in the same case (initial capitals, all uppercase, and so on) in the manual as is used on the data timing generator front-panel and menus. Front -panel names are all upper case letters (for example, MENU, SELECT, PULSE GEN, and so on).
- Instruction steps are numbered unless there is only one step.

Modules Throughout this manual, any replaceable component, assembly, or part of the data timing generator is referred to generically as a module. In general, a module is an assembly (like a circuit board), rather than a component (like a resistor or an integrated circuit). Sometimes a single component is a module; for example, the chassis of the data timing generator is a module.

Safety Symbols and terms related to safety appear in the *Safety Summary* near the beginning of this manual.

Finding Other Information

This manual mainly focuses on the performance verification, troubleshooting and maintenance of the data timing generator. See the following list for other documents supporting the data timing generator operation.

Document name	Description
<i>DTG5000 Series Online Help</i>	An online help system, integrated with the User Interface application that ships with this product. The help is preinstalled in the instrument.
<i>DTG5000 Series User Manual, volume 1</i>	A quick reference to major features of the instrument and how they operate. It also provides several tutorials to familiarize the user with basic instrument features.
<i>DTG5000 Series User Manual, volume 2</i>	A comprehensive usage information on how to operate the instrument including the descriptions of functions and menu operations.
<i>DTG5000 Series Programmer Manual</i>	Provides complete information on programming commands and remote control of the instrument.

Contacting Tektronix

Phone	1-800-833-9200*
Address	Tektronix, Inc. Department or name (if known) 14200 SW Karl Braun Drive P.O. Box 500 Beaverton, OR 97077 USA
Web site	www.tektronix.com
Sales support	1-800-833-9200, select option 1*
Service support	1-800-833-9200, select option 2*
Technical support	Email: techsupport@tektronix.com 1-800-833-9200, select option 3* 6:00 a.m. – 5:00 p.m. Pacific time

* **This phone number is toll free in North America. After office hours, please leave a voice mail message.
Outside North America, contact a Tektronix sales office or distributor; see the Tektronix web site for a list of offices.**

Introduction

This manual contains information that is needed to properly service the DTG5000 Series Data Timing Generator as well as general information that is critical to safe and effective servicing.

To prevent personal injury or damage to the data timing generator, consider the following before attempting service:

- The procedures in this manual should be performed only by a qualified service person.
- Read the *General Safety Summary* on page xi and the *Service Safety Summary*, beginning on page xiii.
- Read *Installation* in *Operating Information*.

When using this manual for servicing, be sure to follow all warnings, cautions, and notes.

Performance Verification Procedures

The performance check described in the *Performance Verification* section should be done every 12 months. In addition, a performance check is recommended after module replacement.

If the data timing generator does not meet performance criteria, repair is necessary.

Strategy for Servicing

Throughout this manual, the term, *module*, refers to any field-replaceable component, assembly, or part of the data timing generator.

This manual contains all the information needed for periodic maintenance of the data timing generator. Further, it contains all information for corrective maintenance down to the module level. To isolate a failure to a module, use the troubleshooting procedures found in the *Maintenance* section. To remove and replace any failed module, follow the instructions in the *Removal and Installation Procedures* subsection. After isolating a faulty module, replace it with a fully-tested module obtained from the factory. The *Replaceable Mechanical Parts* section contains part number and ordering information for all replaceable modules.

Tektronix Service Offerings

Tektronix provides service to cover repair under warranty as well as other services that may provide a cost-effective answer to your service needs.

Whether providing warranty repair service or any of the other services listed below, Tektronix service technicians are well trained to service the data timing generator. They have access to the latest information on improvements to the DTG5000 Series as well as new options.

Warranty Repair Service

Tektronix warrants this product for one year from date of purchase. The warranty appears at the front of this manual. Tektronix technicians provide warranty service at most Tektronix service locations. The Tektronix product catalog lists all worldwide service locations.

Self Service

Tektronix supports repair to the module level by providing Module Exchange.

Module Exchange. This service reduces down-time for repair by allowing you to exchange most modules for remanufactured ones. Each module comes with a 90-day service warranty.

For More Information. Contact your local Tektronix service center or sales engineer for more information on any of the repair or adjustment services just described.



Specifications

Product Description

This section describes the DTG5000 Series Data Timing Generators and their options. Following this description are two subsections:

- *Installation* shows you how to configure and install the data timing generator, as well as how to reinstall the system software included with the product.
- *Accessories & Options* lists the standard and optional accessories for this product.

Models

This manual supports the following data timing generators:

- DTG5078 Data Timing Generator
- DTG5274 Data Timing Generator

The differences between the data timing generators will be called out when necessary; otherwise, the material applies to all data timing generators. The word “data timing generator” and “DTG5000 Series” refer to both products.

Key Features

The DTG5000 Series Data Timing Generator is a high speed/multichannel signal generator which creates a wide range of digital timing signals. The products are designed to generate a data pattern for standard and nonstandard pulses necessary for functional tests or characterization of legacy devices (TTL, CMOS, ECL) as well as the latest devices (PECL, LVDS, GTL, CML).

The DTG5000 Series Data Timing Generator supports three types of output modules (DTGM10, DTGM20, and DTGM30). Table 1-1 lists the key features of the data timing generators.

Table 1-1: DTG5000 series key features

	DTG5078			DTG5274		
Maximum clock frequency/ Maximum data rate	750 MHz/750 Mb/s			2.7GHz /2.7 Gb/s		
Number of slots	8 (A, B, C, D, E, F, G, and H)			4 (A, B, C, and D)		
Pattern length	240 to 8,000,000 words/channel			960 to 32,000,000 words/channel		
Block size granularity	1			1 to 4 (depends on Vector Rate)		
Sequence steps	1 to 8,000 steps			1 to 8,000 steps		
Sequence repeat counter	1 to 65,536 or Infinite			1 to 65,536 or Infinite		
Data Generator Mode	Slot A, B, C, D, E, F, G, and H			Slot A, B, C, and D		
Data format	Slot A to D	NRZ, RZ, and R1		Slot A to D	NRZ, RZ, and R1	
	Slot E to H	NRZ				
Data rate	NRZ	50 kb/s to 750 Mb/s		NRZ	50 kb/s to 2.7 Gb/s	
	RZ and R1	50 kb/s to 375 Mb/s			RZ and R1	50 kb/s to 1.35 Gb/s
Channel addition	Slot A, B, C, and D			Slot A, B, C, and D		
Jitter generation	Channel 1 of slot A			Channel 1 of slot A		
Lead delay resolution	1 ps			0.2 ps		
Trail delay resolution	5 ps			5 ps		
Pulse width resolution	5 ps (slot A, B, C, and D)			5 ps (slot A, B, C, and D)		
Pulse Generator Mode	Slot A, B, C, and D			Slot A, B, C, and D		
Clock frequency	50 kHz to 375 MHz			50 kHz to 1.35 GHz		
Output Module	DTGM10	DTGM20	DTGM30	DTGM10	DTGM20	DTGM30
Number of channel	4	4	2	2 of 4 (CH1, CH2)	2 of 4 (CH1, CH2)	2
Amplitude (50 Ω)	3.5 V _{p-p} ¹	3.5 V _{p-p}	1.25 V _{p-p}	3.5 V _{p-p} ¹	3.5 V _{p-p}	1.25 V _{p-p}
Amplitude (1 MΩ)	10 V _{p-p}	7 V _{p-p}	2.5 V _{p-p}	10 V _{p-p}	7 V _{p-p}	2.5 V _{p-p}
Rise time/fall time at 1 V _{p-p} into 50 Ω (20% to 80%)	< 540 ps (variable)	< 340 ps (variable)	< 110 ps	< 540 ps (variable)	< 340 ps (variable)	< 110 ps
Master-Slave	Up to three (one Master, two Slaves)			Up to two (one Master, one Slave)		

¹ This value is limited by the maximum output current (+/- 40 mA, maximum).

Mainframe and Output Module Configuration

The DTG5000 Series Data Timing Generator offers card modular system. Three types of the output modules can be combined in any combination. Each module can be inserted into any slot. The functional restrictions are:

- 8 (eight) slots installed in the DTG5078 (A, B, C, D, E, F, G, and H)
- 4 (four) slots installed in the DTG5274 (A, B, C, and D)
- When the DTGM10 or DTGM20 is installed to the DTG5274, CH3 and CH4 are not available. Only CH1 and CH2 can be used.
- Slot E, F, G, and H are not available in the Pulse Generator mode.
- Available data formats are different:
 - NRZ, RZ, R1 (Slot A, B, C, and D)
 - NRZ (Slot E, F, G, and H)

Product Software

The data timing generator includes the following software:

- The system software, which includes a specially configured version of Windows 2000, comes preinstalled on the data timing generator. Windows 2000 is the operating system on which the user-interface application of this product runs, and provides an open desktop for you to install other compatible applications.

NOTE. Do not attempt to substitute any version of Windows that is not specifically provided by Tektronix for use with this instrument.

- The DTG5000 Software comes preinstalled on the data timing generator. This software runs on Windows 2000 Operating System is the data timing generator application. This software starts automatically when the data timing generator is powered on, and provides the user interface (UI) and all other instrument control functions. You can also minimize the data timing generator application.
 - The product software runs not only on the data timing generator mainframe, but also on the general PC. When the software runs on the data timing generator mainframe, it is called *Online mode*. When it runs on the PC, it is called *Offline mode*. In the Offline mode, it is possible to create and edit the pattern data and set the output parameters.

- The DTG5000 Configuration Utility comes preinstalled on the data timing generator. This software, which runs on a Windows 2000 Operating System, is used for setting up the system configurations for the DTG5000 Software. This software controls the Master operation, Master-Slave operation, Online/Offline operation, and so forth.

NOTE. When you use the DTG5000 software with the offline mode, you must also install the DTG5000 Configuration Utility on your PC.

- The Readme file contains release notes and updates that could not be included in other product documentation.
- There are no limits on number of PCs that can operate in the offline mode.

Occasionally new versions of software for your instrument may become available at our web site. See *Contacting Tektronix* on page xvii in the *Preface* section for web site information.

Software Upgrade

Tektronix may offer software upgrade kits for the data timing generator. Contact your Tektronix service representative for more information (see *Contacting Tektronix* on page xvii).

Specifications

This section contains the DTG5000 Series Data Timing Generator specifications. All specifications are guaranteed unless labeled “typical”. Typical specifications are provided for your convenience but are not guaranteed.

Specifications that are check marked with the ✓ symbol are checked directly (or indirectly) in the *Performance Verification* chapter of this manual.

Performance Conditions

The performance limits in this specification are valid with these conditions:

- The instrument must have been calibrated/adjusted at an ambient temperature between +20° C and +30° C.
- The instrument must be in an environment with temperature, altitude, humidity, and vibration within the operating limits described in these specifications.
- The instrument must have had a warm-up period of at least 20 minutes.
- The instrument must be operating at an ambient temperature between +10° C and +40° C.

Electrical Specification

Mainframe

Table 1-2: Operation mode

Characteristics	Description
Data Generator Mode (DG Mode)	Operates as a data generator. The output data is created by a built-in pattern editor, or by importing files that have created by external simulation software tools. The output timing is defined by sample clock rate. <ul style="list-style-type: none"> - Timing control: Delay, Slew rate, Width - Level control: High/Low or Amplitude/Offset - Supports flexible block branching sequence function. <p><i>Note: Jump is not available if Long Delay is set to On.</i></p>
Pulse Generator Mode (PG Mode)	Operates as a pulse generator. The output timing is defined by signal output frequency. <ul style="list-style-type: none"> - Timing control: Pulse width, Delay, Duty, Slew rate - Level control: High/Low or Amplitude/Offset

Table 1-3: Sequencer

Characteristics	Description
Pattern Length	
DTG5078	
Hardware Sequence	240 to 8,000,000 words
Software Sequence	1 to 8,000,000 words
DTG5274	
Hardware Sequence	960 to 32,000,000 words
Software Sequence	1 to 32,000,000 words
Pattern Length Granularity	
DTG5078	
Hardware Sequence	1 word
Software Sequence	1 word
DTG5274	
Hardware Sequence	Depends on vector rate. Refer to Table 1-23 and Table 1-24.
Software Sequence	1 word
Sequence Length	1 to 8000 steps
Maximum Blocks	8000
Maximum sub-sequences	50
Sub-sequence Length	1 to 256 steps
Sequence Repeat Counter	1 to 65,536 or Infinite, All channels operate the same sequence.

Table 1-4: Clock Generator

Characteristics	Description	PV reference page
Clock Frequency		
DTG5078	50 kHz to 750 MHz	
DTG5274	50 kHz to 3.35 GHz	
Resolution	8 digits	
Internal clock ²		
✓ Accuracy	within ± 1 ppm	Page 4-18

² The internal reference oscillator is used.

Table 1-5: Internal Trigger Generator

Characteristics	Description
Internal trigger rate ³	
Range	1.0 μ s to 10.0 s
Resolution	3 digits, minimum 0.1 μ s

³ The internal reference oscillator is used.

Table 1-6: DC Output

Characteristics	Description	PV reference page
Connector	2.54 mm 2 x 8 pin header (female), front right side	
Number of Channel	8	
Source Resistance	approximately 1 Ω	
Level		
Voltage Range	-3.0 V to 5.0 V	
Control	Independent	
Resolution	10 mV	
✓DC Accuracy	($\pm 3\%$ of the set value) ± 50 mV	Page 4-42
Maximum Output Current	± 30 mA	
Pin Assignment	Refer to Figure 1-1.	

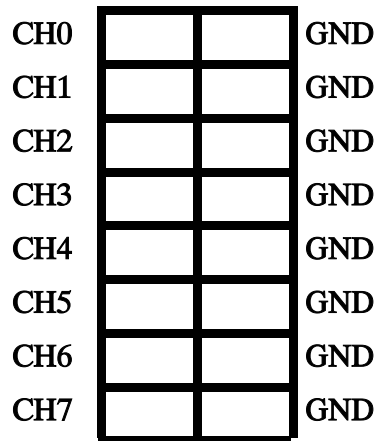

Figure 1-1: DC Output channel assignment

Table 1-7: Clock Out

Characteristics	Description	PV reference page
Output connector	SMA rear	
Output Signal Type	Complementary	
Frequency		
DTG5078	50 kHz to 750 MHz	
DTG5274	50 kHz to 3.35 GHz	
Impedance	50 Ω	
Output Voltage Level ⁴		
Range		
High Level (VOH) ⁵	- 1.00 V to 2.47 V into 50 Ω to GND - 1.94 V to 7.00 V into 1 M Ω to GND	
Low Level (VOL) ⁶	- 2.00 V to 2.44 V into 50 Ω to GND - 2.00 V to 6.94 V into 1 M Ω to GND	
Output Voltage Amplitude ⁷		
Range	30 mV _{p-p} to 1.25V _{p-p} into 50 Ω to GND 60 mV _{p-p} to 2.5V _{p-p} into 1 M Ω to GND	
Resolution	10 mV	
Output Voltage Frequency Response	\pm 10 dB of value shown in the curve of Figure 1-2.	

Table 1-7: Clock Out (cont.)

Characteristics	Description	PV reference page
Output Voltage Offset		
Resolution	40 mV	
Range	Depends on the limit of VOH and VOL set by the user. Refer to Output Voltage Level. Offset = (VOH + VOL) / 2	
Maximum Output Current	± 80 mA	
✓ Rise /Fall Time (20% to 80%), typical		
DTG5078		
at 100 mV _{p-p} amplitude, 0 V offset	< 85 ps into 50 Ω to GND	Page 4-20
at 1.00 V _{p-p} amplitude, 0 V offset	< 100 ps into 50 Ω to GND	
DTG5274		
at 100 mV _{p-p} amplitude, 0 V offset	< 70 ps into 50 Ω to GND	Page 4-20
at 1.00 V _{p-p} amplitude, 0 V offset	< 80 ps into 50 Ω to GND	
✓ Aberration, typical		
Positive Overshoot	< 10 % at 1V _{p-p} into 50 Ω	Page 4-20
Negative Overshoot	< 10 % at 1V _{p-p} into 50 Ω	
✓ Random Jitter, typical	Measured by RMS jitter in Measurement function of CSA8000 + 80E03.	
DTG5078	< 2 ps rms, at 750 Mb/s, amplitude = 0.8 V _{p-p}	Page 4-47
DTG5274	< 2 ps rms, at 2.7 Gb/s, amplitude = 0.8 V _{p-p}	

4 **VoH and VoL cannot be set directly. they are calculated by the DTG5000 as a function of the amplitude and offset level. There is no menu to set the VoH or VoL directly. Refer to Figure 1-11 on page 1-34.**

5 **High level (VoH) should fulfill the following formulas.**

$R_L = \text{Term R, } V_{tt} = \text{Term V}$

$$V_{OH} \leq 7.00$$

$$V_{OH} \leq (7.00 \times R_L + 50 \times V_{tt}) / (R_L + 50)$$

$$V_{OH} \leq R_L / 50 \times (2.5 - 0.06 \times R_L / (R_L + 50)) + V_{tt}$$

$$V_{OH} \geq (-2.00 \times R_L + 50 \times V_{tt}) / (R_L + 50)$$

$$V_{OH} \geq V_{tt} - R_L / 50$$

6 **Low level (VoL) should fulfill the following formulas.**

$R_L = \text{Term R, } V_{tt} = \text{Term V}$

$$V_{OL} \geq -2.00$$

$$V_{OL} \geq (50 \times V_{tt} - 4.5 \times R_L) / (R_L + 50)$$

$$V_{OL} \geq V_{tt} - R_L (0.02 + 2.5 / (R_L + 50))$$

$$V_{OL} < ((2.5 - 0.06) \times R_L / 50) + V_{tt}$$

Specifications

7 Amplitude should fulfill the following formulas. Amplitude = VOH - VOL

$R_L = \text{Term R, } V_{tt} = \text{Term V}$

$$VOH - VOL > 2 \times (V_{tt} - R_L/50 - \text{Offset})$$

$$VOH - VOL > 2 \times ((R_L \times (-2) + 50 \times V_{tt}) / (R_L + 50) - \text{Offset})$$

$$VOH - VOL < 2 \times ((2.5 \times R_L - 50 \times \text{Offset} + 50 \times V_{tt}) / (2 \times R_L + 50))$$

$$VOH - VOL < 2 \times ((7 \times R_L - 50 \times V_{tt}) / (R_L + 50) - \text{Offset})$$

(1) at 0.5 Vp-p Output Voltage Frequency Response (Amplitude : 0.50Vpp) of Clock Out

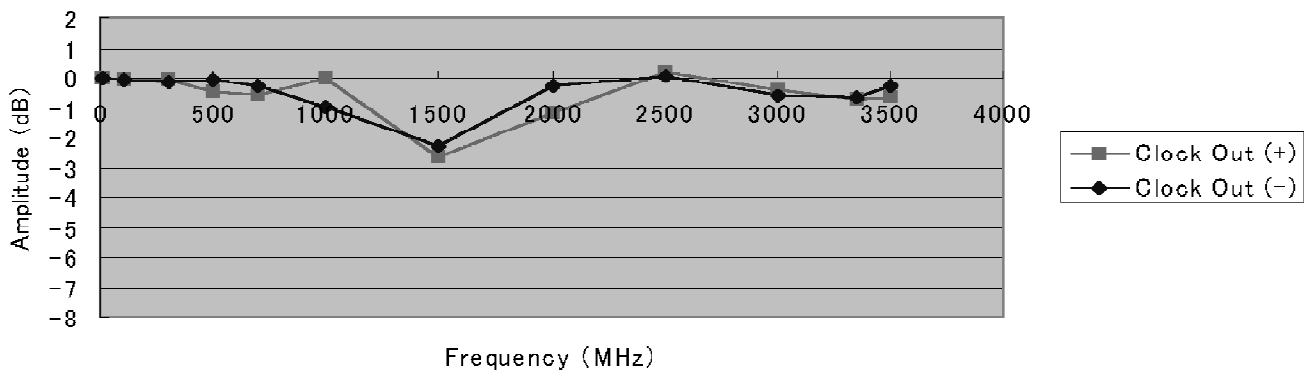

(2) at 1.0 Vp-p Clock Output Frequency Response (Amplitude : 1.00Vpp) of Clock Out

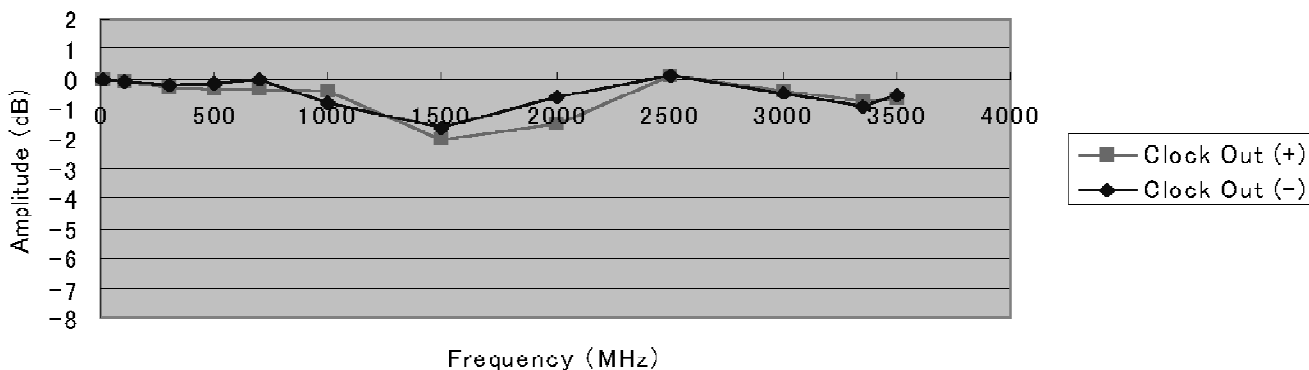

Figure 1-2: Frequency response of clock output

Table 1-8: External Clock In

Characteristics	Description
Connector	SMA rear
Impedance	50 Ω , AC coupled
Required Input Voltage Swing	400 mV _{p-p} to 2 V _{p-p} into 50 Ω
Required Duty Cycle	50 \pm 5%

Table 1-8: External Clock In (cont.)

Characteristics	Description
Frequency Range	Slew rate should be more than 10 mV/ns.
DTG5078	1 MHz to 750 MHz
DTG5274	1 MHz to 2.7 GHz

Table 1-9: 10 MHz Reference In

Characteristics	Description	PV reference page
Connector	BNC rear	
Impedance	50 Ω , AC coupled,	
Required Input Voltage Swing	200 mV _{p-p} to 3 V _{p-p}	
✓Frequency Range	10 MHz \pm 0.1 MHz	Page 4-25

Table 1-10: 10 MHz Reference Out

Characteristics	Description	PV reference page
Connector	BNC rear	
Impedance	50 Ω , AC coupled	
✓Amplitude, typical	1.2 V _{p-p} into 50 Ω to GND 2.4 V _{p-p} into 1 M Ω to GND	Page 4-26

Table 1-11: Phase Lock In

Characteristics	Description	PV reference page
Connector	BNC rear	
Impedance	50 Ω , AC coupled	
Required Input Voltage Swing	200 mV _{p-p} to 3 V _{p-p}	
✓Frequency Range	1 MHz to 200 MHz	Page 4-28
Multiplier Rate ⁸		
Long Delay, Off		
NRZ	x N, The maximum value of N is limited by the maximum data rate.	
RZ and R1	x N/2, The maximum value of N is limited by the maximum data rate.	
Long Delay, On	x N / (vector rate)	

⁸ N is an arbitrary integer.

Table 1-12: Skew Cal In

Characteristics	Description
Connector ⁹	SMA front
Input Signal Type	Single end
Level	ECL into 50 Ω to -2 V

⁹ This input is used only in calibrating a skew between channels. Refer to the reference manual for details.

Table 1-13: Trigger In

Characteristics	Description
Connector	BNC front
Impedance	1 k Ω or 50 Ω
Slope	Positive or Negative
Input Voltage Range	- 10 V to 10 V, 1k Ω selected - 5 V to 5 V, 50 Ω selected
Threshold	
Level	- 5.0 V to 5.0 V
Resolution	0.1 V
Required Minimum Input Swing	1.0 V _{p-p} , 1 k Ω selected 0.5 V _{p-p} , 50 Ω selected
Required Minimum Pulse Width (Pw1)	20 ns, refer to Figure 1-3.
Maximum Delay Time to Data Out (Td1)	Refer to Figure 1-3.
DTG5078	47 H/W Clocks + 5 VCO (Ext) Clocks + 50 ns
DTG5274	201 H/W Clocks + 5 VCO (Ext) Clocks + 50 ns
Trigger Holdoff Time (Td 3)	Refer to Figure 1-3.
DTG5078	29 H/W Clocks + 500 ns
DTG5274	115 H/W Clocks + 500 ns

Table 1-14: Sync Out

Characteristics	Description ¹⁰	PV reference page
Connector	SMA front	
Output Signal Type	Single end	
✓Level, typical	CML (Current Mode Logic)	
VOH	0 V into 50 Ω to GND	Page 4-15
VOL	-0.4 V into 50 Ω to GND	
Pulse Width (Pw 2)	Refer to Figure 1-3.	
DTG5078	4 Clocks	
DTG5274	4 Clocks	
Delay Time to Data Out (Td2), typical	- 4.5 ns, refer to Figure 1-3.	
Rise/Fall Time (20 to 80%)	< 140 ps	

¹⁰ **DG Mode: A positive pulse is generated at the beginning of each block.**
PG Mode: A positive pulse is generated on each trigger if the Run Mode is set to Burst.
Sync Out is not available if the Run Mode is set to Continuous.

Table 1-15: Sync Clock In

Characteristics	Description ¹¹
Connector	SMA rear
Output Signal Type	Complementary

¹¹ **This signal is used for only Master-Slave operation with another DTG5000 series instrument.**
Refer to the user manual vol.2 for details. The cable connection in Master-Slave operation in units is shown in Figure 1-4 and Figure 1-5.

Table 1-16: Sync Clock Out 1, Out 2 and Out 3

Characteristics	Description ¹²
Connector	SMA rear
Output Signal Type	Complementary

¹² **This signal is used for only Master-Slave operation with another DTG5000 series instrument.**
Refer to the user manual vol.2. for details. Sync Clock Out 3 is available only in DTG5078.
The cable connection in Master-Slave operation in units is shown in Figure 1-4 and Figure 1-5.

Table 1-17: Sync Jump In

Characteristics	Description ¹³
Connector	BNC rear

¹³ This signal is used for only Master-Slave operation with another DTG5000 series instrument. Refer to the user manual vol.2 for details. The cable connection in Master-Slave operation in units is shown in Figure 1-4 and Figure 1-5.

Table 1-18: Sync Jump Out 1, Out 2 and Out 3

Characteristics	Description ¹⁴
Connector	BNC rear

¹⁴ This signal is used for only Master-Slave operation with another DTG5000 series instrument. Refer to the user manual vol.2 for details. Sync Jump Out 3 is equipped only with DTG5078. The cable connection in Master-Slave operation in units is shown in Figure 1-4 and Figure 1-5.

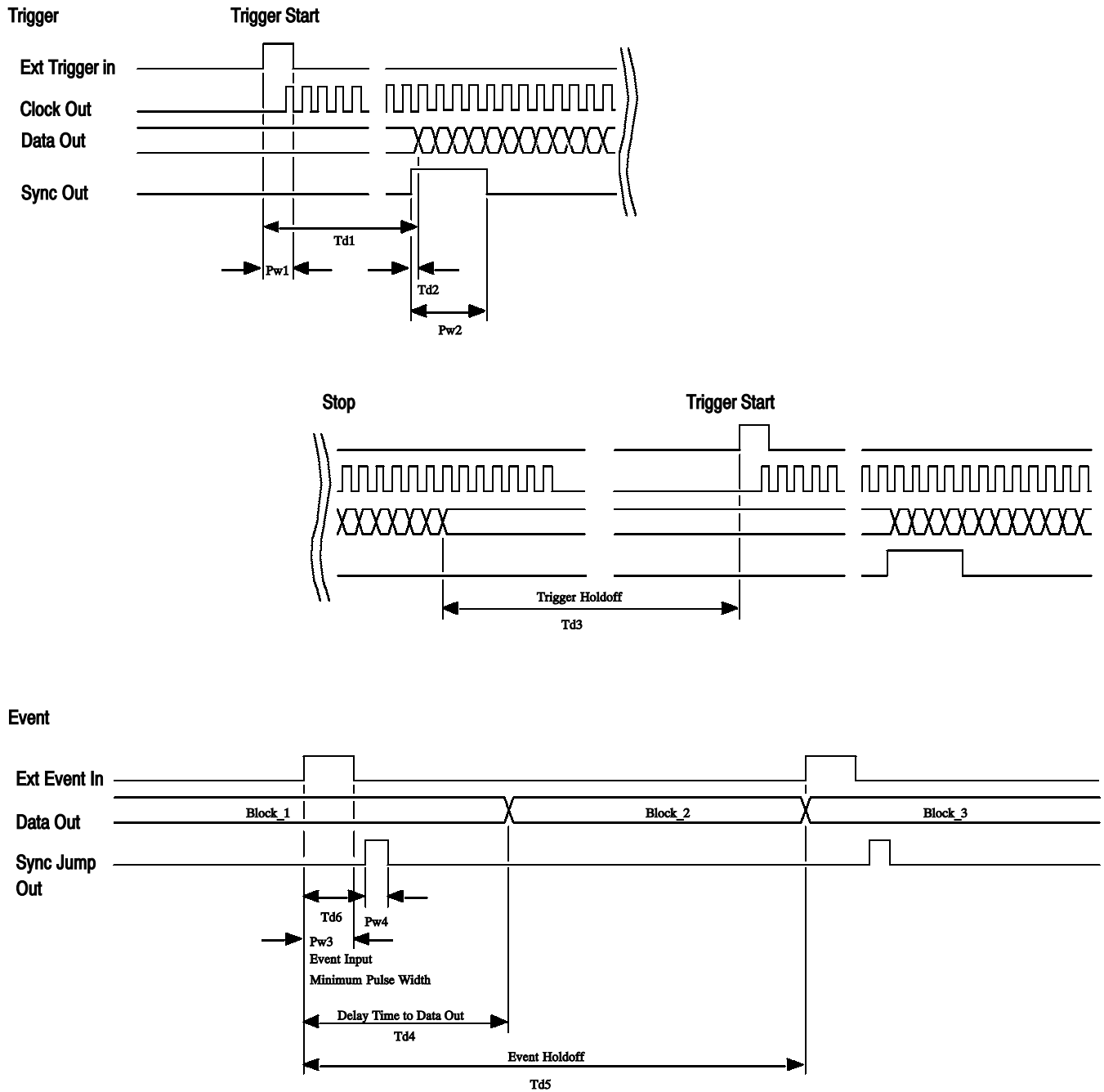

Figure 1-3: Signal timing

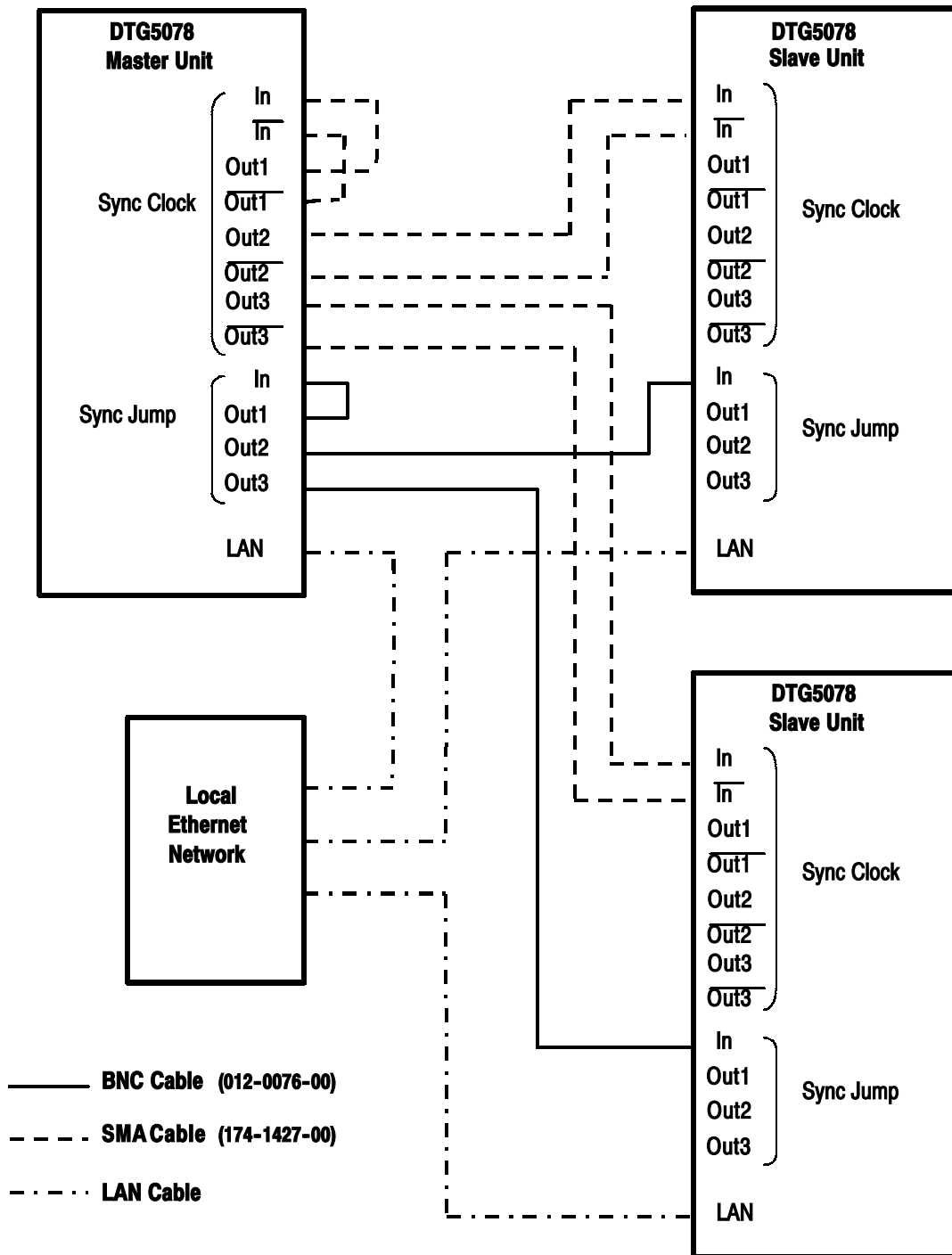

Figure 1-4: DTG5078 Master-Slave connection

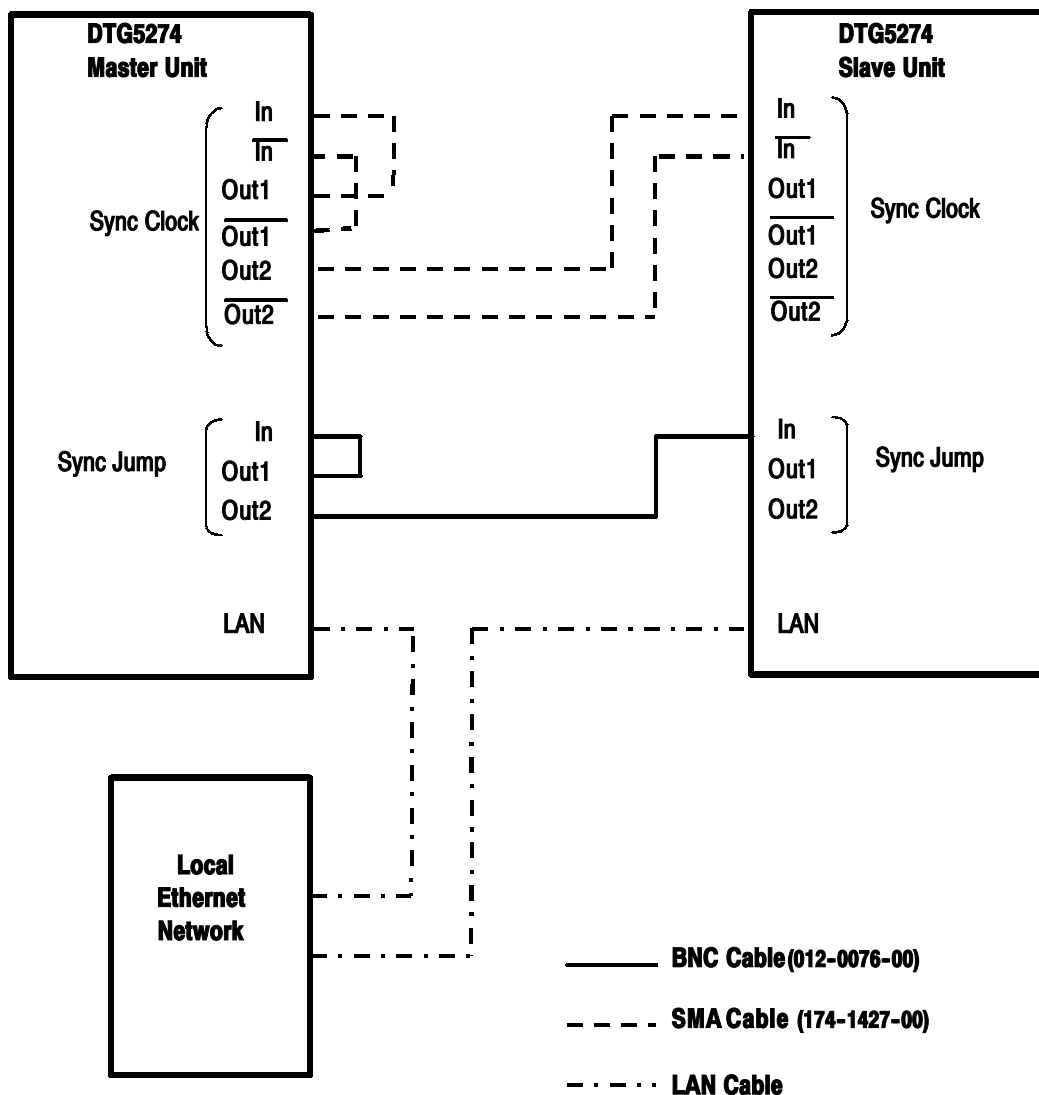

Figure 1-5: DTG5274 Master-Slave connection

Table 1-19: Event In

Characteristics	Description
Connector	BNC front
Impedance	1 k Ω or 50 Ω
Polarity	Normal or Invert
Input Voltage Range	- 10 V to 10 V, 1k Ω selected - 5 V to 5 V, 50 Ω selected

Specifications

Table 1-19: Event In (cont.)

Characteristics	Description
Threshold	
Level	- 5.0 V to 5.0 V
Resolution	0.1 V
Required Minimum Input Swing	1.0 V _{p-p} , 1 k Ω selected 0.5 V _{p-p} , 50 Ω selected
Required Minimum Pulse Width	
DTG5078	32 H/W Clocks + 10 ns
DTG5274	128 H/W Clocks + 10 ns
Maximum Delay Time to Data Output (Td4)	at Asynchronous Jump Mode, refer to Figure 1-3.
DTG5078	402 H/W Clocks
DTG5274	1621 H/W Clocks
Event Holdoff Time (Td5)	at Asynchronous Jump Mode, refer to Figure 1-3.
DTG5078	320 H/W Clocks
DTG5274	1280 H/W Clocks

Table 1-20: CPU module and peripheral devices

Characteristics	Description
CPU	Celeron 566 MHz
Core Chip	Intel 815E (815GMCH + ICH12)
DRAM	128 MB SDRAM
Storage	
Hard Disk	\geq 20 GB, User usable area is about 90 %
USB	USB 1.1 Series A 2ch Receptacle, rear Series A 1ch Receptacle, front right side
Ethernet	10BASE-T, 100BASE-TX, rear
Video Output	
Connector	15 pin Dsub, rear
Format	VGA (640 X 480), SVGA (800 X 600), XGA (1024 X 768), SXGA (1280 X 1024), UXGA (1600 X 1200)
GPIB	24 pin, IEEE488.2, rear
Drive	Floppy disk 1.44 MB, front CD-ROM, rear
Keyboard Connector	PS/2 type connector (6-pin mini-DIN), rear
Mouse Connector	PS/2 type connector (6-pin mini-DIN), rear

Table 1-20: CPU module and peripheral devices (cont.)

Characteristics	Description
Serial Port	RS232C, 9 pin Dsub, rear
Physical Specifications	Comply with IEEE1101.10 233.4 mm (W) x 160 mm (D) x 40 mm (H)
Real Time Clock	
Lifetime	>5 years
Type	Coin type lithium battery, CR2032 (Li 3 V 220 mAh)

Table 1-21: Display

Characteristics	Description
Display Area	Horizontal: 170.4 mm (6.71 in) Vertical: 127.8 mm (5.03 in)
Resolution	800 (H) × 600 (V) pixels (SVGA)

Output Pattern

Table 1-22: DG Mode

Characteristics	Description	PV reference page
Data Format		
Slot A to D	NRZ, RZ, R1	
Slot E to H	NRZ	
Data Rate		
DTG5078		
NRZ only	50 kb/s to 750 Mb/s	
with RZ/R1	50 kb/s to 375 Mb/s	
DTG5274		
NRZ only	50 kb/s to 2.7 Gb/s	
with RZ/R1	50 kb/s to 1.35 Gb/s	
Data Rate Resolution		
Internal Clock	8 digits	
External Clock	4 digits	
External Phase Lock In	4 digits	
Clock Range	Refer to Table 1-23 and Table 1-24.	

Table 1-22: DG Mode (cont.)

Characteristics	Description	PV reference page
Channel Addition	Slot E, F, G and H are not available in DTG5078. Refer to Figure 1-6 on page 1-24.	
Slot	A, B, C and D	
Function	AND or XOR	
Delay Offset		
Range	Refer to Table 1-25.	
Resolution		
DTG5078	1 ps	
DTG5274	0.2 ps	
Lead Delay	Refer to Figure 1-7 for definition and Figure 1-8 for maximum lead delay.	
Range	Refer to Table 1-26.	
Resolution		
DTG5078	1 ps	
DTG5274	0.2 ps	
✓Accuracy	The timing reference is the lead edge which lead delay of each channel set to 0 ns. Skew calibration includes temperature calibration.	
DTG5078	± 100 ps, after skew calibration at + 20°C to + 30°C ambient temperature. (Slot A, B, C, D) ± 150 ps, after skew calibration at + 20°C to + 30°C ambient temperature. (Slot E, F, G, H)	Page 4-44
DTG5274	± 100 ps, after skew calibration at + 20°C to + 30°C ambient temperature.	
Trail Delay	Refer to Figure 1-7 for definition, available in RZ/R1.	
Slot	A, B, C and D	
Range	Refer to Table 1-27.	
Resolution	5 ps	
✓Accuracy	± 100 ps, after skew calibration at + 20°C to + 30°C ambient temperature.	Page 4-44
	The timing reference is the lead edge which lead delay of each channel set to 0 ns. Skew calibration includes temperature calibration.	
Duty Cycle	Refer to Figure 1-7 for definition, available in RZ/R1.	
Slot	A, B, C and D	
Range	(Trail Delay - Lead Delay) / Period x 100	
Resolution	0.1%	
Pulse Width	Refer to Figure 1-7 for definition, available in RZ/R1.	
Slot	A, B, C and D	
Range	Duty x Period / 100 or Trail Delay - Lead Delay	
Resolution	5 ps	

Table 1-22: DG Mode (cont.)

Characteristics	Description	PV reference page
Phase	Phase = Lead Delay / Period x 100 (%)	
Resolution	0.1%	
Differential Timing Offset ¹⁵		
Range	- 1.0 ns to 1.0 ns	
Resolution		
DTG5078	1 ps	
DTG5274	0.2 ps	
Skew Calibration	Only the skew between channels of same type output module is calibrated.	
Range	500 ps	
✓Accuracy		
DTG5078	100 ps, after skew calibration (Slot A, B, C, D) 200 ps, after skew calibration (Slot E, F, H, G)	Page 4-44
DTG5274	100 ps, after skew calibration	
✓Random Jitter	Measured with clock pattern (01010...). Measured by Histogram function of CSA8000 + 80E03.	
DTG5078 (using DTGM20)	< 4 ps rms, at 750 Mb/s, delay = 0.0 ns, amplitude = 0.8 V _{p-p} , data format = NRZ, slew rate = 2.25 V/ns, jitter mode = off	Page 4-50
DTG5274 (using DTGM30)	< 3 ps rms, at 2.7Gb/s, delay = 0.0 ns, amplitude = 0.8 V _{p-p} , data format = NRZ, jitter mode = off	
✓Total Jitter	Measured with PRBS2 ¹⁵⁻¹ pattern. Measured by RMS Jitter and Pk-Pk Jitter in Measurement function of CSA8000 + 80E03.	
DTG5078 (using DTGM20)	< 18 ps rms, (< 85 ps _{p-p} , typical), at 750 Mb/s, delay = 0.0 ns, amplitude = 0.8 V, Data Format = NRZ, and Jitter mode off	Page 4-53
DTG5274 (using DTGM30)	< 16 ps rms, (< 60 ps _{p-p} , typical), at 2.7 Gb/s, delay = 0.0 ns, amplitude = 0.8 V, Data Format = NRZ, and Jitter mode off	
Cross Point ¹⁶		
Slot	A, B, C, and D	
Range	30% to 70%	
Resolution	2%	

Table 1-22: DG Mode (cont.)

Characteristics	Description	PV reference page
Jitter Performance ¹⁷		
Mode	All Pattern Jitter, Partial Pattern Jitter	
All Pattern Jitter		
Jitter Profile	Sine, Gaussian Noise, Square, and Triangle.	Page 4-38
Jitter Frequency	0.015 Hz to 1.56MHz	
Jitter Frequency Resolution	4 digits or 1 mHz	
Jitter Amplitude	Refer to Table 1-28.	
Resolution	10 ps or 0.01 UI	
Partial Pattern Jitter		
Jitter Profile	Sine, Gaussian Noise, Square, and Triangle.	Page 4-40
Jitter Frequency	0.015 Hz to 1.56MHz	
Jitter Frequency Resolution	4 digits or 1 mHz	
Jitter Amplitude	Refer to Table 1-28.	
Resolution	10 ps or 0.01 UI	

- ¹⁵ Lead Delay + Differential Timing Offset have to be within the range of Lead Delay. Trail Delay + Differential Timing Offset have to be within the range of Trail Delay.
- ¹⁶ This function is available when the DTGM30 output module is used and the data format is set to NRZ.
- ¹⁷ Jitter Performance is available only for Ch1 in slot A. When this function is activated, Ch2 in slot A output is disabled.

Table 1-23: Clock Range in NRZ

Clock		Period		Hardware Clock	Vector Rate	Minimum Block Length in Hardware Sequence (DTG5274/DTG5078)	Block Size Granularity (DTG5274/DTG5078)
From	To	From	To				
Max Freq.	400 Mb/s	Min Period	2.5 ns	>400 MHz	1	960/240	4/1
400 Mb/s	200 Mb/s	2.5 ns	5 ns	800 MHz to 400 MHz	2	480/120	2/1
200 Mb/s	100 Mb/s	5 ns	10 ns		4	240/60	1/1
100 Mb/s	50 Mb/s	10 ns	20 ns		8	120/30	
50 Mb/s	25 Mb/s	20 ns	40 ns		16	60/15	
40 Mb/s	20 Mb/s	25 ns	50 ns		20	48/12	
20 Mb/s	10 Mb/s	50 ns	100 ns		40	24/6	
10 Mb/s	5 Mb/s	100 ns	200 ns		80	12/3	
5 Mb/s	2.5 Mb/s	200 ns	400 ns		160	6/2	
4 Mb/s	2 Mb/s	250 ns	500 ns		200	5/2	
2 Mb/s	1 Mb/s	500 ns	1 μ s		400	3/1	
1 Mb/s	500 kb/s	1 μ s	2 μ s		800	2/1	
500 kb/s	250 kb/s	2 μ s	4 μ s		1600	1/1	
400 kb/s	200 kb/s	2.5 μ s	5 μ s		2000		
200 kb/s	100 kb/s	5 μ s	10 μ s		4000		
100 kb/s	50 kb/s	10 μ s	20 μ s		8000		

Table 1-24: Clock Range in RZ/R1

Clock		Period		Hardware Clock	Vector Rate	Minimum Block Length in Hardware Sequence (DTG5274/DTG5078)	Block Size Granularity (DTG5274/DTG5078)
From	To	From	To				
Max Freq.	200 Mb/s	-	5 ns	>400 MHz	2	480/120	2/1
200 Mb/s	100 Mb/s	5 ns	10 ns	800 MHz to 400 MHz	4	240/60	1/1
100 Mb/s	50 Mb/s	10 ns	20 ns		8	120/30	
50 Mb/s	25 Mb/s	20 ns	40 ns		16	60/15	
40 Mb/s	20 Mb/s	25 ns	50 ns		20	48/12	
20 Mb/s	10 Mb/s	50 ns	100 ns		40	24/6	
10 Mb/s	5 Mb/s	100 ns	200 ns		80	12/3	
5 Mb/s	2.5 Mb/s	200 ns	400 ns		160	6/2	
4 Mb/s	2 Mb/s	250 ns	500 ns		200	5/2	
2 Mb/s	1 Mb/s	500 ns	1 μ s		400	3/1	
1 Mb/s	500 kb/s	1 μ s	2 μ s		800	2/1	
500 kb/s	250 kb/s	2 μ s	4 μ s		1600	1/1	
400 kb/s	200 kb/s	2.5 μ s	5 μ s		2000		
200 kb/s	100 kb/s	5 μ s	10 μ s		4000		
100 kb/s	50 kb/s	10 μ s	20 μ s		8000		

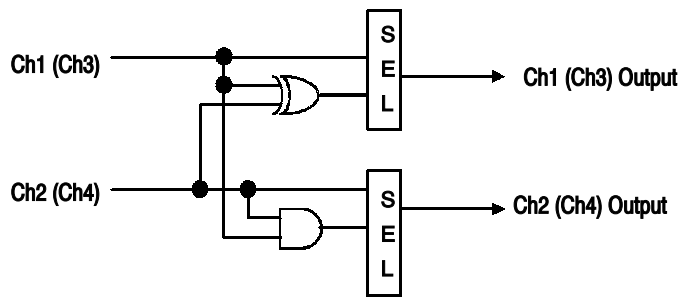
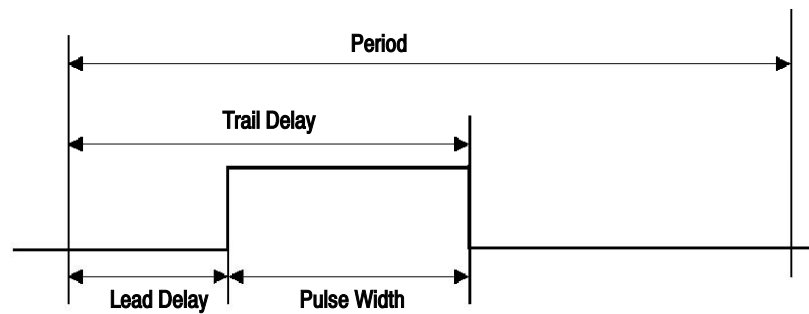

Figure 1-6: Channel addition function

Table 1-25: Delay Offset

Long Delay	Format	Period	Delay Offset
Off	---	---	0 to 5 ns
On	NRZ	≥ 1.25 ns	SW Sequence: 0 to 600 ns HW Sequence: 0 to 300 ns
		< 1.25 ns	SW Sequence: 0 to 480 x Period HW Sequence: 0 to 240 x Period
	RZ/R1	≥ 2.5 ns	SW Sequence: 0 to 600 ns HW Sequence: 0 to 300 ns
		< 2.5 ns	SW Sequence: 0 to 240 x Period HW Sequence: 0 to 120 x Period



$$\text{Phase} = \text{Lead Delay} / \text{Period} \times 100 (\%)$$

$$\text{Duty} = \text{Pulse Width} / \text{Period} \times 100 (\%)$$

Figure 1-7: The definitions of Lead/Trail Delay and Pulse Width

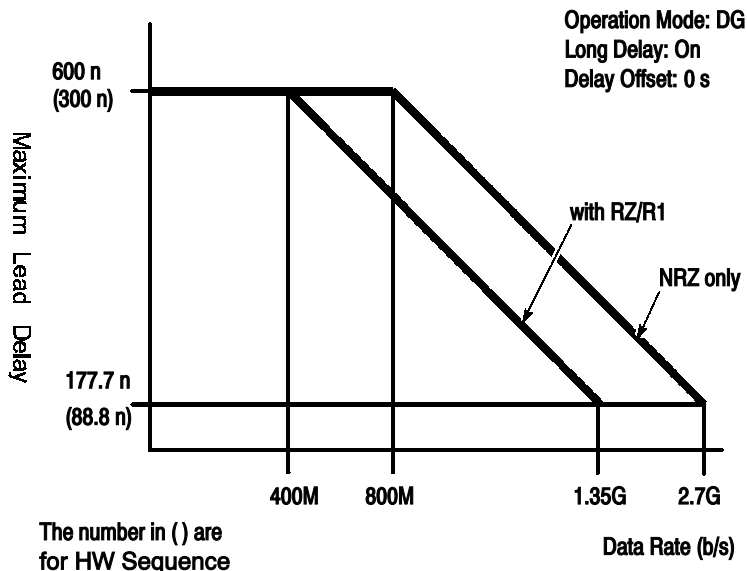

Figure 1-8: Maximum Lead Delay

Table 1-26: Lead Delay

Long Delay	Format	Period	Lead Delay
Off	---	---	0 (-Delay Offset) to 5 ns (-Delay Offset) ¹⁸
On	NRZ	≥ 1.25 ns	SW Sequence: 0 (-Delay Offset) to 600 ns (-Delay Offset) ¹⁸ HW Sequence: 0 (-Delay Offset) to 300 ns (-Delay Offset) ¹⁸
		< 1.25 ns	SW Sequence: 0 (-Delay Offset) to 480 x Period (-Delay Offset) ¹⁸ HW Sequence: 0 (-Delay Offset) to 280 x Period (-Delay Offset) ¹⁸
	RZ/R1	≥ 2.5 ns	SW Sequence: 0 (-Delay Offset) to 600 ns (-Delay Offset) ¹⁸ HW Sequence: 0 (-Delay Offset) to 300 ns (-Delay Offset) ¹⁸
		< 2.5 ns	SW Sequence: 0 (-Delay Offset) to 240 x Period (-Delay Offset) ¹⁸ HW Sequence: 0 (-Delay Offset) to 120 x Period (-Delay Offset) ¹⁸

¹⁸ It should be from 0% to 100% in Duty conversion and Pulse Width is from 290 ps to (Period - 290 ps).

Table 1-27: Trail Delay

Long Delay	Period	Trail Delay
Off	< 10 ns	290 ps (-Delay Offset) to 5 ns + Period / 2(-Delay Offset) ^{19, 20}
	≥ 10 ns	Period / 2 - Delay Offset to 5 ns + Period / 2 (- Delay Offset) ²⁰
On	---	See footnote 20

¹⁹ When the jitter generation is enabled, the range of trail delay for mainframe 1, slot A, CH1 is set to as follows:

290 ps (- Delay Offset) to 5 ns + 290 ps (- Delay Offset)

²⁰ It should be from 0% to 100% in Duty conversion and Pulse Width is from 290 ps to (Period - 290 ps).

Table 1-28: Jitter Amplitude

Jitter Edge	Data Format	Jitter Mode	Jitter Profile	Maximum Jitter Amplitude (UI p-p)
Both	NRZ	All Pattern Jitter	Sine	The larger one of the numerical values drawn by the formula below. $(1 - \text{Minimum Pulse Width} / \text{Period}) * 9.9e5 / Fj$ or $1 - \text{Minimum Pulse Width} / \text{Period}$ <i>Note: Condition 1 should be fulfilled. See Condition 1 below.</i>
			Others	1 - 290 ps / Period
		Partial Pattern Jitter	Any	<i>Note: Condition 1 should be fulfilled.</i>
	RZ/R1	All Pattern Jitter	Sine	$(\text{Period} - \text{Pulse Width} - 290 \text{ ps}) / \text{Period} * 9.9e5 / Fj$ <i>Note: Condition 1 should be fulfilled.</i>
			Others	$(\text{Period} - \text{Pulse Width} - 290 \text{ ps}) / \text{Period}$ <i>Note: Condition 1 should be fulfilled.</i>
		Partial Pattern Jitter	Any	<i>Note: Condition 1 should be fulfilled.</i>
Rise/Fall	NRZ	Any	Any	$(\text{Period} - 290 \text{ ps}) / \text{Period} * 2$ <i>Note: Condition 1 should be fulfilled.</i>
	RZ/R1	Any	Any	$(\min(\text{Pulse Width}, \text{Period} - \text{Pulse Width}) - 290 \text{ ps}) / \text{Period} * 2$ <i>Note: Condition 1 should be fulfilled.</i>

Fj: Jitter Frequency

Ajui_pp: Jitter Amplitude expressed with Ulpk-pk

Ajui_rms: Jitter Amplitude expressed with Ulrms

Ajs_pp: Jitter Amplitude expressed with s pk-pk

Ajs_rms: Jitter Amplitude expressed with s rms

Specifications

$$A_{\text{uji_pp}} * \text{Period} = A_{\text{js_pp}}$$

$$A_{\text{uji_rms}} * \text{Period} = A_{\text{js_rms}}$$

Condition 1

$$\text{Lead Delay} + A_{\text{js_pp}}/2 \leq \text{Maximum of Lead Delay and}$$

$$\text{Lead Delay} - A_{\text{js_pp}}/2 \geq \text{Minimum of Lead Delay}$$

If Ch1 is set to RZ/R1, the following condition 2 should be also fulfilled.

Condition 2

$$\text{Trail Delay} + A_{\text{js_pp}}/2 \leq \text{Maximum of Trail Delay and}$$

$$\text{Trail Delay} - A_{\text{js_pp}}/2 \geq \text{Minimum of Trail Delay}$$

Table 1-29: PG Mode

Characteristics	Description	PV reference page
Slot	A, B, C and D. <i>Note: Slot E, F, G and H are not available in PG Mode.</i>	
Frequency		
DTG5078	50 kHz to 375 MHz	
DTG5274	50 kHz to 1.35 GHz	
Frequency Resolution		
Internal Clock	8 digits	
External Clock	4 digits	
External Phase Lock In	4 digits	
Run Mode	Continuous or Burst	
Burst Count	1 to 65,536	
Pulse Rate	Off, 1/1, 1/2, 1/4, 1/8, or 1/16	
Channel Addition	Refer to Figure 1-6 on page 1-24.	
Slot	A, B, C, and D <i>Note: Slot E, F, G and H are not available in DTG5078.</i>	
Function	AND or XOR	
Delay Offset		
Range	0 to 3 μs	
DTG5078	1 ps	
DTG5274	0.2 ps	
Lead Delay	Refer to Figure 1-7 for definition.	
Range ²¹		
>3 μs	0 (-Delay Offset) to Period (-Delay Offset)	
<3 μs	0 (-Delay Offset) to 3 μs (-Delay Offset)	
Resolution ²¹		
DTG5078	1 ps	

Table 1-29: PG Mode (cont.)

Characteristics	Description	PV reference page
DTG5274	0.2 ps	
✓Accuracy ²²		
DTG5078	± 100 ps, after skew calibration at + 20°C to + 30°C ambient temperature.	Page 4-44
DTG5274		
Trail Delay	Refer to Figure 1-7 for definition.	
Resolution ²³	5 ps	
✓Accuracy ²²	± 100 ps, after skew calibration at + 20°C to + 30°C ambient temperature.	Page 4-44
Duty Cycle	Refer to Figure 1-7 for definition.	
Range	(Trail Delay - Lead Delay) / Period x Pulse Rate x 100	
Resolution	0.1%	
Pulse Width	Refer to Figure 1-7 for definition.	
Range	Duty x Period x Pulse Rate / 100 or Trail Delay - Lead Delay	
Resolution	5 ps	
Phase	Phase = Lead Delay / Period x Pulse Rate x 100 (%)	
Resolution	0.1%	
Differential Timing Offset ²⁴		
Range	- 1.0 ns to 1.0 ns	
Resolution		
DTG5078	1 ps	
DTG5274	0.2 ps	
Skew Calibration	Only the skew between channels of same type output module is calibrated.	
Range	500 ps	
✓Accuracy		
DTG5078	100 ps, after skew calibration	Page 4-44
DTG5274	100 ps, after skew calibration	
✓Random Jitter	Measured by Histogram function of CSA8000 + 80E03.	
DTG5078 (using DTGM20)	< 4 ps rms, at 375 MHz, delay = 0.0 ns, amplitude = 0.8 V _{p-p} , slew rate = 2.25 V/ns, jitter mode = off	Page 4-50
DTG5274 (using DTGM30)	< 4 ps rms, at 1.35 GHz, delay = 0.0 ns, amplitude = 0.8 V _{p-p} , jitter mode = off	

²¹ It should be from 0% to 100% in Duty conversion and Pulse Width is from 290 ps to (Period - 290 ps).

²² The timing reference is the lead edge which lead delay of each channel set to 0 ns.
Skew calibration includes temperature calibration.

²³ It should be from 0% to 100% in Duty conversion and Pulse Width is from 290 ps to (Period x Pulse Rate - 290 ps).

²⁴ Lead Delay + Differential Timing Offset have to be within the range of Lead Delay.
Trail Delay + Differential Timing Offset have to be within the range of Trail Delay.

Output Module

Table 1-30: DTGM10

Characteristics	Description	PV reference page
Connector	SMA (4 ea)	
Output Signal Type	Single-end	
Number of channels	4 channels when used in DTG5078 2 channels when used in DTG5274	
Source Impedance	50 Ω	
Polarity	Normal or Invert	
Output Voltage ²⁵		
High Level (VOH) range	-1.25 V to + 2.00 V into 50 Ω to GND -2.50 V to + 7.00 V into 1 M Ω to GND	
Low Level (VOL) range	-1.50 V to + 1.75 V into 50 Ω to GND -3.00 V to + 6.50 V into 1 M Ω to GND	
Amplitude (VOH - VOL) range	0.25 V _{p-p} to 3.50 V _{p-p} into 50 Ω to GND 0.50 V _{p-p} to 10.00 V _{p-p} into 1 M Ω to GND	
Offset ((VOH + VOL) / 2) range	Depends on the limit of VOH and VOL set by the user.	
Resolution	5 mV	
Maximum Output Voltage	+ 7.0 V	
Minimum Output Voltage	- 3.0 V	
✓DC Accuracy	($\pm 3\%$ of the set value) ± 50 mV into 50 Ω to GND, after level calibration at + 20°C to + 30°C ambient temperature.	Page 4-62
Maximum Output Current	± 40 mA Refer to Figure 1-10 for the equivalent circuit.	
Rise /Fall Time (20% to 80%), typical		
at high 1.0 V, low 0 V	< 540 ps, into 50 Ω to GND	
at high 2.0 V, low -1.0 V	< 1.5 ns, into 50 Ω to GND	
Slew Rate Control		
Range	0.65 V/ns to 1.30 V/ns, into 50 Ω to GND	
Resolution	10 mV/ns	
Aberration, typical		
Positive Overshoot	<16%	
Negative Overshoot	<16%	

²⁵ Output voltage (Vout) should fulfill the following two conditions.

R_L = Term R, Vtt = Term V

$$1) -0.04 \times R_L + V_{tt} \leq V_{out} \leq 0.04 \times R_L + V_{tt}$$

$$2) -3.00 \leq V_{out} \leq 7.00$$

Note. These conditions are automatically fulfilled, when setup.

Table 1-31: DTGM20

Characteristics	Description	PV reference page
Connector	SMA (4 ea)	
Output Signal Type	Single-end	
Number of channels	4 channels when used in DTG5078 2 channels when used in DTG5274	
Source Impedance	50 Ω	
Polarity	Normal or Invert	
Output Voltage ²⁶		
High Level (VOH)	-0.90 V to + 2.5 V into 50 Ω to GND -1.80 V to + 5.0 V into 1 M Ω to GND	
Low Level (VOL)	-1.00 V to +2.40 V into 50 Ω to GND -2.00 V to + 4.80 V into 1 M Ω to GND	
Amplitude (VOH - VOL)	0.10 V _{p-p} to 3.50 V _{p-p} into 50 Ω to GND 0.20 V _{p-p} to 7.00 V _{p-p} into 1 M Ω to GND	
Offset ((VOH + VOL) / 2)	Depends on the limit of VOH and VOL set by the user.	
Maximum Output Voltage	+ 5.0 V	
Minimum Output Voltage	- 2.0 V	
Resolution	5 mV	
✓DC Accuracy	($\pm 3\%$ of the set value) ± 50 mV into 50 Ω to GND, after level calibration at + 20°C to + 30°C ambient temperature.	Page 4-62
Maximum Output Current	± 80 mA Refer to Figure 1-10 for the equivalent circuit.	
Rise /Fall Time (20% to 80%), typical		
at high 1.0 V, low 0 V	< 340 ps, into 50 Ω to GND	
at high 2.0 V, low -1.0 V	< 760 ps, into 50 Ω to GND	
Slew Rate Control		
Range	0.63 V/ns to 2.25 V/ns, into 50 Ω to GND	
Resolution	10 mV/ns	
Aberration, typical		
Positive Overshoot	<15%	
Negative Overshoot	<15%	

²⁶ Output voltage (Vout) should fulfill the following two conditions.

$R_L = \text{Term R}$, $V_{tt} = \text{Term V}$

$$1) -0.08 \times R_L + V_{tt} \leq V_{out} \leq 0.08 \times R_L + V_{tt}$$

$$2) -2.00 \leq V_{out} \leq 5.00$$

Note. These conditions are automatically fulfilled, when setup.

Table 1-32: DTGM30

Characteristics	Description	PV reference page
Connector	SMA (4 ea)	
Output Signal Type	Complementary	
Number of channels	2	
Source Impedance	50 Ω	
Polarity	Normal or Invert	
Output Voltage	Refer to Figure 1-9.	
High Level (VOH) ²⁷	-1.00 V to + 2.47 V into 50 Ω to GND -1.94 V to + 7.00 V into 1MΩ to GND	
Low Level (VOL) ²⁸	-2.00 V to + 2.44 V into 50 Ω to GND -2.00 V to + 6.94 V into 1MΩ to GND	
Amplitude (VOH - VOL) ²⁹	30 mV _{p-p} to 1.25 V _{p-p} into 50 Ω to GND 60 mV _{p-p} to 2.50 V _{p-p} into 1MΩ to GND	
Offset ((VOH + VOL) / 2)	Depends on the limit of VOH and VOL set by the user.	
Maximum Output Voltage	+ 7.0 V	
Minimum Output Voltage	- 2.0 V	
Resolution	5 mV	
✓DC Accuracy	(± 3% of the set value) ± 50mV into 50 Ω to GND, after level calibration at + 20°C to + 30°C ambient temperature.	Page 4-62
Maximum Output Current	± 80 mA Refer to Figure 1-11 for the equivalent circuit.	
Rise /Fall Time (20% to 80%), typical		
at high 0.1 V, low 0 V	< 95 ps into 50 Ω to GND	
at high 1.0 V, low 0 V	< 110 ps into 50 Ω to GND	
Aberration, typical		
Positive Overshoot	<10%	
Negative Overshoot	<10%	

²⁷ High level (VoH) should fulfill the following formulas.

$R_L = \text{Term R, } V_{tt} = \text{Term V}$

$$VOH \leq 7.00$$

$$VOH \leq (7.00 \times RL + 50 \times V_{tt}) / (RL + 50)$$

$$VOH \leq RL / 50 \times (2.5 - 0.06 \times RL / (RL + 50)) + V_{tt}$$

$$VOH \geq (-2.00 \times RL + 50 \times V_{tt}) / (RL + 50)$$

$$VOH \geq V_{tt} - RL / 50$$

28 Low level (VOL) should fulfill the following formulas.

$R_L = \text{Term R, } V_{tt} = \text{Term V}$

$$VOL \geq -2.00$$

$$VOL \geq (50 \times V_{tt} - 4.5 \times RL) / (RL + 50)$$

$$VOL \geq V_{tt} - RL (0.02 + 2.5 / (RL + 50))$$

$$VOL < ((2.5 - 0.06) \times RL / 50) + V_{tt}$$

29 Amplitude should fulfill the following formulas.

$R_L = \text{Term R, } V_{tt} = \text{Term V}$

$$VOH - VOL > 2 \times (V_{tt} - RL/50 - \text{Offset})$$

$$VOH - VOL > 2 \times ((RL \times (-2) + 50 \times V_{tt}) / (RL + 50) - \text{Offset})$$

$$VOH - VOL < 2 \times ((2.5 \times RL - 50 \times \text{Offset} + 50 \times V_{tt}) / (2 \times RL + 50))$$

$$VOH - VOL < 2 \times ((7 \times RL - 50 \times V_{tt}) / (RL + 50) - \text{Offset})$$

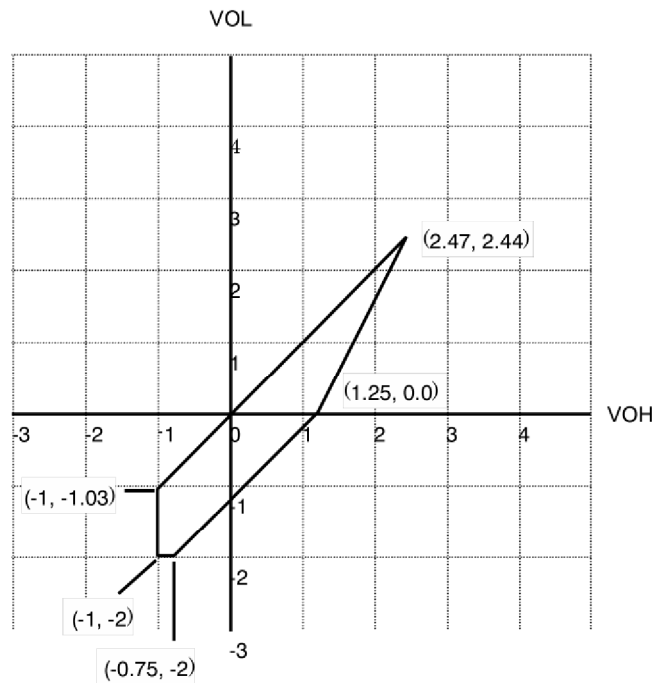

Figure 1-9: Output voltage window and clock out (DTGM30)

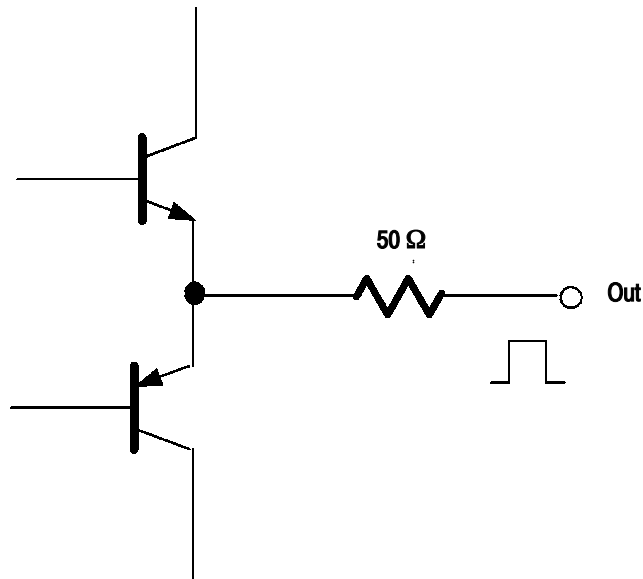

Figure 1-10: Equivalent circuit of DTGM10 and DTGM20 outputs

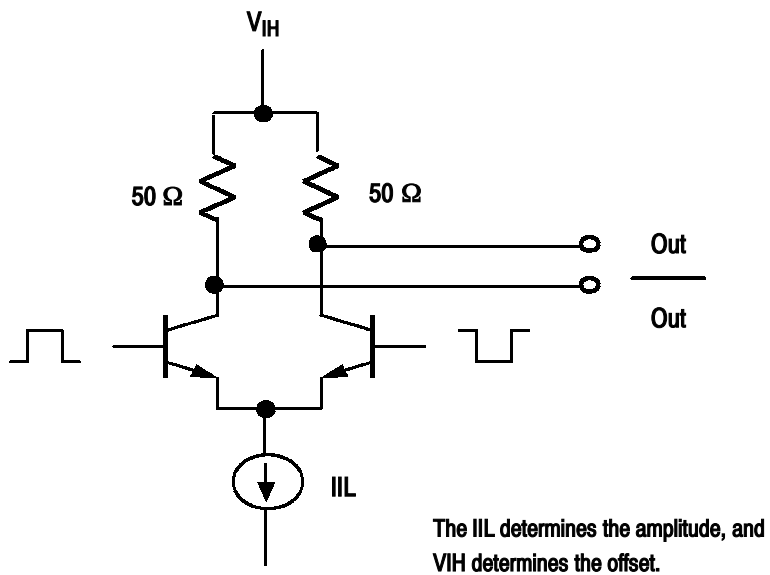

Figure 1-11: Equivalent circuit of DTGM30 output

Miscellaneous

Table 1-33: Mechanical

Characteristics	Description
Net weight	
DTG5078	approx. 17.5 kg (38.6 lb)
DTG5274	approx. 17.0 kg (37.5 lb)
DTGM10	approx. 0.25 kg (0.55 lb)
DTGM20	approx. 0.26 kg (0.57 lb)
DTGM30	approx. 0.27 kg (0.60 lb)
Net weight with package	
DTG5078	approx. 24.0 kg (52.9 lb)
DTG5274	approx. 23.5 kg (51.8 lb)
Dimensions	
DTG5078/DTG5274	Height 266 mm (10.5 in) 284 mm (11.3 in) with bottom feet
	Width 445 mm (17.5 in) 459 mm (18.1 in) with side handle
	Length 462 mm (18.2 in) 502 mm (19.8 in) with rear feet
DTGM10/DTGM20/DTGM30	Height 33 mm (1.3 in)
	Width 84 mm (3.3 in)
	Length 133 mm (5.2 in)
Dimensions with package	
DTG5078/DTG5274	Height 500 mm (19.7 in)
	Width 600 mm (23.6 in)
	Length 790 mm (31.1 in)
DTGM10/DTGM20/DTGM30	Height 83 mm (3.3 in)
	Width 238 mm (9.4 in)
	Length 227 mm (8.9 in)

Specifications

Table 1-34: Installation requirement

Characteristics	Description
Heat dissipation	
Maximum power	600 VA
Dissipation (fully loaded)	Maximum line current is 5.5 Arms at 50 Hz, 90 V line.
Surge current	30 A (25°C) peak for ≤ 5 line cycles, after the instrument has been turned off for at least 30s
Cooling clearance	Top: 2 cm (0.8 in) Bottom: 2 cm (0.8 in) <i>NOTE: The feet on the bottom provide the required clearance when set on a flat surface.</i>
	Sides 15 cm (6 in)
	Rear 7.5 cm (3 in)

Table 1-35: Environmental

Characteristics	Description
Atmospherics	
Temperature	
Operating ³⁰	+ 10°C to + 40°C
Nonoperating	- 20°C to + 60°C
Temperature Gradient	
Operating	$\leq 15^\circ\text{C}$ per hour (No Condensation)
Nonoperating	$\leq 30^\circ\text{C}$ per hour (No Condensation)
Relative humidity	
Operating	20% to 80% (no condensation) Maximum wet-bulb temperature 29.4°C
Nonoperating	5% to 90% (no condensation) Maximum wet-bulb temperature 40.0°C
Altitude	(Hard disk drive restriction)
Operating	Up to 3,000 m (10,000 ft) Maximum operating temperature decreases 1°C each 300 m (1,000 ft) above 1,500 m (5,000 ft)
Nonoperating	Up to 12,000 m (40,000 ft)

Table 1-35: Environmental (cont.)

Characteristics	Description
Dynamics	
Random Vibration	
Operating	2.65 m/s ² rms (0.27 Grm), from 5 Hz to 500 Hz, 10 minutes
Nonoperating	22.36 m/s ² rms (2.28 Grm), from 5 Hz to 500 Hz, 10 minutes
Shock	
Nonoperating	294 m/s ² (30 G), half-sine, 11 ms duration Three shocks per axis in each direction (18 shocks total)

³⁰ **May not meet all performance specifications outside this range.**

Table 1-36: Power Supply

Characteristics	Description
Rating voltage	100 VAC to 240 VAC
Voltage range	90 VAC to 250 VAC
Frequency	47 Hz to 63 Hz
Maximum Power	560 W (600 VA maximum)
Surge Current	30 A peak (25°C) for ≤5 line cycles, after the instrument has been turned off at least 30 sec.

Table 1-37: Certifications and compliances

Characteristics	Description
<p>EC declaration of conformity</p>	<p>EC council EMC Directive 89/336/EEC, amended by 89/336/EEC; EN61326-1: 1997 Product Family Standard for Electrical Equipment for Measurement, Control, and Laboratory Use-EMC Requirements.</p> <p>Emissions:</p> <p>EN 55011 Class A Radiated and Conducted emissions EN 61000-3-2 Power Line Harmonic</p> <p>Immunity:</p> <p>EN 61000-4-2 Electrostatic Discharge Immunity EN 61000-4-3 Radiated RF Electromagnetic Field Immunity EN 61000-4-4 Electrical Fast Transient/Burst Immunity EN 61000-4-5 Surge Immunity EN 61000-4-6 Conducted Disturbances Induced by RF Field Immunity EN 61000-4-11 Power Line Interruption Immunity</p> <p>Compliance was demonstrated to the following specification as listed in the Official Journal of the European Communities:</p> <p>Low Voltage Directive 73/23/EEC, amended by 93/68/EEC EN 61010-1/A2:1995 Safety requirements for electrical equipment for measurement, control, and laboratory use</p>
<p>Australia/New Zealand declaration of conformity - EMC</p>	<p>Conforms with the following standards in accordance with the Electromagnetic Compatibility Framework:</p> <p>AS/NZS 2064.1/2 Class A radiated and Conducted Emissions</p>
<p>Safety</p> <p>Third party certification</p> <p>Self declaration</p>	<p>UL3111-1 - Standard for electrical measuring and test equipment</p> <p>CAN/CSA C22.2 No. 1010.1 - Safety requirements for electrical equipment for measurement, control and laboratory use</p> <p>IEC 61010-1/A2:1995 - Safety requirements for electrical equipment for measurement, control, and laboratory use</p>
<p>Installation category</p>	<p>Power input — Installation Category II (as defined in IEC 61010-1, Annex J)</p>
<p>Pollution degree</p>	<p>Pollution Degree 2 (as defined in IEC 61010-1)</p>

Table 1-38: Installation category and Pollution degree

Characteristics	Description	
Installation category	Terminals on this product may have different installation category designations. The installation categories are:	
	<i>Category</i>	<i>Descriptions</i>
	CAT III	Distribution-level mains (usually permanently connected). Equipment at this level is typically in a fixed industrial location
	CAT II	Local-level mains (wall sockets). Equipment at this level includes appliances, portable tools, and similar products. Equipment is usually cord-connected
	CAT I	Secondary (signal level) or battery operated circuits of electronic equipment
Pollution degree	A measure of the contaminates that could occur in the environment around and within a product. Typically the internal environment inside a product is considered to be the same as the external. Products should be used only in the environment for which they are rated.	
	<i>Category</i>	<i>Descriptions</i>
	Pollution Degree 1	No pollution or only dry, nonconductive pollution occurs. Products in this category are generally encapsulated, hermetically sealed, or located in clean rooms.
	Pollution Degree 2	Normally only dry, nonconductive pollution occurs. Occasionally a temporary conductivity that is caused by condensation must be expected. This location is a typical office/home environment. Temporary condensation occurs only when the product is out of service.
	Pollution Degree 3	Conductive pollution, or dry, nonconductive pollution that becomes conductive due to condensation. These are sheltered locations where neither temperature nor humidity is controlled. The area is protected from direct sunshine, rain, or direct wind.
	Pollution Degree 4	Pollution that generates persistent conductivity through conductive dust, rain, or snow. Typical outdoor locations.
Safety certification compliance		
Equipment type	Test and measuring	
Safety class	Class I (as defined in IEC 61010-1, Annex H) - grounded product	
Safety operating temperature range ³¹	+ 5°C to + 40°C	
Overvoltage category	Overvoltage category II (as defined in IEC 61010-1, Annex J)	

³¹ See Table 1-35.



Operating Information

Installation

This section covers installation of the data timing generator, addressing the following topics:

- *Checking the Environment Requirements* on page 2-4
- *Output Module* on page 2-5
- *Powering On the Data Timing Generator* on page 2-6
- *Setting up Windows 2000* on page 2-7
- *Shutting Down the Data Timing Generator* on page 2-8
- *Creating an Emergency Rescue Disk* on page 2-10
- *Backing Up User Files* on page 2-13
- *Installing Software* on page 2-13



CAUTION. *Be sure to create your emergency rescue disk as described on page 2-10. You may need that disk if you ever need to reinstall Windows 2000 from the data timing generator hard drive.*

Supplying Operating Power



WARNING. To avoid equipment failure and potential fire or personal shock hazards, do not exceed the maximum rated operating voltage of 250 V between the voltage-to-ground (earth) and either pole of the power source. The DTG5000 Series operates from a single-phase power source and has a three-wire power cord with a two-pole, three-terminal grounding plug. Before making connection to the power source, be sure the DTG5000 Series has a suitable two-pole, three-terminal, grounding-type plug.

To avoid personal shock hazard, do not touch conductive parts. All accessible conductive parts are directly connected through the grounding conductor of the power cord to the grounded (earth) contact of the power plug. The DTG5000 Series is safety Class 1 equipment (IEC designation).

To prevent electrical shock, remove all power from the instrument, switch the **PRINCIPAL POWER SWITCH** on the back panel to OFF, and disconnect the power cord from the instrument. Some components in the DTG5000 Series are still connected to line voltage after powering off the instrument from the front-panel ON/STBY button.

Power Cord Information

A power cord with the appropriate plug configuration is supplied with each DTG5000 Series Data Timing Generator. Table 2-1 gives the color-coding of the conductors in the power cord. If you require a power cord other than the one supplied, refer to Table 2-2.

Table 2-1: Power-cord conductor identification

Conductor	Color	Alternate Color
Ungrounded (Line)	Brown	Black
Grounded (Neutral)	Light Blue	White
Grounded (Earthing)	Green/Yellow	Green

Table 2-2: Power cord identification

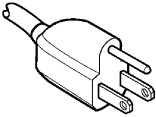
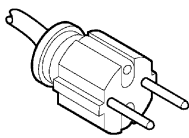
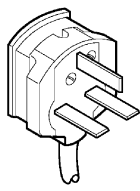
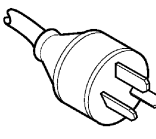
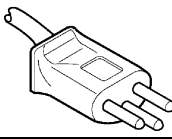
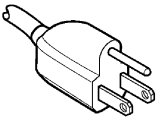
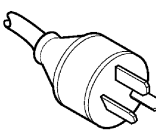
Plug configuration	Normal usage	Option number
	North America 125 V/15 A Plug NEMA 5-15P	Standard
	Europe 230 V	A1
	United Kingdom 230 V	A2
	Australia 230 V	A3
	Switzerland 230 V	A5
	Japan 100 V	A6
	China 230 V	A10
	No power cord supplied.	A99

Checking the Environment Requirements

Read this section before attempting any installation procedures. This section describes site considerations and power requirements for your data timing generator.

Site Considerations

The data timing generator is designed to operate on a bench in the normal position (on the bottom feet). For proper cooling, at least three inches (7.62 cm) of clearance is required on both sides of the data timing generator, and the bottom requires the clearance provided by the mainframe feet.

If you operate the data timing generator in the Master-Slave mode, you can stack up to two mainframes.



CAUTION. *To avoid damage to the mainframe, always close the bottom stands when you stack the mainframes.*

Using a cart is not recommended when you stack the mainframes. Doing so could result in serious damage to the cart or mainframes.

Do not operate the mainframe while it rests on its left side feet. Always place the mainframe in the normal position (on the bottom feet) while the mainframe powered-on.

Operating Requirements

Table 2-3 shows general operating requirements for the data timing generator. For more information, refer to *Specifications* on page 1-36. It covers power source, temperature, humidity and altitude information.

Table 2-3: Operating requirements

Item	Description
Operating temperature	+10°C to +40°C
Operating relative humidity	20% to 80% (No condensation)
Operating altitude	Up to 3 km (10,000 ft)
Power supply	
Rating voltage	100 V to 240 V
Voltage range	90 V to 250 V
Frequency	47 Hz to 63 Hz
Maximum power	600 VA maximum

Output Module

The DTG5000 Series Data Timing Generator mainframe and output module(s) are shipped separately. At least one output module must be installed in the mainframe slot to operate properly.

Three types of output modules can be combined in any combination. Each module can be inserted in any slot. There are functional differences between slot A to D and slot E to H. (Refer to *Mainframe and Output Configuration* on page 1-3.) It is recommended that slot A is used when only one output module is installed in the mainframe slot.

Installing the Output Module

To install the output module, first power off the mainframe using the front panel On/Standby switch.



CAUTION. *To prevent damage to the output module or mainframe, never install or remove the output module when the mainframe is powered on.*

To avoid the damage from Electro Static Discharge, please do not touche the board surface or connectors of the output module with your fingers when you handle the module.

Attach the blank panel to the mainframe module slot(s) when the output module(s) are not installed.

If the output module is not in use for a long time, attach the connector caps and SMA terminations (DTGM30) to the output module and then store the output module in the shipping carton. The connector caps and SMA terminations are provided with your output module.

1. Verify that the data timing generator mainframe is not powered on.
2. Remove the blank panel from the mainframe slot.
3. Place the output module in a compartment.
4. Gently push the output module into the slot with firm pressure.
5. Once the module is seated, tighten the two screws to secure the module to the mainframe.

Removing the Output Module

Verify that the data timing generator mainframe is not powered on.

1. Loosen the two screws.
2. Grasp the right and left screws and slowly pull the module out of the mainframe slot.

3. Attach a blank panel to the slot.

Powering On the Data Timing Generator

Follow these steps to power on the data timing generator. Refer to page 2-7 for Windows 2000 setup.

1. Connect the proper power cord from the rear panel power connector to the power system.

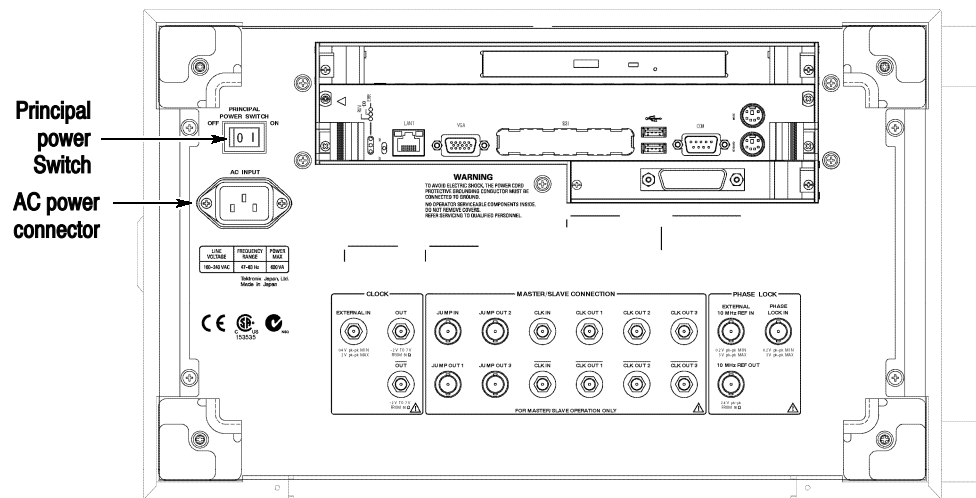

Figure 2-1: Principal power switch and AC power connector

NOTE. Connect the keyboard, mouse and other accessories before applying power to the product.

2. Turn on the principal power switch at the rear panel. (See Figure 2-1 for switch location.)
3. Push the front panel On/Standby switch to power on the data timing generator (see Figure 2-2 for the switch location).

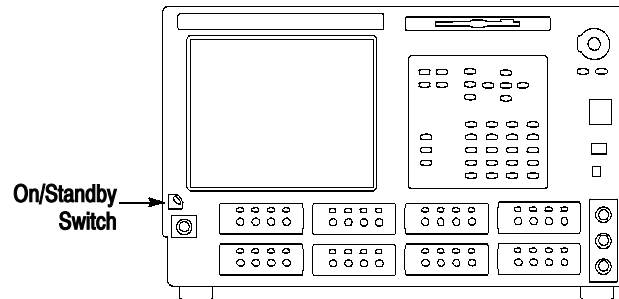

Figure 2-2: On/Standby switch location

Setting up Windows 2000

You need to set up the Windows 2000 when you first power on the data timing generator.

NOTE. Connect the keyboard and mouse before powering on the mainframe when you set up the Windows 2000.

1. Attach the standard accessory USB mouse and USB keyboard to the data timing generator mainframe. Three USB connector ports are equipped with the mainframe (two on the rear panel and one on the front right side).
2. Push the front panel On/Standby switch to power on the mainframe.
3. The Windows 2000 setup wizard appears on the data timing generator screen.
4. Follow the on-screen instructions.
5. When **Your Product Key** dialog box appears, enter the bar code number which is located at the rear panel of mainframe.
6. Click **Next** button to display **Date and Time Settings** dialog box.
7. Confirm that the Date and Time Settings information is correct, and the click **Next** button.
8. A dialog box pops up to let you know that the Windows 2000 setup has been completed.
9. Click **Restart Now**, and Windows runs.

The computer name is DTG5000, and you can log on the Windows 2000 as the following user name and password.

- User name: Administrator
- Password: dtg5000

If you want to add the user name, or want to change the password, always use the **Control Panel -> Users and Passwords**. For more information, consult Windows 2000 Help.

NOTE. *If you connect a second or third DTG5000 Series Data Timing Generator to the network, use different computer names for additional mainframes.*

Shutting Down the Data Timing Generator

When you push the front-panel On/Standby switch, the data timing generator starts a shutdown process (including a Windows shutdown) to preserve settings. This action removes power from most circuitry in the data timing generator. Avoid using the rear panel power switch or disconnecting the line cord to power off the mainframe.

The DTG5000 Series Data Timing Generator runs on Windows 2000, the shut down process is similar to a PC.

There are three ways to shut down the mainframe:

- Push the On/Standby switch
- Select the Windows **Start** menu, and then select **Shut Down...**
- Select the **File** menu from the DTG5000 software, then select **Shutdown**.

When the data timing generator settings were not changed. When the DTG5000 software is not running, or if the data timing generator settings have not changed since the mainframe start-up, the shut down process closes all the programs on Windows then restores the settings. The power is automatically shut off.

When the data timing generator settings were changed. If the DTG5000 Series Data Timing Generator settings were changed after the mainframe start-up. The dialog box shown below appears on the screen and asks if you want to save the current settings. Push any button within five seconds.

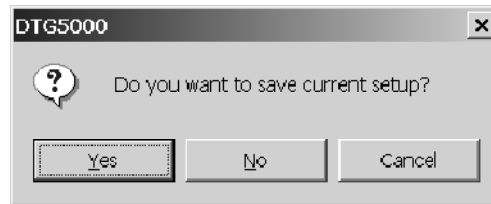

- Select **Yes** to specify the file name and location, and then select **OK** to continue the shut down process.
- Select **No** without saving the setup file and continue the shut down process.
- Select **Cancel** to abort shut down process and to return to the DTG5000 software.

If you do not select the options within five seconds, Windows forces to terminate the DTG5000 software. The **End Program** dialog appears.

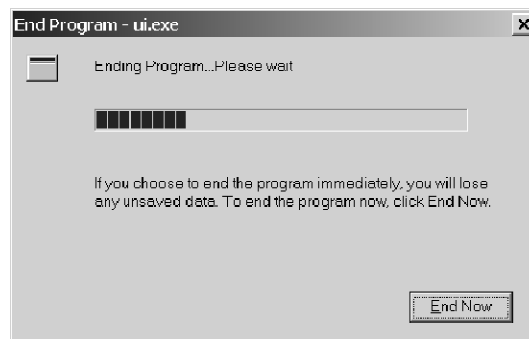

- Select **End Now** to continue the shut down process without saving the setup file.

Without any action in ten seconds, the following dialog box appears.

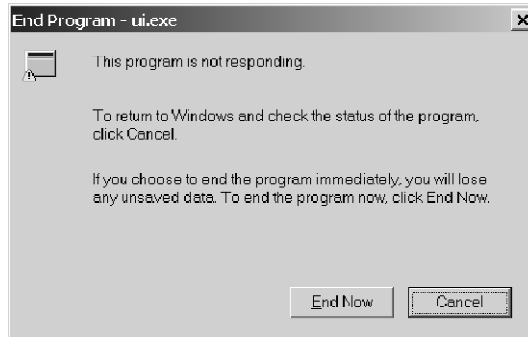

The DTG5000 software is waiting for the information about whether the user wants to save the setup information. In this case, Windows cannot terminate the DTG5000 software.

- Select **End Now** to continue the shut down process without saving the setup file.
- Select **Cancel** to return to the DTG5000 software.

In all cases, select **End Now** to exit all the Windows programs while preserving the current Windows setting. This shuts off the power to the mainframe.

To completely remove the power from the data timing generator, perform the shutdown described above. Shut off the principal power switch at the rear panel, and then disconnect the power cord from the mainframe.

NOTE. *If you push the front panel On/Standby switch for more than four seconds, the data timing generator power is forced to be shut off.*

Do not attempt to push the rear panel principal power switch before shutting down the mainframe properly.

Creating an Emergency Rescue Disk

Now that you have completed the basic installation process, you should create an emergency rescue disk that you can use to restart your data timing generator in case of a major hardware or software failure.

NOTE. *Create the emergency rescue disk and store it in a safe place. It may allow you to recover your Windows 2000 installation without rebuilding the entire data timing generator hard disk.*

The emergency rescue disk contains basic files to restart your data timing generator. Follow these steps to create the emergency rescue disk:

1. Log on the mainframe with the administrator name. Refer to page 2-7.
2. Click the Windows **Start** button, select **Program -> Accessories -> System Tools -> Backup**. The following dialog box appears.

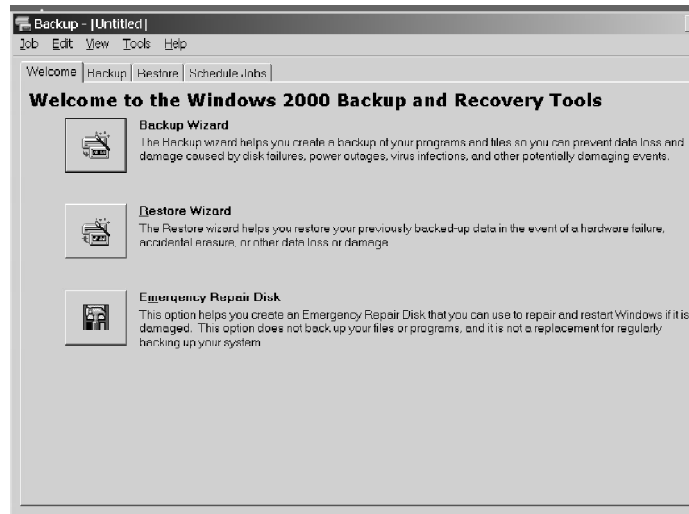

3. Insert a formatted floppy disk into the floppy disk drive, and then click **Emergency Repair Disk**.
4. The **Emergency Repair Diskette** dialog box appears.



5. Click **Also backup the registry...**, and then click **OK**.
6. Wait until the task completes. The following dialog appears.



7. Click **OK**, then remove the floppy disk and store it at a safe place.

Backing Up User Files

You should always back up your user files on a regular basis. Use the Back Up tool to back up files stored on the hard disk. The Back Up tool is located in the System Tools folder in the Accessories folder.

1. Log on the mainframe with the administrator name. Refer to page 2-7.
2. Click the Windows **Start** button, select **Program -> Accessories -> System Tools -> Backup**.
3. Click **Backup Wizard**.
4. Follow the on-screen instructions.
5. The backup tool allows you to select your backup media and to select the files and folders that you want to back up. Use the Windows online help for information on using the Backup tool. You can back up to the floppy drive or to a third-party storage device.

Installing Software

The data timing generator mainframe ships with the product software installed, so only perform the reinstallation if it becomes necessary. For more information on the software reinstallation, refer to the User Manual, volume 2.

System Diagnostics

In case of instrument problems, you may wish to run the system diagnostics. See the Self Test section on page 4-3 for more information on self tests and system diagnostics.

Operating Basics

This section contains information on the various interfaces for controlling the DTG5000 Series Data Timing Generator and basic menu operation of the instrument.

- The *Front Panel Controls* on page 2-15 provides a quick overview of front panel controls such as the knob, buttons and keys.
- The *Front Panel Connectors* on page 2-19 subsection provides a quick overview of front panel connectors.
- The *Rear Panel Connectors* on page 2-21 provides a quick overview of rear panel connectors.
- The *Display Area and Application Windows* on page 2-26 describes the overview of screen elements and the application windows.
- The *Using the Menu System* on page 2-53 provides an overview of the menu and key operations of the data timing generator.

Front Panel Controls

This section introduces you to the front panel controls of the data timing generator, which provides a brief overview on how to use the front panel key controls.

In addition to the front panel controls, you can also control the data timing generator from a keyboard and a mouse (provided with the instrument).

Navigation Keys

The MENU and SELECT buttons, TAB, ESC, and the Up, Down, Left and Right arrow keys are called navigation keys. These buttons and keys allow you to perform the data timing generator basic windows operation without using a mouse or a keyboard. Figures 2-3 shows the locations of the front-panel controls.

MENU button. Pushing the MENU button opens the pull-down menu items of the last menu bar that you opened, regardless of current selection.

To cancel the pull-down menu, push the MENU button again. Pressing the ESC key also forces the pull-down menu to disappear, however the menu bar is still active. If you press any arrow key in this state, the key operates on the menu bar area. Pressing the ESC key twice moves the focus to the lower window area.

SELECT button. The SELECT button has the same capability as the Windows standard ENTER key. This button is mainly used for the following actions:

- To make a selection on the pull-down menu items
- To open a pop-up menu in a tabular view
- To select an item in a pop-up menu
- To select **OK** or **Cancel** in the dialog box



Figure 2-3: Front panel controls

TAB key. The TAB key is used to move the focus within the window. By pressing the **SHIFT** and **TAB** keys simultaneously, you can move the focus in the reverse direction.

ESC key. The ESC key is used to cancel text input or dialog box appearance. To cancel the menu items opened with the **MENU** button, press the **ESC** key twice.

Arrow keys (Up, Down, Left and Right). The arrow keys are used for the following actions:

- To open the pull-down menus on the menu bar and move to the desired items, after pushing the **MENU** button (you can also use the knob).
- To move the current cell (cursor position) in a tabular view

- To select a radio button

When you press these buttons repeatedly the action is repeated.

DATA, LEVEL and TIMING buttons. Provide direct access to frequently used menus.

- **DATA button:** The DATA button is used to display a previously selected pattern data editing window (Data-Listing window or Data-Waveform window). While one window is displayed, pushing this button switches to the alternate window on the screen.
- **LEVEL button:** The LEVEL button is used to display the Level window and moves the focus to the previously selected items.
- **TIMING button:** The TIMING button is used to display the Timing window and moves the focus to the **Clock Frequency** or previously selected item.

Knob. The knob is used to increment or decrement a set value or select an item from a pop-up or pull-down menu. Use right or left arrow keys just under the knob to move the digit when you increment or decrement the setup value.

Digit Select arrow keys. The Digit Select arrow key is used to move the underbar to a field that contains an editable number. This will allow you to change the digit with the knob.

RUN button. The RUN button is used to control the start and stop of signal outputs.

If the signal is being output, the LED indicator lights up. To actually output the signal through the output connectors, you must turn the **Output** on in the Level window or push the front panel **ALL OUTPUTS ON/OFF** button.

PULSE GEN button. The PULSE GEN button is used to toggle between Pulse Generator and Data Generator modes. The LED lights up when the instrument is in PG mode.

MANUAL TRIGGER button. The MANUAL TRIGGER button is used to generate an internal trigger.

MANUAL EVENT button. The MANUAL EVENT button is used to generate an event signal internally.

Suffix buttons (p, G/n, M/ μ , k/m). After you complete the input with numeric keys, you can determine the unit by pushing one of the suffix buttons, without pressing the Enter key.

If you push a suffix button for a frequency, the unit is interpreted as G (giga-), M (mega-) or k (kilo-). If you push it for a time or voltage, the unit is interpreted as p (pico-), n (nano-), μ (micro-) or m (milli-).

SHIFT key. The SHIFT key has the same capability as the Shift key on a Windows PC keyboard.

ALT key. The ALT key has the same capability as the Alt key on a Windows PC keyboard.

CTRL key. The CTRL key has the same capability as the Ctrl key on a Windows PC keyboard.

ALPHA key. The ALPHA key is used to enter a character with a numeric key. Pressing the ALPHA key causes the LED to light up.

While the LED is on, the data timing generator is in the text input mode and you can use numeric keys to enter alphanumeric characters.

SPACE key. The SPACE key switches the On/Off state of a check box. Pressing the ALT and SPACE keys simultaneously displays the Control menu. See *DTG icons* on page 2-26 for details on the Control menu.

BKSP key. The BKSP key has the same capability as the Back Space key on a Windows PC keyboard.

DEL key. The DEL key has the same capability as the Delete key on a Windows PC keyboard.

ALL OUTPUTS ON/OFF button. This button is used to switch the on/off of channel output, DC output or clock output. To turn on or off of these outputs, use the Level window, DC Output window, or Time Base window, respectively. You can turn on or off the channel (or DC or clock) outputs all together by using this button, instead of switching the on/off separately.

If you push this button while at least one active channel or DC output or clock output is on, all the outputs turn off.

If you push this button while all the outputs are off, all the outputs turn on.

In the Data Generator mode, the physical channels that are not assigned to logic channel do not turn on.

Front Panel Connectors

Figure 2-4 shows the locations of the data timing generator front panel connectors.

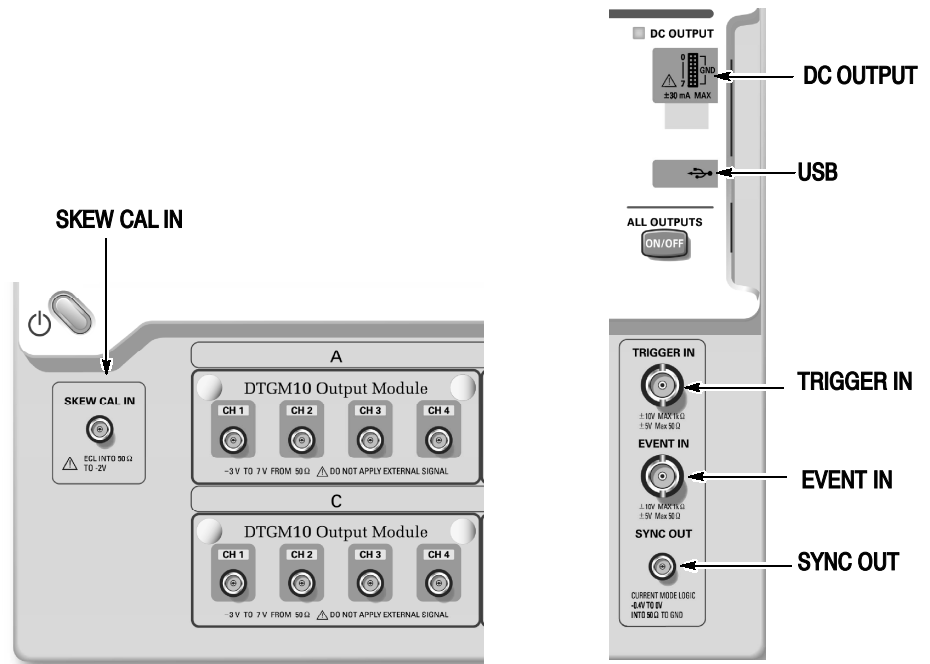

Figure 2-4: Front panel connectors



CAUTION. To prevent damage to your data timing generator, do not apply a voltage outside the specified input voltage range.

Do not apply a voltage to the output connector.

TRIGGER IN External trigger signal input connector.

Input Voltage Range.

- -5 V to +5 V, 50 Ω
- -10 V to 10 V, 1 kΩ
- Connector: BNC

EVENT IN Event signal input connector.

Input Voltage Range.

- -5 V to +5 V, 50 Ω
- -10 V to 10 V, 1 k Ω
- Connector: BNC

SYNC OUT Synchronized signal output connector for CML level.

Data Generator Mode. A pulse is output at the head of each block of the output pattern. If the block repeats, the pulse is output at each repeated block head.

Pulse Generator Mode. Single pulse is output at the timing of Burst. No signal is output in Continuous operation.

- $V_{OH} = 0$ V, $V_{OL} = -0.4$ V into 50 Ω to GND
- Connector: SMA

SKEW CAL IN Signal input connector for adjusting channel-to-channel skews.

Input Voltage Level.

- ECL into 50 Ω to -2 V
- Connector: SMA

DC OUTPUT Outputs eight channel DC voltage. This signal is independent of the output module signal.

Output Voltage Range.

- - 3.0 V to 5.0 V
- Connector: 2.54 mm 2 x 8 pin header (female)

USB Connect a USB device.

Rear Panel Connectors

Figure 2-5 shows the locations of the data timing generator rear panel connectors. Also refer to Figure 2-6 on page 2-25 for peripheral connectors and ports.

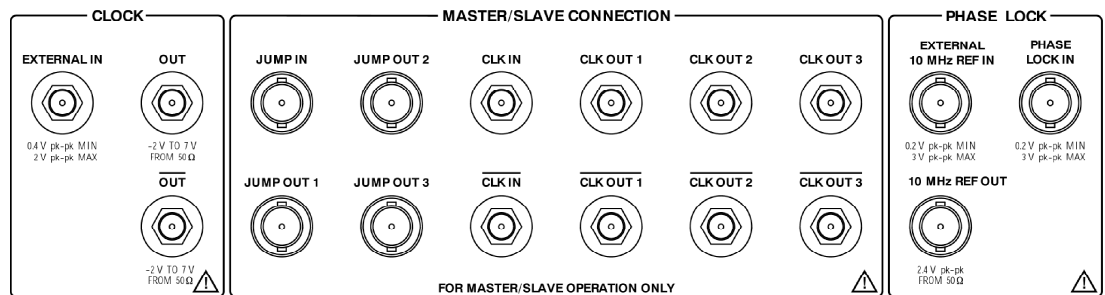
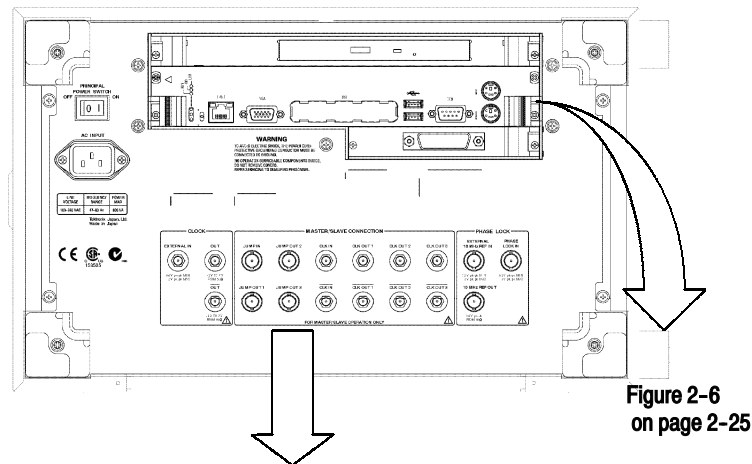

Figure 2-5: Rear panel connectors



CAUTION. To prevent damage to your data timing generator, do not apply a voltage outside the specified input voltage range.

Do not apply a voltage to the output connector.

CD-ROM drive

The CD-ROM drive is used to reinstall the DTG5000 product software or to rebuild the operating system.

COM

COM port.

Mouse

Connect a PS/2 mouse. Any USB mouse must be connected to the USB port.

Keyboard Connect a PS/2 keyboard. By connecting a keyboard and mouse to the connectors, you can perform the Windows PC operations more easily. Any USB keyboard must be connected to the USB port.

GPIB The GPIB port. Used to control the data timing generator through the GPIB.

USB (2 ea) Connect a USB device. The keyboard and mouse of the data timing generator standard accessories must be connected to the USB port.

VGA If an external display is connected to this connector, the same image as the data timing generator LCD screen is displayed.

Resolution Settings.

- The 800 by 600 setting is recommended.
- It is possible to set the data timing generator display off (from the Control Panel settings) and to display the screen image with external display. In this condition, images can be displayed at a higher resolution. If the external display is disconnected from the connector, images are displayed on the data timing generator screen at a resolution of 800 by 600 pixels, regardless of the resolution settings of the external display.

LAN LAN is a port used to connect the data timing generator to a network. Use a 10Base-T or 100BASE-T connector. In the Master-Slave operation, the Master mainframe controls the Slave machine by way of network.

CLOCK These are the external clock input/output signal connectors.

EXTERNAL IN. Connect the external clock input signal.

- Input Voltage Range: $0.4 V_{p-p}$ to $2 V_{p-p}$ into 50Ω
- Input Frequency Range:
DTG5078: 1 MHz to 750 MHz
DTG5274: 1 MHz to 2.7 GHz

OUT, $\overline{\text{OUT}}$. Outputs the clock signal. Amplitude and Offset can be set in the Time Base window.

- Output Voltage Range V_{OH} : -1.00 V to 2.47 V into 50Ω to GND
- Output Voltage Range V_{OL} : -2.00 V to 2.44 V into 50Ω to GND

- Output Voltage Amplitude: 0.03 V_{p-p} to 1.25 V_{p-p}
- Resolution: 10 mV
- Signal type: Complementary
- Connector: SMA

NOTE. A 50Ω SMA termination is attached to the data timing generator. When you use the clock out signal by single end, connect the termination to the unused connector.

Master-Slave Connection

Clock, Jump and Timing signals used for Master-Slave operation.

CLK IN, $\overline{\text{CLK IN}}$. Clock signal input connector to receive the clock signal from the master-mainframe.

- Voltage level: ECL
- Connector: SMA

CLK OUT1, CLK OUT2, CLK OUT3, $\overline{\text{CLK OUT1}}$, $\overline{\text{CLK OUT2}}$, $\overline{\text{CLK OUT3}}$. Outputs the clock signals from the master-mainframe to control the clock of slave-mainframe. Connect the CLK OUT1 to CLK IN of master-mainframe. CLK OUT3 and $\overline{\text{CLK OUT3}}$ are equipped only in DTG5078.

- Connector: SMA

JUMP IN. Signal input connector to control the sequence waveform outputs in Master-Slave operation. Connect the master-mainframe JUMP OUT_x signal to the slave-mainframe JUMP IN.

- Connector: BNC

JUMP OUT1, JUMP OUT2, JUMP OUT3. Signal output connectors to control the sequence waveform outputs in Master-Slave operation. This signal is used to control sequence waveform jumps of slave-mainframe. Connect the JUMP OUT1 to JUMP IN of master-mainframe. JUMP OUT3 is equipped only in DTG5078.

- Connector: BNC

PHASE LOCK External PLL input/output signal connectors.

PHASE LOCK IN. External PLL input signal connector.

- Input Voltage Range: 0.2 V_{p-p} to 3.0 V_{p-p}
- Input Frequency Range: 1 MHz to 200 MHz
- Impedance: 50 Ω, AC coupled
- Connector: BNC

EXTERNAL 10 MHz REF IN. External 10 MHz reference clock input signal connector.

- Input Voltage Range: 0.2 V_{p-p} to 3.0 V_{p-p}
- Input Frequency Range: 10 MHz ± 0.1 MHz
- Impedance: 50 Ω, AC coupled
- Connector: BNC

10 MHz REF OUT. Outputs a 10 MHz reference clock signal.

- Output Voltage Amplitude:
1.2 V_{p-p} into 50 Ω to GND
2.4 V_{p-p} into 1 MΩ to GND
- Impedance: 50 Ω, AC coupled
- Connector: BNC

Peripherals on the Rear Panel

The peripheral connections are the same as those you would make on a personal computer. The connection points are shown in Figure 2-6. See Table 2-4 for additional connection information.



CAUTION. To avoid product damage, power off the data timing generator or place the data timing generator in Standby power mode before installing any accessories except a USB mouse or a USB keyboard to the mainframe connectors. (You can connect or disconnect USB devices while power is supplied to the mainframe.) See Powering Off the Data Timing Generator on page 2-8.

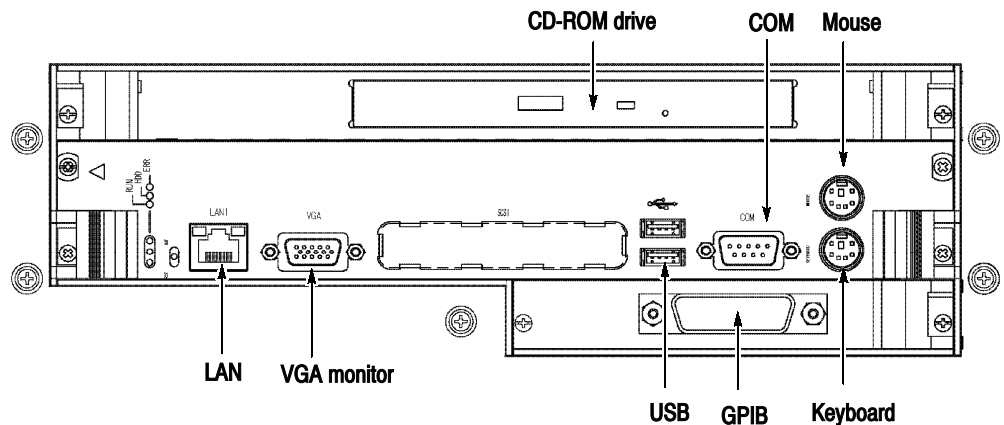

Figure 2-6: Locations of peripheral connectors on rear panel

Table 2-4: Additional connection information

Item	Description
Monitor	If you use an external monitor with the data timing generator mainframe screen, the resolution of the external monitor is fixed to 800 x 600. If you select the external monitor only, high resolution display can be possible. You can set the resolution by using the Windows 2000 control panel.
Printer	If you connect the printer directly to the data timing generator, connect the USB printer to a USB connector port of the mainframe. You cannot connect the parallel printer directly to the mainframe. If your data timing generator is connected to LAN, you can use a network printer.

Display Area and Application Windows

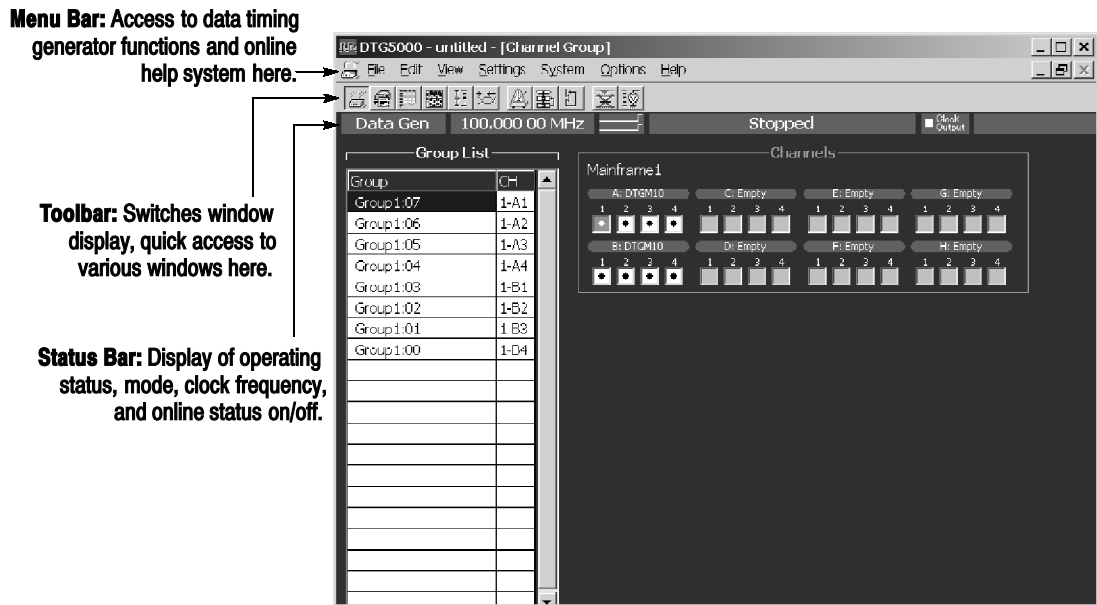
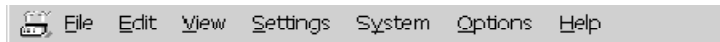

Figure 2-7: Screen elements just after the power on

Menu Bar You can access each of the menu bar items by using the **MENU** button and the Up, Down, Left and/or Right arrow keys.



DTG icons (control box menus). These menus control the data timing generator window operations.

Table 2-5: Control box menus

Items	Description
Resize	Restores the window to the initial display size.
Move	Moves the window. You can use the Up, Down, Left and/or Right arrow key to move the window in the direction. Press the Enter key for completion.
Size	Resizes the window. First, press the Up, Down, Left or Right arrow key to enable one of the window sides. Pressing another pair of arrow keys enables the window corner. Press the Enter key for completion.
Minimize	Minimizes the window.

Table 2-5: Control box menus (cont.)

Items	Description
Maximize	Maximizes the window.
Close (Alt + F4)	Closes current window.

File Menu. The File menu controls the data timing generator file operations.

Table 2-6: File menus

Items	Description
Default Setup	Restores the data timing generator settings to the defaults.
Open Setup...	Opens the saved settings file.
Save Setup	Saves current settings, overwriting the old ones.
Save Setup As...	Saves current settings in a new file under a name you specify.
Import...	Imports a file created with another application. (Data-Listing and Data-Waveform window)
Exit	Exits the DTG5000 software.
Shutdown	Exits all the applications including the DTG5000 software and shuts down Windows, then powers off the DTG5000 series mainframe. This menu cannot be selected in the offline mode.

Edit Menu. The Edit menu shows various pull-down menus depending on the active window or the items specified by cursor. Refer to each window description.

View Menu. The View menu controls the data timing generator display.

Table 2-7: View menus

Items	Description
View by Channel	Displays data for channel by channel. (Data-Listing, Data-Waveform, Level, and Timing window)
View by Group	Displays data for group by group. (Data-Listing, Data-Waveform, Level, and Timing window)
Zoom In	Doubles the size of the view horizontally, with the cursor position as the base. (Data-Waveform window)
Zoom Out	Halves the size of the view horizontally, with the cursor position as the base. (Data-Waveform window)

Table 2-7: View menus (cont.)

Items	Description
View with Timing	When the data timing generator displays the data pattern, the Timing window setup information such as Format, Delay, Pulse Width and Polarity are included. (Data-Waveform window)
Move Up	<p>Moves current-selected line upwards one line. (Timing and Level window)</p> <p>Moves current group position upwards one line. (Data-Waveform window)</p>
Move Down	<p>Moves current-selected line down one line. (Timing and Level window)</p> <p>Moves current group position down one line. (Data-Waveform window)</p>
Move Left	Moves current group position left by one. (Data-Listing window)
Move Right	Moves current group position right by one. (Data-Listing window)
Reset Order	<p>Arranges the channels within the current group according to their numbers. (Timing and Level window)</p> <p>This command has no influence on viewing in the Data-Listing or Data-Waveform window.</p>
Properties...	<p>Specifies the display format such as Radix, Signs, Magnification display. (Data-Listing and Data-Waveform window)</p> <p>Specifies how data is listed when viewed by group.</p>
Toolbar	Hides or displays the toolbar.

Settings Menu. The Settings menu allows the selection of setup windows.

Table 2-8: Settings menus

Items	Description
Channel Group	Displays the Channel Group window which creates/edits groups and assigns logic and physical channels.
Blocks	Displays the Blocks window which creates and edits blocks.
Data-Listing	Displays the Data-Listing window which creates and edits patterns.
Data-Waveform	Displays the Data-Waveform window which creates and edits patterns.
Level	Displays the Level window which sets the output level.
Timing	Displays the Timing window which sets the clock frequency, delay, long delay on/off.
Time Base	Displays the Time Base window which specifies the clock source, trigger source, and event signals.
Sequence	Displays the Sequence window which creates sequence. It also sets the jump mode and jump timing.
Subsequence	Displays the Subsequence window which creates subsequence.
Jitter Generation	Displays the Jitter Generation window which sets the jitter generation parameters.
DC Output	Displays the DC Output window which sets the DC Output parameter.

System Menu. The System menu contains the items related to the data timing generator system.

Table 2-9: System menus

Items	Description
Run	Starts the signal output. This is the same as pushing the RUN button on the front panel.
Stop	Stops the signal output. This is the same as pushing the RUN button on the front panel during the signal output is being performed.
Data Generator	Switches to Data Generator mode. This has the same effect as pushing the front panel PULSE GEN button or clicking Data Gen/ Pulse Gen button on status bar.
Pulse Generator	Switches to Pulse Generator mode. This has the same effect as pushing the front panel PULSE GEN button or clicking Data Gen/ Pulse Gen button of status bar.
Remote Control...	Makes the settings for remote control through GPIB.

Table 2-9: System menus (cont.)

Items	Description
Diagnostics...	Executes the internal hardware check.
LCD Panel Check...	Executes the LCD operation check.
Front Panel Key Check...	Verifies if the front panel controls are operational. Pressing a key or knob on the front panel to display its name and change the color of the key or knob on the screen. Pressing ENTER key twice to exit the front panel key check.
Skew Calibration...	Executes the skew calibration.
Level Calibration...	Executes the level calibration.
Service Password...	Displays the password input dialog box. This menu is provided for service engineer. Refer to Service Password on page 6-73.

Options Menu. The Options menu contains the Preference item that is used for the instrument setup.

Table 2-10: Options menu

Items	Description
Preference...	Startup: You can select a startup state for either default settings or the most recent settings you used. LCD Brightness: Adjusts the brightness of the display screen of the data timing generator.

Help Menu. The Help menu contains help topics and password input box.

Table 2-11: Help menus

Items	Description
Help Topics...	Opens the DTG5000 series online help screen.
Help on Window...	Opens the help screen for currently displayed window.
Specifications...	Displays the DTG5000 series specifications.
Contacting Tektronix...	Displays the contact information for product support.
About DTG...	Displays the instrument software version and copyright information.

Toolbar. The toolbar contains the shortcut buttons for the data timing generator. Accessing the toolbar requires a mouse. Two types of toolbars are provided; the common toolbar to all windows and a specific toolbar for several windows. See Figure 2-8.

To hide or display the toolbar on the screen, select **Toolbar** from the **View** menu.

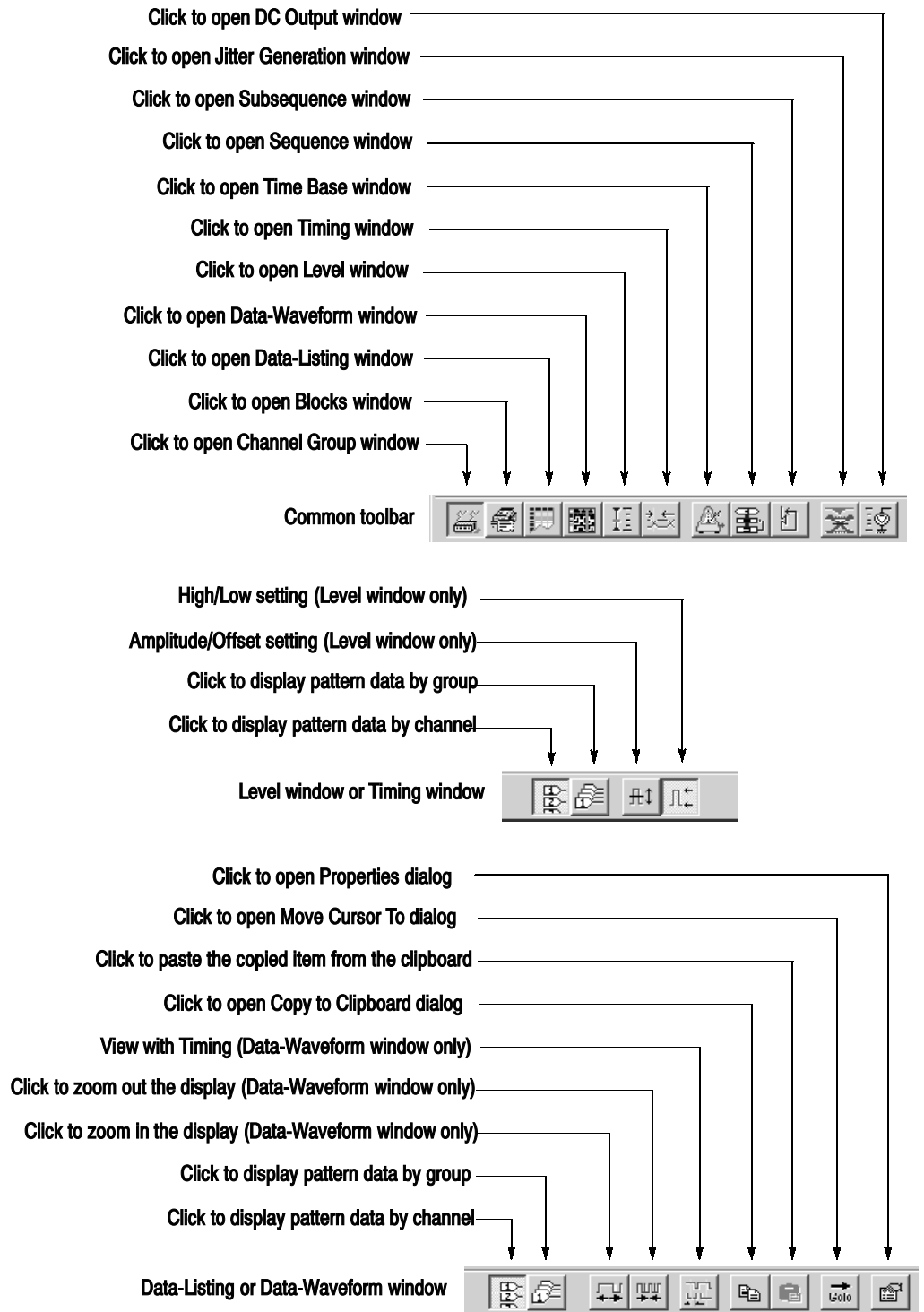

Figure 2-8: Toolbar

Status Bar. The status bar provides useful information about the state of the data timing generator operation or setup.

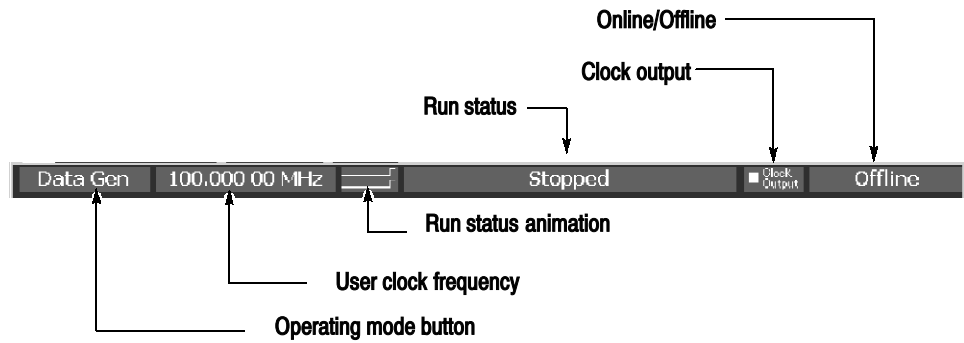

Figure 2-9: Status bar

Table 2-12: Status Bar

Items	Description
Operating mode button	Displays the operating mode (Data Generator mode or Pulse Generator mode). Click to toggle DG and PG modes.
User Clock frequency	Displays the user clock frequency and period set by Timing window. User clock frequency = H/W clock frequency / Vector rate
Run status animation	Displays the sequencer status with animated screen.
Run status	Displays the sequencer status.
Clock Output	Displays the on/off of clock output.
Online/Offline	Displays the DTG5000 software execution mode. Appears only in the offline mode.

Channel Group Window

The Channel Group window enables you to group the logical channels and associate the logical channels with physical channels. The physical channels represent the hardware channels which are actually installed in the data timing generator. See Figure 2-10.

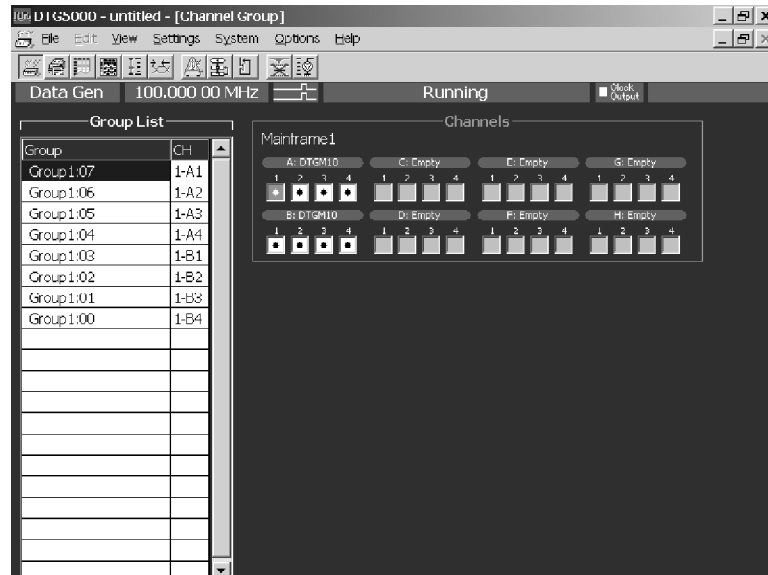

Figure 2-10: Channel Group window

- **Group List.** This list shows the logical channels comprising each of the groups and the physical channels associated with the logical channels. By default, the list shows the installed hardware channels (online mode) or logical channels set by the DTG5000 Configuration Utility (offline mode). The channels are grouped by eight channels.
- **Channels.** This list shows the actual installed channels (online mode) or physical channels set by the DTG5000 Configuration Utility (offline mode).

Edit menu. This menu contains group editing and channel assignment commands.

Table 2-13: Edit menus for Channel Group window

Items	Description
New Group...	Creates a new group.
Delete Group	Deletes the group you selected.
Delete All Group	Deletes all the groups.

Table 2-13: Edit menus for Channel Group window (cont.)

Items	Description
Rename/ Resize Group...	Renames the group you selected. Changes the number of channels included in the group.
Auto Assign	Assigns physical channels installed in the data timing generator to the logical channels in order.
De-assign All	Clears all the logical and physical channels assignments.
De-assign	Clears the physical channels assigned to the logical channels you selected.
Preset	
8 Channels per Group	Defines the number of channels per group as 8.
1 Channel per Group	Defines the number of channels per group as 1.
All Channels in One Group	Collects all the channels in a single group.

Blocks Window

The basic data pattern is called “block” in the Data Generator mode. In the Blocks window, you can create a new block, rename it, and resize or delete the block.

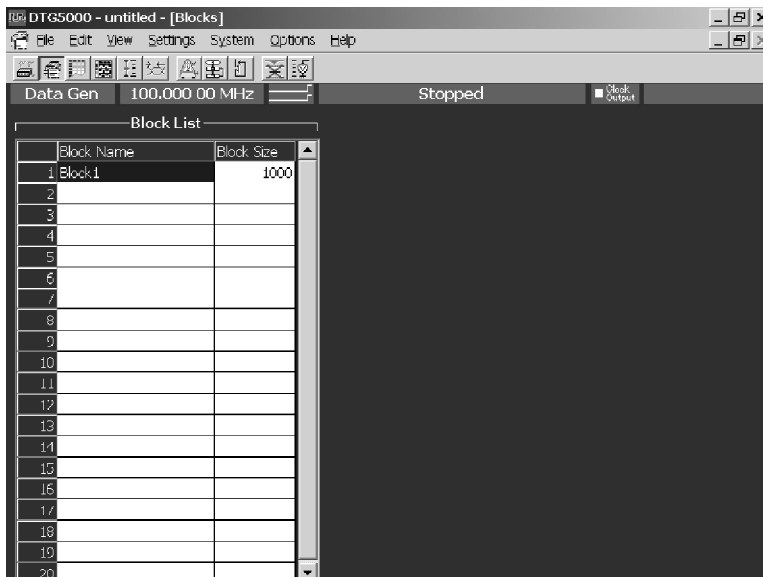

Figure 2-11: Blocks window

Table 2-14 shows the setup items in the Blocks window.

Table 2-14: Setup items for Blocks window

Items	Description
Block Name	Specifies the block name. Accepts up to 32 characters and 8,000 blocks.
Block Size	Specifies the block size. Up to 32,000,000 (DTG5274) or up to 8,000,000 (DTG5078).

Edit Menu. This menu contains commands that are used to delete blocks or move them to the edit windows.

Table 2-15: Edit menus for Blocks window

Items	Description
Edit	Sets Block Name or Block Size.
View Listing	Views the content of the selected block in the Data-Listing window, where you can edit its content.
View Waveform	Views the content of the selected block in the Data-Waveform window, where you can edit its content.
Delete	Deletes the block on the selected line.

Data-Listing Window

In this window, a list of blocks is displayed in tabular form that can be edited. The content edited in the Data-Listing window is the same as that of Data-Waveform window. The only difference is their display format. The Data-Listing window displays the data as tabular form, while the Data-Waveform window displays the data graphically. Because the data to be edited is identical, the edited data in either of the windows is automatically reflected in the other.

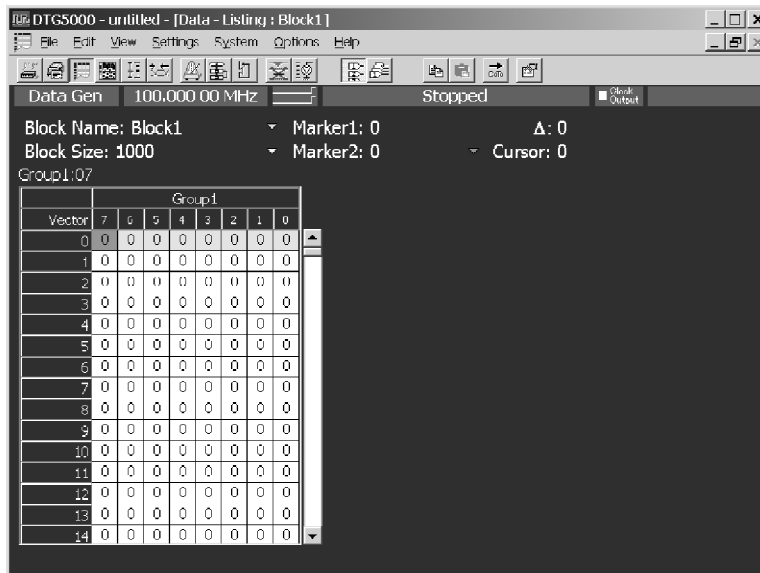

Figure 2-12: Data-Listing window

A table which indicates the blocks, a cursor, and a marker which specifies the edit range are displayed in the window.

The table is displayed by channel or by group. In the group mode, you can select one of various Radix display formats.

There are two methods to edit a pattern. Directly enter the numeric value to each cell or use the Edit menu.

Sometimes the editing requires specifying the edit range. You can specify all of the current channels and groups, the channels and groups between markers, or the area you specified with cursor.

Edit Menu. This menu contains commands that create or edit various data patterns, move the cursor or marker, switch between the channel and group views, and sort the channels and groups listed.

Table 2-16: Edit menus for Data-Listing window

Items	Description
Undo	Reverses the previous change to the data.
Move Cursor To...	Moves cursor.
Move Marker To...	Moves Marker 1 or Marker 2.
Copy...	Copies the data to the data timing generator clipboard.
Paste	Pastes the data copied in the data timing generator clipboard on the location starting from the active cursor cell.
Invert...	Inverts the data between 0 and 1 in the specified range.
Mirror...	Mirrors the data in the specified range in the vector or bitwise direction.
Shift/Rotate...	Moves the data in the specified range in the bitwise direction. Shift fills the empty cells with 0s. Rotate fills them with the offscreen data.
Fill with One/Zero...	Fills the specified range with 0s or 1s.
Clock Pattern...	Fills the specified range with a clock pattern of 0s and 1s.
Predefined Pattern...	Fills the specified range with a Binary Counter, Johnson Counter, Graycode Counter, Walking Ones, Walking Zeros or Checker Board pattern.
User Defined Pattern	Fills the specified range with a pattern the user entered.
PRBS/PRWS...	Fills the specified range with a pseudo random pattern.
Select Block...	Select another block to be viewed or edited.
Copy to Clipboard...	Copies the data in the specified range as characters to the Windows clipboard.
Paste from Clipboard...	Pastes the data copied in the Windows clipboard as characters to the location starting from the active cursor cell. Also available for importing data from other applications.

Data-Waveform Window

In this window, the blocks are displayed graphically and they can be edited. The content edited in the Data-Waveform window is the same as that of Data-Listing window. The only difference is their display format. The Data-Listing window displays the data as tabular form, while the Data-Waveform window displays the data graphically. Because the data to be edited is identical, the edited data in either of the windows is automatically reflected in the other.

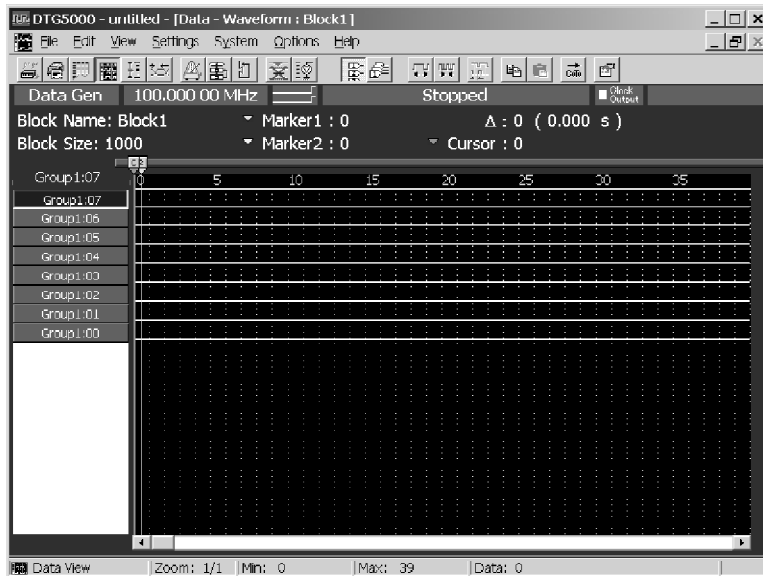

Figure 2-13: Data-Waveform window

Edit Menu. This menu contains the same commands as the Data-Listing window.

Table 2-17: Edit menus for Data-Waveform window

Items	Description
Undo	Reverses the previous change to the data.
Move Cursor To...	Moves cursor.
Move Marker To...	Moves Marker 1 or Marker 2.
Copy...	Copies the data to the data timing generator clipboard.
Paste	Pastes the data copied in the data timing generator clipboard on the location starting from the active cursor cell.
Invert...	Inverts the data between 0 and 1 in the specified range.
Mirror...	Mirrors the data in the specified range in the vector or bitwise direction.

Table 2-17: Edit menus for Data-Waveform window (cont.)

Items	Description
Shift/Rotate...	Moves the data in the specified range in the bitwise direction. Shift fills the empty cells with 0s. Rotate fills them with the offscreen data.
Fill with One/Zero...	Fills the specified range with 0s or 1s.
Clock Pattern...	Fills the specified range with a clock pattern of 0s and 1s.
Predefined Pattern...	Fills the specified range with a Binary Counter, Johnson Counter, Graycode Counter, Walking Ones, Walking Zeros or Checker Board pattern.
User Defined Pattern	Fills the specified range with a pattern the user entered.
PRBS/PRWS...	Fills the specified range with a pseudo random pattern.
Zoom In	Doubles the size of the view horizontally, with the cursor position as the base.
Zoom Out	Halves the size of the view horizontally, with the cursor position as the base.
Move Up	Moves the current group position up one line. Available only when the table is viewed by group.
Move Down	Moves the current group position down one line. Available only when the table is viewed by group.
Reset Order	Arranges the channels within the current group according to their numbers. Available only when the table is viewed by channel. Has no influence on viewing in the Waveform window.
Properties...	Specifies how data is listed when viewed by group (Magnitude).
Select Block...	Select another block to be viewed or edited.
Copy to Clipboard...	Copies the data in the specified range as text to the Windows clipboard.
Paste from Clipboard...	Pastes the data copied in the Windows clipboard as text to the location starting from the active cursor cell. Also available for importing data from another application.

Level Window In this window, you can set the High/Low levels and the termination voltage or impedance for logic channel. It also allows you to turn the output on or off. The level of output signal can be specified by combining the High/Low levels or Amplitude/Offset values.

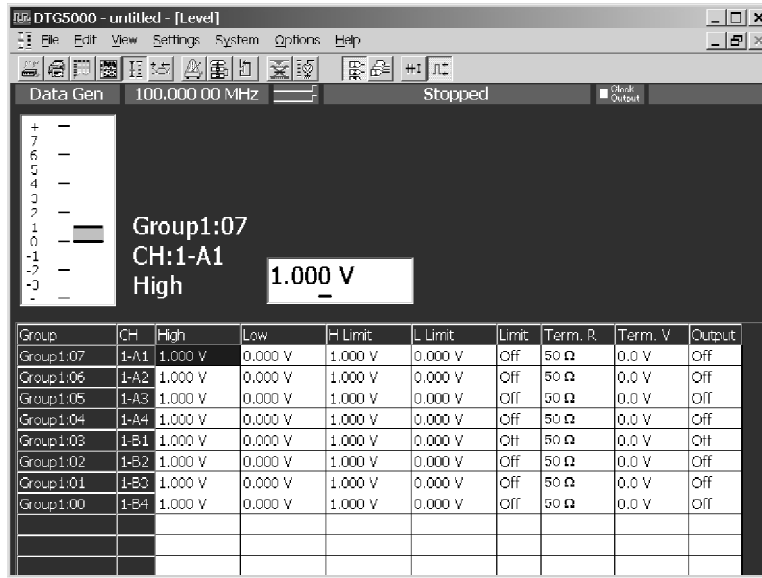

Figure 2-14: Level window

The Level window allows you to setup the items for each channel. See Table 2-18.

Table 2-18: Setup items for Level window

Items	Description
High	Sets the High level value.
Low	Sets the Low level value.
H Limit	Sets the High level limit value.
L Limit	Sets the Low level limit value.
Limit	Turns on or off the High/Low limit feature.
Term R	Sets the termination impedance of the destination of the output signal.
Term V	Sets the termination voltage of the destination of the output signal.
Output	Turns the output to on or off.

Edit Menu. The Edit menu of the Level window allows you to set the items below. You can turn on or off Limit and Output, or you can specify Open to Termination Impedance (Term.R), depending on the selection. The table 2-19 lists the common setting items regardless of the selection:

Table 2-19: Edit menus for Level window

Items	Description
Predefined Level...	Provides the following levels: TTL (into open), TTL (into 50 Ω to GND), CMOS 5 V (into open), CMOS 3.3 V (into open), ECL (into 50 Ω to -2 V), PECL (into 50 Ω to 3 V), PECL (into 50 Ω to 5 V), LVPECL (into 50 Ω to 1.3 V), LVPECL (into 50 Ω to 3.3 V), LVDS (into 100 Ω differential), TMDS (into 50 Ω to 3.3 V), RSL (into 28 Ω to 1.8 V), CML (into 50 Ω to GND)
High/Low	Specifies High and Low for the level setting.
Amplitude/Offset	Specifies Amplitude and Offset for the level setting.
Apply to Channels in the Same group	Applies the currently selected settings to all channels within the group.
Apply to All Channels	Applies the currently selected settings to all channels.

Timing Window

In this window you can set the pattern format and time base parameters such as the frequency, delay, pulse width and slew rate. Some of the set up parameters are different in Data Generator mode and Pulse Generator mode.

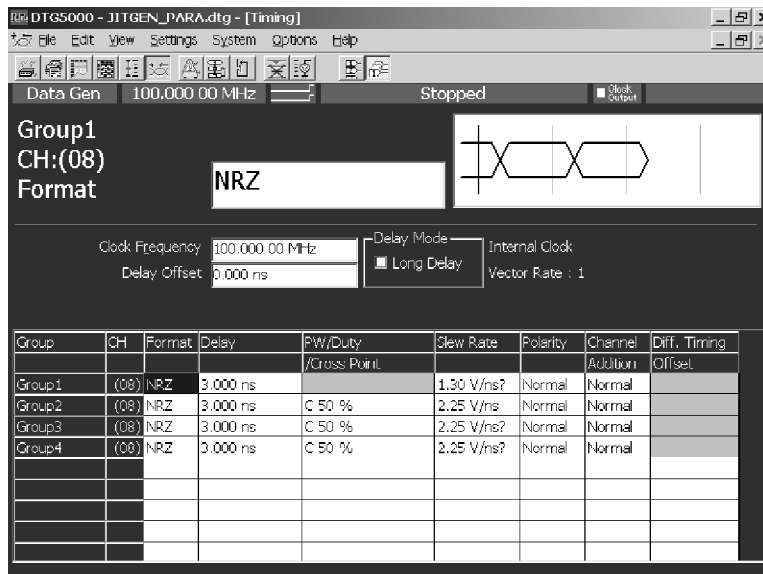

Figure 2-15: Timing window (Data Generator mode)

Table 2-20: Setup items for Timing window

Items	Description
Clock Frequency	Sets the clock frequency of the data timing generator system. Either Frequency or Period is available for this setting.
Delay Offset	Sets the offset amount of the delay time.
Delay Mode	Selects Long Delay on/off.
Clock Range	Sets the clock range when Long Delay is on.
Vector Rate	Vector rate (viewed only)
Internal Clock, PLL Input, External Reference Input, External Clock Input	Shows current clock source or the frequency of the external clock signal.
Group	Shows the group name when View by Group is selected. Alternatively shows both the group name and channel number when View by Channel is selected.
CH	Shows the physical channel assigned in the Channel Group window.

Table 2-20: Setup items for Timing window (cont.)

Items	Description
Format	Selects NRZ, RZ or R1 for the pattern format.
Delay	Sets the lead delay (time or percentage).
PW/Duty/Cross Point	Sets the pulse width or the duty when the format is set to RZ or R1. Any of Duty(%), Pulse Width(s) or Trail Delay(s) is available for this setting. If the format is set to NRZ and the DTGM30 output module is installed, you can change the cross point location by shifting the rising or falling edge.
Slew Rate	Sets the slew rate (V/ns). Unavailable for any channel to which a DTGM30 channel has been assigned.
Polarity	Selects Normal or Invert for the polarity of the pattern.
Channel Addition	Sets the channel addition. Selects from Normal, XOR, or AND. If the odd CH is assigned to physical channel, Normal and XOR can be selected. If the even CH is assigned to physical channel, Normal and AND can be selected.
Diff. Timing Offset	Shifts timing for only inverted side of differential output. Sets differential timing offset on/off and timing volume.

Edit Menu. The Edit menu of the Timing window contains the commands common to the whole table and the commands available for the currently selected item.

Table 2-21: Edit menus for Timing window

Items	Description
Apply to Channels in the Same Group	Sets the currently selected settings for all channels within the group.
Apply to All Channels	Sets the currently selected settings for all channels.
Differential Timing Off-set	Turns on or off the Differential Timing Offset of the currently selected channels or group.
NRZ RZ R1	Selects the data format (when Format is selected).
Lead Delay Phase(%)	Specifies the rising position of a pulse (when Delay is selected).
Duty (%) Pulse Width (s) Trail Delay (s)	Select a setup parameter which specifies the falling position of a pulse (when PW/Duty is selected).
Normal Invert	Sets the polarity (when Polarity is selected).
Normal AND XOR	Sets the channel addition mode (when Channel Addition is selected).

Time Base Window

The Time Base window allows you to specify the clock source, trigger source, or event signal.



Figure 2-16: Time Base window

Table 2-22 shows setup items in the Time Base window.

Table 2-22: Setup items for Time Base window

Items	Description
Clock Source	Selects clock source.
Internal	Use internal clock.
External 10MHz Reference	Use 10 MHz reference clock connected to 10 MHz Reference In.
External PLL Input:	Use external PLL signal connected to Phase Lock In.
External Clock Input:	Use signal connected to External Clock In as an external clock.
Clock Output	Sets the clock output parameters.
Amplitude	Sets clock output signal amplitude.
Offset	Sets offset.
Term.R	Sets termination impedance.
Term.V	Sets termination voltage.
Output On	Specifies on/off of clock output.

Table 2-22: Setup items for Time Base window (cont.)

Items	Description
Trigger	Sets the trigger parameters.
Source	Selects trigger source from internal/external. Specifying Internal allows to set the Interval. Specifying External allows to set the Level, Slope and Impedance.
Slope	Specifies the trigger point (rising edge or falling edge of external trigger signal). Selects either Positive or Negative.
Impedance	Specifies external trigger impedance. (50 Ω or 1 k Ω)
Interval	Specifies internal trigger interval.
Level	Specifies external trigger level.
Event Input	Sets the event input signal parameters.
Polarity	Specifies rising or falling edge. (Normal or Invert)
Impedance	Specifies event signal input impedance. (50 Ω or 1 k Ω)
Threshold	Specifies event signal input threshold level.

There is no Edit menu on this window.

Sequence Window

A sequence is a data structure of one or more combined blocks, where the data timing generator can output more complex pattern. The Sequence window allows you to define the blocks, the output sequence, the jumping method, and other sequence conditions.

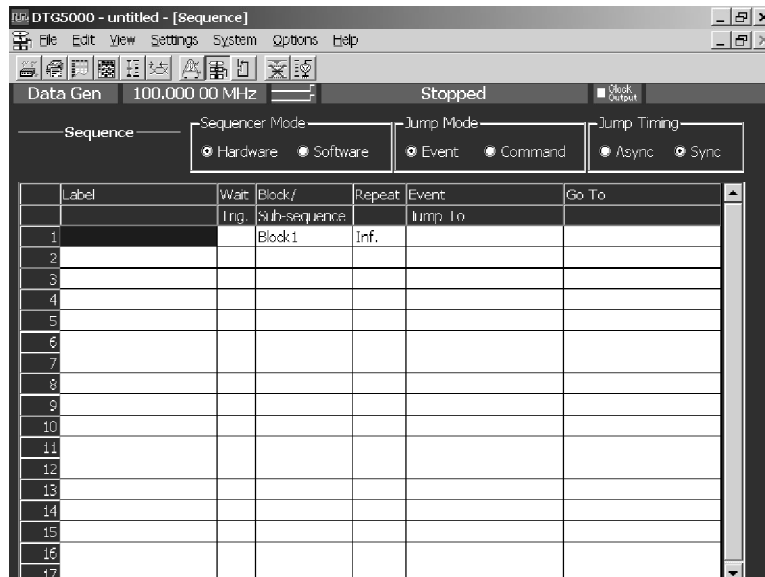

Figure 2-17: Sequence window

Table 2-23 shows setup items in the Sequence window.

Table 2-23: Setup items for Sequence window

Items	Description
Label	Sets the line name. Accepts up to 16 characters for each label name and defines up to 8,000 lines. Labels defined may be used as destinations of Event Jump To and/or Go To.
Wait. Trig.	Specifies whether the system waits for triggering before outputting the line. Selects On or Off (blank).
Block/Subsequence	Specifies the name of the block or subsequence to be output on the line. Accepts up to 32 characters for each name.
Repeat	Specifies the number of repetitions of the block or subsequence. Accepts an integer from 1 to 65,536 or Infinite.
Event Jump To	Specifies the label of the line to which control jumps when an event occurs while the contents of the current line are being output. If the cell is left blank, control will not jump.

Table 2-23: Setup items for Sequence window (cont.)

Items	Description
Go To	Specifies the label of the line to which control jumps unconditionally after the contents of the current line are output. If the cell is left blank, control goes to the next line.
Sequencer Mode	Selects hardware sequence or software sequence.
Jump Mode	Selects event jump (external event signal, front panel button, remote commands) or command jump which is controlled by remote commands.
Jump Timing	Selects ASync which jumps immediately or Sync which does not jump (waits for the completion of current blocks outputs).

Edit Menu. The Edit menu of the Sequence window contains commands not only for the line operations, but also for the currently selected item.

Table 2-24: Edit menus for Sequence window

Items	Description
Edit	Edits Label, block name, subsequence name, or jump destination.
Wait Trigger	Selects On or Off of Wait Trigger (when Wait Trig. is selected).
Infinite	Selects Infinite for Repeat count (when Repeat is selected).
Delete Line	Deletes the line where active cursor is placed.
Insert Line Before	Inserts a blank line immediately above the line where active cursor is placed.
Insert Line After	Inserts a blank line immediately under the line where active cursor is placed.
View Listing	Switches the window to the Data-Listing window, where shows selected block data. This menu selection is available when the block name is selected.
View Waveform	Switches the window to the Data-Waveform window, where shows selected block data. This menu selection is available when the block name is selected.
View Subsequence Definition	Switches the current window to Subsequence window, where shows selected subsequences contents. This menu selection is available when the subsequence is selected.

Subsequence Window

A subsequence is a suite of the blocks used in the main sequence. In this window you can define the subsequences that are used in the sequence.

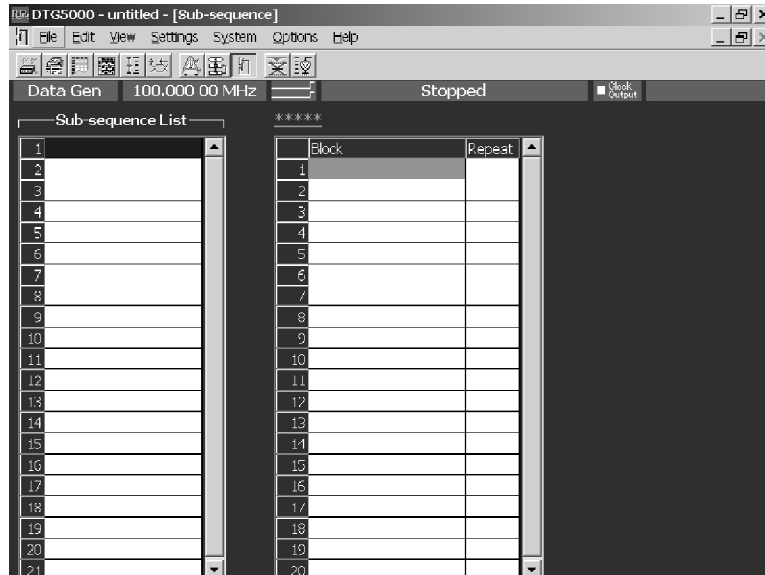

Figure 2-18: Subsequence window

Subsequence List (left) contains the names of the currently defined subsequences. You can define up to 50 subsequences.

The right table lists the contents of the subsequence selected. For each subsequence, you can define up to 256 lines.

Table 2-25: Setup items for Subsequence window

Items	Description
Block	Specifies the name of the block to be output on the line. Accepts up to 32 characters for each block name.
Repeat	Specifies the number of repetitions of the block. Accepts an integer from 1 to 65,536, but does not accept Infinite.

Edit Menu. The Edit menu of the Subsequence window contains commands not only for the line operations, but also for the currently selected item.

Table 2-26: Edit menus for Subsequence window

Items	Description
Delete Line	Deletes the line where active cursor is placed.
Insert Line Before	Inserts a blank line immediately above the line where active cursor is placed.
Insert Line After	Inserts a blank line immediately under the line where active cursor is placed.
View Listing	Switches the window to the Data-Listing window, where shows selected blocks data. This menu selection is available when the block name is selected.
View Waveform	Switches the window to the Data-Waveform window, where shows selected blocks data. This menu selection is available when the block name is selected.

Jitter Generation Window

In this window you can set the parameters required for jitter generation. The jitter generation is available only for Slot A, CH1.

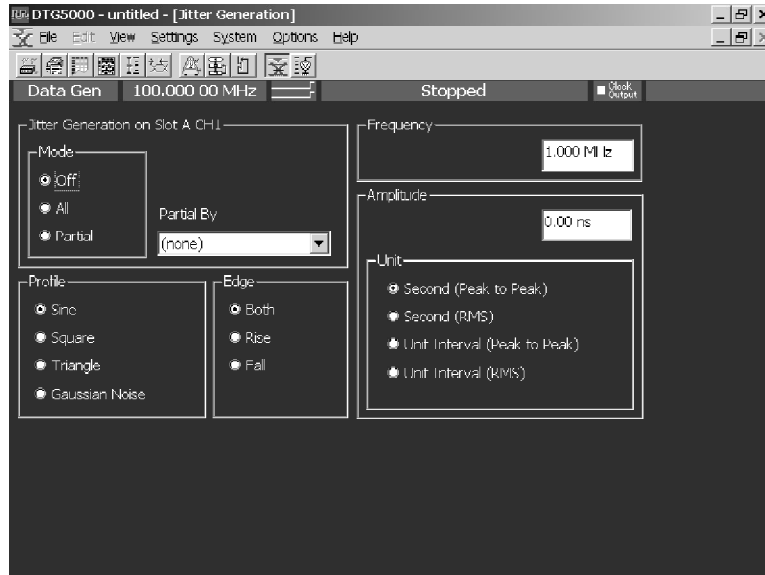

Figure 2-19: Jitter Generation window

Table 2-27: Setup items for Jitter Generation window

Items	Description
Jitter Generation on Slot A CH1	<p>Off: Turns off jitter generation.</p> <p>All: Applies a jitter to the whole pattern of Slot A Ch1.</p> <p>Partial: Partially applies a jitter to the pattern of Slot A Ch1. The partial jitter is generated at the point logical channel set to 1. You can select the logical channel using Partial By field.</p>
Profile	Selects jitter profile.
Edge	Specifies the edge to apply a jitter.
Frequency	Sets the repetitive frequency of the profile.
Amplitude	Set the profile amplitude and jitter width. For the unit, you may select either s (seconds) or UI (Unit Interval, 1 clock period of data timing generator). Specifies peak-to-peak or RMS values.

There is no Edit menu on this window.

DC Output Window

In this window you can set the parameters of the DC output located at the front right of the data timing generator. Eight channel DC outputs are equipped with a mainframe. While the system configuration is in Master-Slave mode, the master machine can control the DC Outputs of all the slave machines.

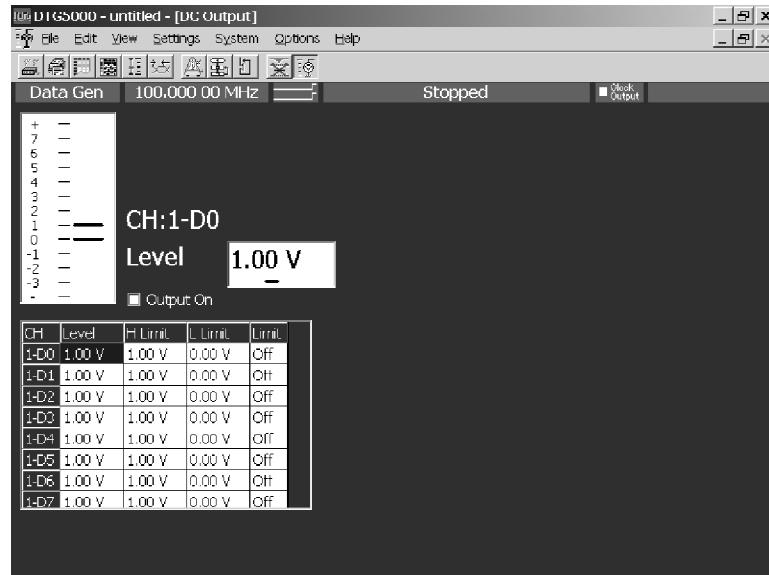

Figure 2-20: DC Output window

The DC Output window allows you to set the following for each channel. See Table 2-28.

Table 2-28: Setup items for DC Output window

Items	Description
Level	Sets the DC level value.
H Limit	Sets the maximum value of DC level setting range.
L Limit	Sets the minimum value of DC level setting range.
Limit	Turns on or off the High/Low limit function.
Output On	Powers the output on or off.

Edit Menu. Provides the predefined levels.

Table 2-29: Edit menus for DC output window

Items		Description
TTL	High	Sets 2.50 V.
	Low	Sets 0.00 V.
CMOS 5 V	High	Sets 5.00 V.
	Low	Sets 0.00 V.
CMOS 3.3 V	High	Sets 3.30 V.
	Low	Sets 0.00 V.
ECL	High	Sets -0.90 V.
	Low	Sets - 1.70 V.
PECL	High	Sets 4.10 V.
	Low	Sets 3.30 V.
LVPECL	High	Sets 4.10 V.
	Low	Sets 1.60 V.
LVDS	High	Sets 1.40 V.
	Low	Sets 1.00 V.
TMDS	High	Sets 3.30 V.
	Low	Sets 2.80 V.
RSL	High	Sets 1.80 V.
	Low	Sets 1.00 V.
CML	High	Sets 0.00 V.
	Low	Sets - 0.41 V.

Using the Menu System

This section describes the basic operation of the data timing generator using the front panel keys, buttons and knob.

Menu System

Pushing the front panel **MENU** button displays the last menu you selected on the menu bar.

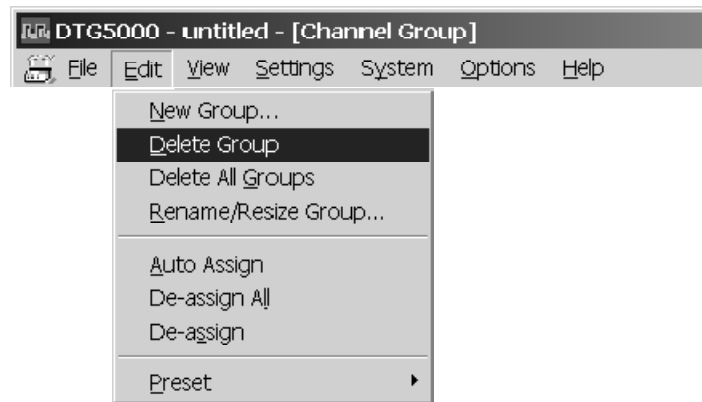

Figure 2-21: Menu selection

- To navigate through a pull-down menu list, use the Up or Down arrow key. To show a submenu (▶), use the Right arrow key. You can also use the knob instead of the arrow keys to navigate through a menu list.
- If you press the Left or Right arrow key on a menu item not having any submenu, you can navigate through the menu bar.
- Once you push the **SELECT** button, the menu is determined.
- To cancel the menu display, push the **MENU** button.
- To use the **ESC** key to cancel the menu display, press the **ESC** key twice. When you press it only once, the menu bar is still active although the display disappears. In this state, you can navigate through the menu bar by pressing the Up, Down, Left, or Right arrow key.

Hint: Pressing the **ALT** key activates the menu bar. Then, you can make a menu selection using the Up, Down, Left and/or Right arrow keys.

Pop-up Menu Items. In the individual data timing generator windows, selecting the setup item and pushing the front panel **SELECT** button displays the pop-up menu item(s) corresponding to the selected item. Refer to Figure 2-23 on page 2-55 for a pop-up menu example.

Using a Window

The data timing generator windows contain various items of information. Input of numeric values such as the output level and clock rate, selection of the trigger source and other settings, creation of the pattern data, and other operations can be performed.

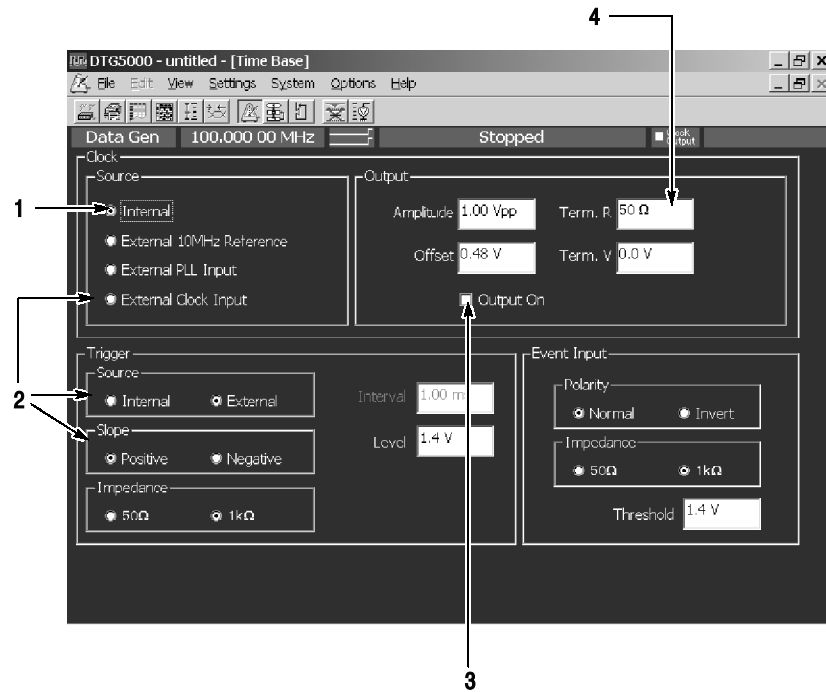

Figure 2-22: Window operation 1: Time Base window

1. To select the parameter with radio buttons such as Clock Source or Trigger Source, use the Up, Down, Left and/or Right arrow key.
2. To navigate through the Clock Source, Output Amplitude, and other similar items, use the **TAB** key. You can navigate through these in the reverse direction by pressing the **SHIFT** and **TAB** keys simultaneously.
3. To place the check sign into a check box such as **Output On**, use the **SPACE** key.
4. Any numeric input box has a unit attribute according to the setting. The unit attribute s is for the time, V for the voltage, Ω for the resistance, or nothing for the count or size. To enter a numeric value, use either numeric keys or the knob. For details, see *Numeric Input* on page 2-60.

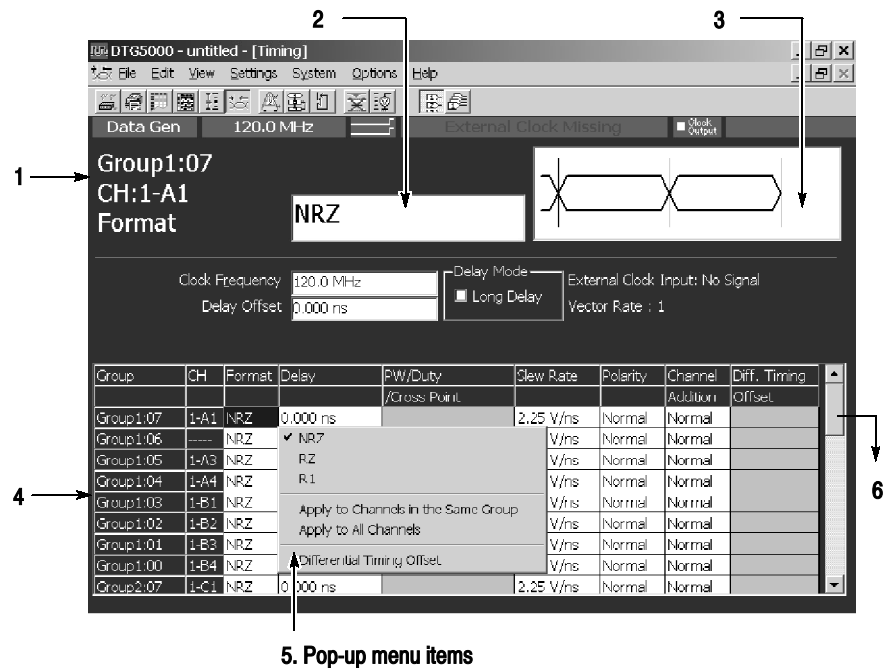

Figure 2-23: Window operation 2: Timing window

A table appears in the Timing, Level and Data-Listing windows. Figure 2-23 shows Timing window.

1. The information area shows the selected parameter information.
2. In the parameter box you can enter numeric values or characters.
3. A Pattern Display Box that contains a pattern corresponding to the Format or Delay appears.
4. The parameter area at the lower part of the window lists the setting parameters such as Frequency or Delay. The parameters that can be set for each of the channels are listed in tabular form.
5. A pop-up menu appears when an item is selected in the table, pushing the **SELECT** button or right-clicking the mouse on the selected item displays the menu items corresponding to the item.

For Format, Polarity, or Mode selections, first display the pop-up menu, then select the parameter.

6. The scroll bar is activated when the mouse is attached. Scroll the cursor to display the hidden tables outside the display area.
 - To navigate through items in the parameter area, use the **TAB** key.

- To move the cursor through items within the table, use the Up, Down, Left or Right arrow key.
- In Polarity, you can toggle between its two options by pressing the **SPACE** or **ENTER** key.
- For numeric parameters such as Delay or PW/Duty, enter numeric values using numeric keys or the knob. See *Numeric Input* on page 2-60.
- You can select either **View By Channel** or **View By Group** window display. You can toggle between the two by using View menu.
- You can select On or Off of Limit or Output parameter by pressing the **SPACE** or **ENTER** key in the Level window.

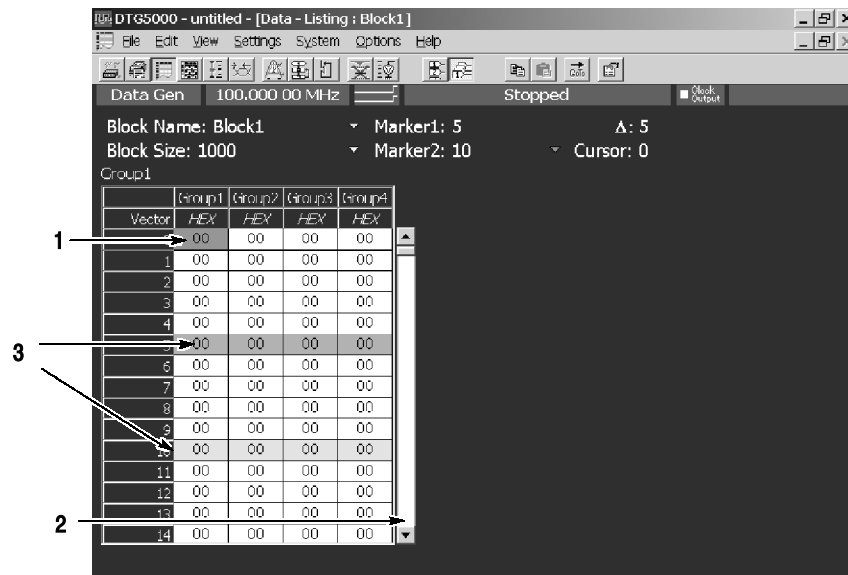

Figure 2-24: Window operation 3: Data-Listing window

In the Data-Listing and Data-Waveform windows you can create or edit data. The edit window allows you to use the cursor and markers to define the edit range.

1. You can move the cursor in the vector or bitwise direction by using the Up, Down, Left, or Right arrow key.

To specify the region, use the Up, Down, Left, and/or Right arrow keys while pressing the **SHIFT** key. Specifying the region is available within the same group. You can not define the region beyond the group.

2. The scroll bar is activated when the mouse is attached. Scroll the cursor to display the hidden tables outside the display area.
3. The two markers are used to specify the range. To move the markers, select **Move Marker To...** from the Edit menu to display the Move Marker To dialog. Then, enter the value to each field.

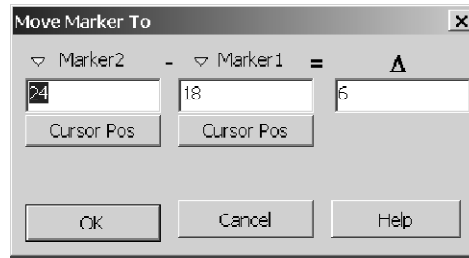

- You cannot move the markers with front panel keys or knob.
- You can move the markers by dragging a mouse in the Data-Waveform window.
- You can select either **View By Channel** or **View By Group**. You can toggle the two displays by using the View menu.

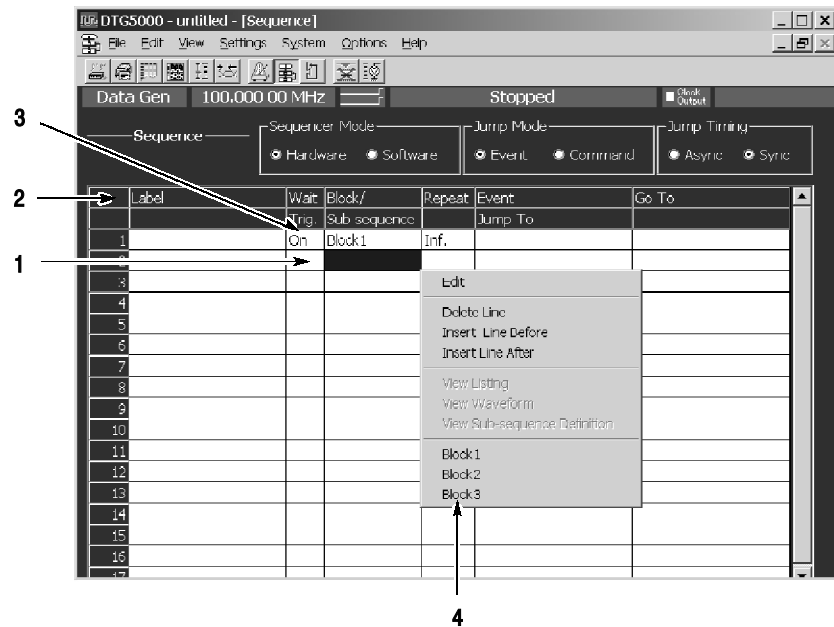

Figure 2-26: Window operation 5: Sequence window

In the Sequence window you can create a sequence by combining blocks and subsequences. This window is also in tabular form like other windows. This window allows you to input characters.

1. To move the active cell through the table, use the Up, Down, Left, and/or Right arrow keys.
2. Any cell in this window accepts characters and digits. To enter characters to Label or Event Jump To column, press the front panel **ALPHA** key to activate the text input mode and then use numeric keys. See *Text Input* on page 2-61.
3. To specify *On* for Wait Trig. or *Inf.* for the Repeat, use the **Edit** menu. You can also use the **SELECT** button to display the pop-up menu. See page 2-53 for information on how to use the data timing generator menu system.
4. The blocks and subsequences already defined in the Blocks or Subsequence window are listed in the **Edit** menu, which allows you to specify the block or subsequence in the Block/Subsequence column. You can also specify the the block or subsequence by using the **SELECT** button and pop-up menu.

Numeric Input

Any numeric input box has a unit attribute according to the setting. The unit attribute **s** is for the time, **V** for the voltage, **Ω** for the resistance, or nothing for the count or size. The data timing generator recognizes the range of the acceptable parameter values. If you enter a value outside the valid range, the maximum or minimum value will be set automatically. To enter a numeric value, use either numeric keys or the knob.

Using the Numeric Keys. Auxiliary unit keys such as k/m and M/μ are available. For k (kilo-), m (milli-), M (mega-), and their related units, the one suitable for the parameter is selected automatically.

Example 1: Amplitude

- If you press **0**, **.**, **5**, and **ENTER** in this order, 0.5 V is entered.
- If you press **5**, **0**, **0**, and **k/m** in this order, 0.5 V (500 mV) is entered.

Example 2: Term Z

- If you press **5**, **0**, and **ENTER** in this order, 50 Ω is entered.
- If you press **1** and **M/μ** in this order, 1 MΩ is entered.

Using the Knob. If a numeric value is accompanied with an underbar, you can use the knob for editing it. The digit accompanied with an underbar can be edited.

To move the underbar to the target digit to be edited, use the Left and/or Right arrow key under the knob. See Figure 2-3 for the location of the key.

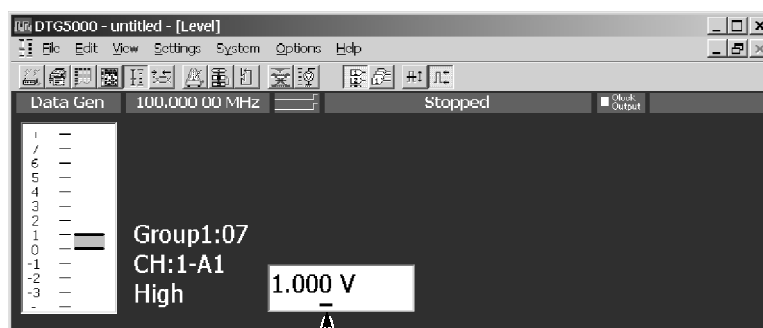

Using the External Keyboard. Numeric keys above the alphabetical letter keys, not those on the numeric keypad, are available on the external keyboard. The k (kilo-), M (mega-), G (giga-), m (milli-), μ (micro-), n (nano-) and p (pico-) keys are available for auxiliary units.

Text Input

To enter text from the front panel, use the **ALPHA** key and numeric keys. Push the ALPHA key to activate the text input mode. In this mode, you can enter characters that are printed above each numeric key. The ALPHA key's LED stays lit if the text input mode is selected.

- Pressing the ALPHA key switches between the numeric and text input modes.
- By pressing a numeric key repeatedly, the characters indicated above the key are displayed in order.

Example: Pressing the **8** key displays **a** at the caret. If you press the 8 key repeatedly, the character changes to b, c, A, B, C and 8 in order.

- When you press another numeric key or the Left or Right arrow key, the character currently displayed is determined and the caret moves. By pressing the **ENTER** key or another numeric key, the character is also determined.
- If you press a key unrelated to text input or the **ESC** key, or use the **ENTER** key to determine the character, the mode automatically changes from text input to numeric input.

File Operations

To save or load the setup file or import data that has been created on another device, use the Windows standard file I/O dialog box. The data timing generator file operations are the same as the general PC file operations. If the mouse is not used, several restrictions are applied to the file operations.

Selecting a file. Do the followings steps to select a file without using a mouse.

1. Press the **TAB** key repeatedly to activate the file view.

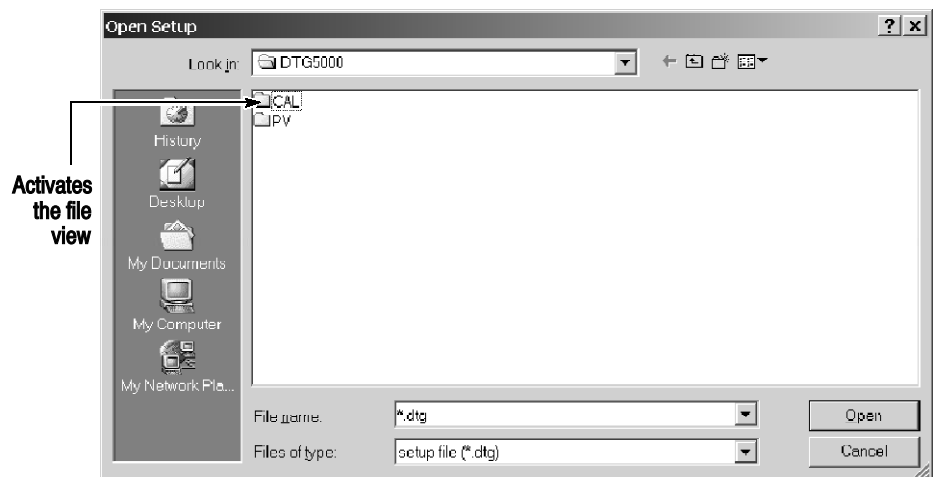

2. Do the following substeps to specify the file within the file view area.

- Use Up or Down arrow key to select the folder.
- Press the **ENTER** key to open the folder.
- Press the **BKSP** key to move the folder hierarchy up.

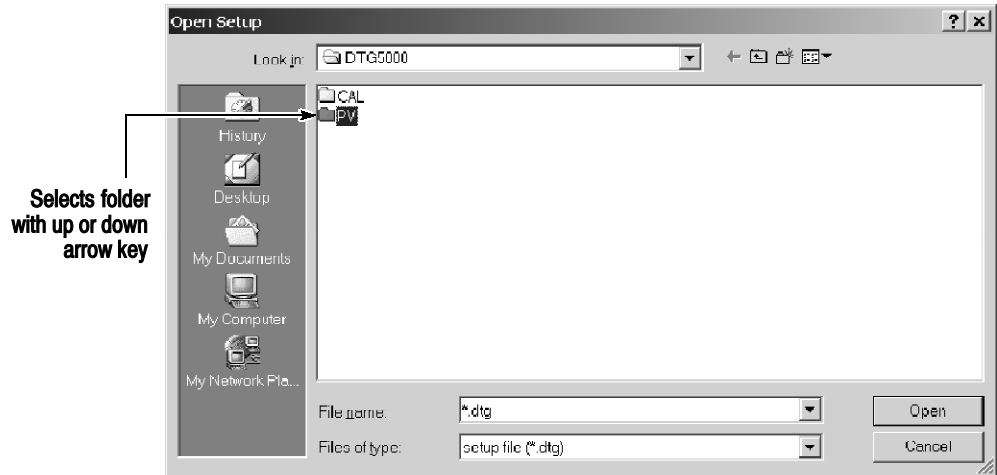

3. Use Up or Down key to specify the file.

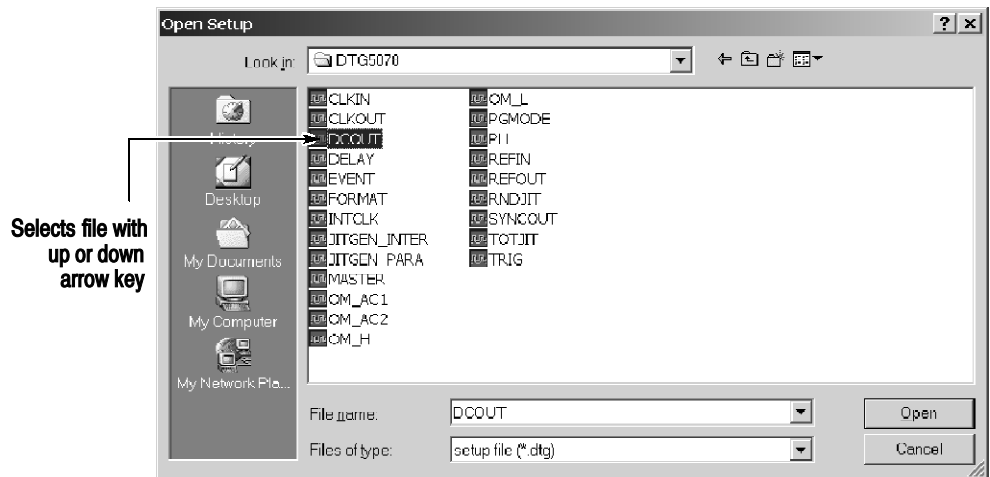

- Press the **ENTER** key to open the file.
- Press the **BKSP** key to return to the upper folder.

Key Operations Table 2-30 summarizes the data timing generator key operations.

Table 2-30: Key operations

Items	Description
MENU button	Displays the last menu you opened on the menu bar.
TAB key	Moves the focus through items in the window. Pressing SHIFT and TAB keys simultaneously reverses the moving direction.
Up/Down/Left/Right arrow keys	Moves the cursor through items on the menu, moves the caret during text input, or selects a radio button.
SHIFT + Up/Down/Left/Right arrow keys	Selects multiple items (Data-Listing/Data-Waveform window), or shifts the current line (SHIFT + Up/Down arrow key only; Timing/Level window).
Knob	Changes a numeric value, moves the cursor through menu items, moves the focus in a table or list, moves the cursor through the Data-Listing or Data-Waveform window, toggles between multiple items for a parameter in the Timing/Level window (NRZ/RZ/R1, On/Off, Normal/Invert, Normal/AND/XOR, etc.), or selects an item from a combo box.
Digit Select arrow keys	Located just below the knob. Moves the cursor through digits while using the knob to enter a numeric value. Refer to page 2-16.
SPACE key	Turns on or off the check sign in a check box, or toggles between two options for a parameter in the Timing or Level window (On/Off, Normal/Invert, etc.).
ALT key	Activates the menu bar.
ALT + ESC key	Switches the active application.
ALT + TAB key	Switches the application (selected with icon display).
ALT + SPACE key	Displays window control menu. You can move/resize/close the window.
ALT + F4	Exits the application. (Available only from the external key board)
ESC key	Cancels text input or a dialog box. Cancels display of a menu opened with the SELECT key. To cancel a menu opened with the MENU key, press ESC key twice.
CTRL + TAB key	Switches the active window in the application.
CTRL + Left/Right arrow key	Moves the cursor between digits during numeric input.
CTRL + Up/Down key	Increments or decrements the value during numeric input.
CTRL + ESC key	Displays the Windows Start menu.
CTRL + ALT + DEL key	Forcibly exits the application. (Available only from the external key board)

Keyboard and Mouse

A USB keyboard and USB mouse are shipped with the data timing generator as standard accessories. Though it is possible to operate the instrument only with front panel controls, attaching the mouse and external keyboard to the data timing generator mainframe makes the operation easier. Read the following topics related to the mouse and external keyboard.

When you set up the Windows operating system or perform the system recovery, the external keyboard and mouse are required.

You can connect or remove the USB devices while the data timing generator powered on.

Mouse.

- Using a mouse allows you to access the toolbar icons, all window buttons and the scroll bar. These cannot be accessed from the data timing generator front panel controls.
- In the data editing windows such as Data-Listing or Data-Waveform, or in the setup windows such as Timing or Level, you can access the area not accessible from the keyboard by dragging, right clicking or left clicking the mouse.

Keyboard.

- The Delete and Back space (BS) functions are assigned to a single key. To use it as BS, press **Fn+Delete**. If you want to use a key as labeled on the key front (such as BS, F1, F2...), press it while holding down the **Fn** key.
- The \diamond key operates as the Windows key.
- You can assign the **Delete** key to the **BS** key using a SW3 DIP switch located on the back. In this case, you can input **Delete** by pressing **Fn+'**. For details of the DIP switches, refer to the underside of the keyboard.
- After you power on the instrument for the first time, you have to set up Windows. Connect the keyboard supplied with the instrument before turning on the power.

NOTE. If you need to perform the system recovery, you must use a PS/2 keyboard and PS/2 mouse.



Theory of Operation

Theory of Operation

This section presents an overview of DTG5000 Series Data Timing Generator hardware, the data structure, and operating modes to allow you to take full advantage the capabilities of the data timing generator.

Interconnect Diagrams

Fig 3-1 and Fig 3-2 show the data timing generator circuitry. This section describes the hardware blocks that provide the background knowledge necessary to use the instrument effectively.

The DTG5000 Series consists of four major electrical sections: Mainframe section, Main board (A50/A54), Output board (A60/A62/A63), and Output Module (DTGM10/M20/M30).

Mainframe Section

The mainframe section consists of Compact PCI CPU Module, A30 Compact PCI Back Plane board, A10 Connector & PCI Interface board, Compact PCI GPIB Card, CD-ROM Module, Front Key & DC Output board, LCD Display and Back Light, FDD, Power Supply, and so on. Mainframe Section consists of the following modules and components.

Compact PCI CPU Module

The Compact PCI CPU Module consists of CPU Celeron (566MHz), DRAM (128M), HDD (20GB), and so on. This module has various connectors on rear panel like VGA, LAN (100 Base-T), Key Board (PS2), Mouse (PS2), USB1.1 (2ea), and COM.

The Compact PCI CPU Module receives commands from the Front Key Board, GPIB interface and Ethernet Interface, controls all H/W in DTG5000 Series by DTG5000 series product software. All Control signals are transmitted via PCI I/F Board.

A30 Compact PCI Back Plane board

The A30 Compact PCI Back Plane board consists of a few decoupling capacitors and LVDS panel control for EMI. This board is satisfied with no popular standards. The back plane has two Compact PCI slots and three local bus slot. This board receives power from the Power Supply module through the A10 Connector & PCI I/F board and sends power to the CPU board. And this board also has the local bus for operating various H/W in DTG5000 Series.

A10 Connector & PCI Interface board

The A10 Connector & PCI Interface board supplies power to all modules and converting a PCI bus to a local bus. This board also handles Power On control, Fan control, and LVDS Panel Control.

Compact PCI GPIB Module

The Compact PCI GPIB Module is a Compact PCI GPIB card (PXI-GPIB) made by National Instruments. Refer to the user manual made by National Instruments for details. This module is controlled by Microsoft Windows 2000 Operating System.

CD-ROM Module

The CD-ROM Module is placed on the A32 CD ROM Extender board with the dedicated flexible circuit board. This CD-ROM Module is controlled by Microsoft Windows 2000 Operating System.

LCD Display & Back light

The LCD Monitor is TFT-type LCD module. This module receives the video signal from the CPU Board via the A10 Connector & PCI Interface board.

A20 Front Key & DC Output Board

The A20 Front Key & DC Output board contains a scan rubber button matrix, LEDs, a rotary encoder and DC Output circuitry. This keyboard interface is compatible with the AWG400/500/600/700 series arbitrary generator.

Power Supply Module

Power Supply Module provides +5V, +3.3V, -4.5V, -2V, +12V, and -8V. This module features the voltage switching regulation and the remote switching mechanism for the ON/STBY switch on the front panel. The Power Supply module sends various regulated voltages to all boards in the mainframe through the A10 Connector and PCI Interface board. The remote switching signal that is generated on the front panel is sent to the CPU Module through the A10 Connector & PCI Interface board. The CPU Module controls the power supply by using the remote control with the Power Supply Module. Software shutdown is also available.

Main Board Section (A50/A54)	The Main board consists of CPU Interface, Pattern Memory, Sequencer, PLL, Trigger Control, Clock Out.
Output Board Section (A60/A62/A63)	The Output board consists of Delay Line and CPU interface.
Output Module Section (DTGM10/M20/M30)	The Output Module consists of Pin-Driver IC, relay, FPGA for signal decoding. Three kinds of Output Module are prepared at this time. The main difference between these Output Modules is that the different pin driver IC is adopted. These three Outputs Modules are called DTGM10, DTGM20, and DTGM30.

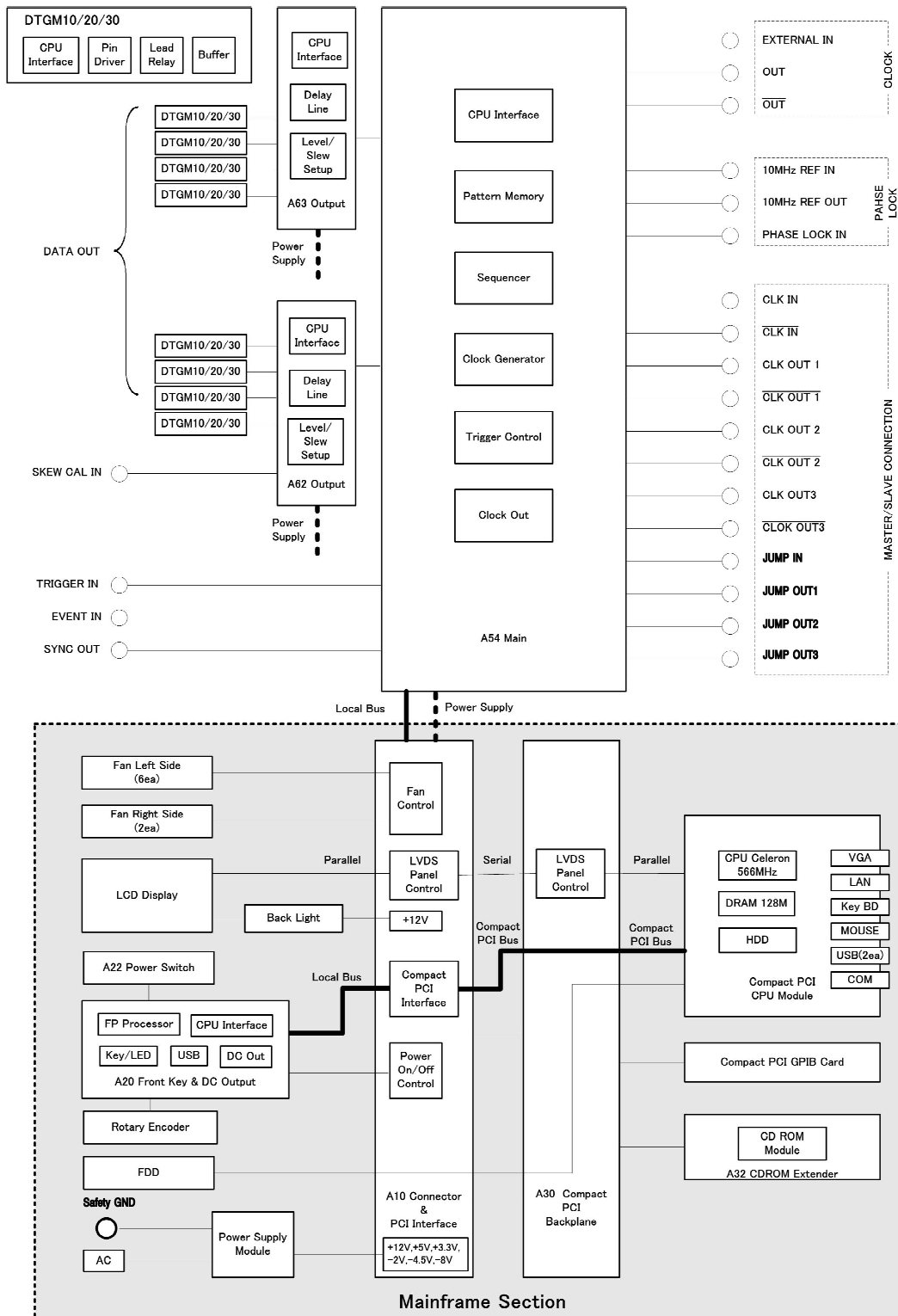

Figure 3-1: DTG5078 interconnection diagram

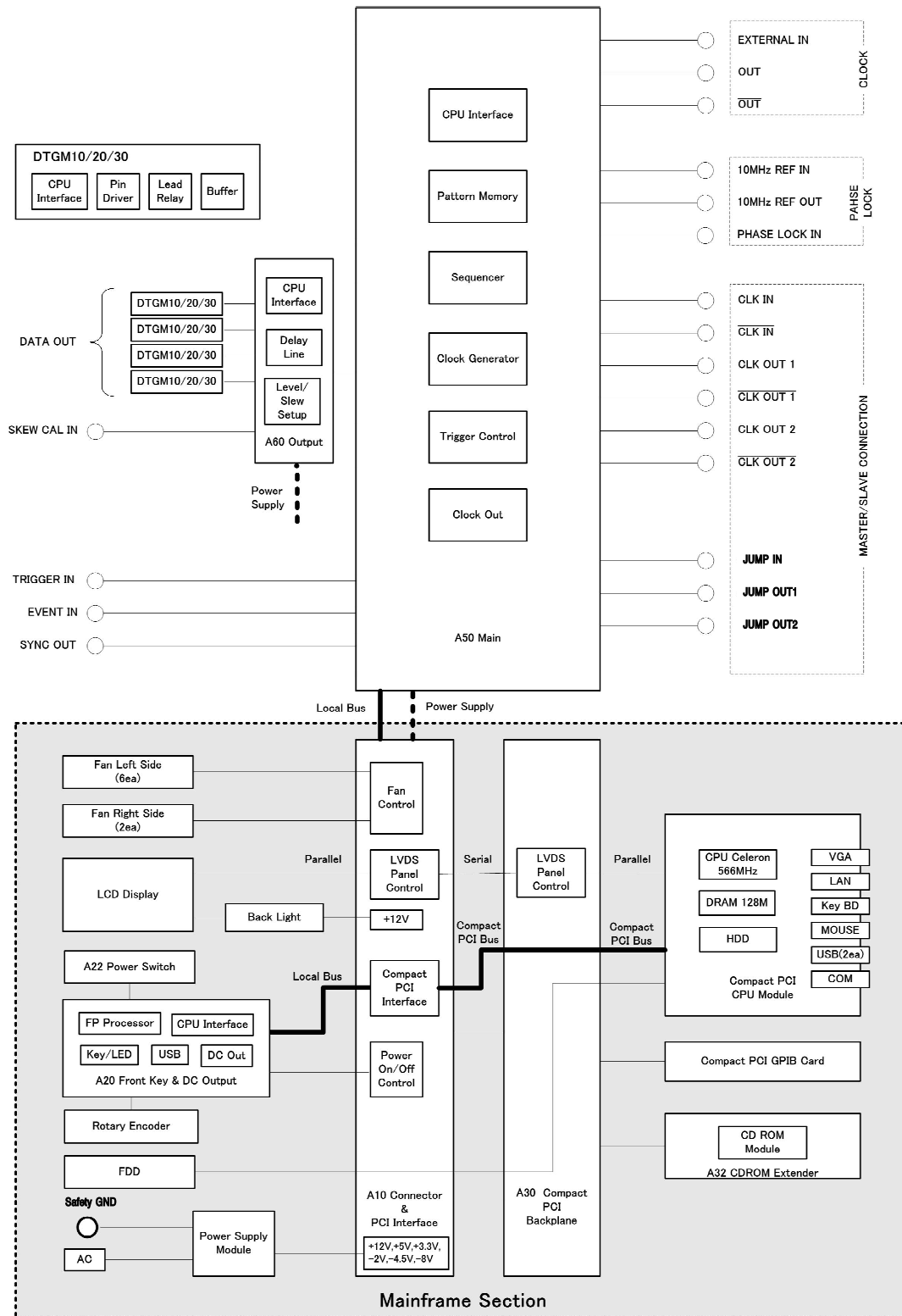

Figure 3-2: DTG5274 Interconnection diagram

Block Diagrams

Figure 3-3 and 3-4 show the main hardware blocks that make up the DTG5000 Series. The DTG5000 series consists of 3 parts, Clock Generator, Pattern Generator, and Timing Control & Output.

Clock Generator

The Clock Generator consists of 10MHz TCXO, External 10MHz Reference, DDS (Direct Digital Synthesis), PLL(Phase Locked Loop), Divider, ASIC including Divider and Trigger Control, and Clock Out. DDS generates clock from 1MHz to 2MHz as a reference signal of an internal 10MHz TCXO or an external 10MHz Reference signal selected by SW1. PLL generates a clock from 500MHz to 1GHz in DTG5078 and from 2GHz to 4GHz in DTG5274. One of DDS output or an external divided Phase Lock In is the reference signal for PLL. SW2 selects one of these signals as a reference source. SW3 selects one of the PLL output or external CLOCK IN as an internal clock. SW4 should be connected to the CLK IN for Master-Slave in the case of Master-Slave Operation. The internal clock generated at this block is sent to several circuits in Pattern generator block. External Clock out can be controlled the amplitude and offset because this has a high speed pin driver.

Pattern Generator

The Pattern Generator consists of Sequence RAM, Sequencer, Pattern RAM, Shift Register, and Latch. Sequence RAM is the memory for the Sequence Program that a user defines. Sequencer outputs arbitrary pattern data according to the Sequence Program written to the Sequence RAN. Sequencer also controls an event jump sequence when the event occurs. Shift Register accelerates Pattern Data supplied from Pattern RAM 15 times or 16 times. This Pattern Data is sent to Timing Control & Output after the data is latched. In case of DTG5274 this latched data is accelerated again 4 times at 4:1 MUX. This Latch and 4:1 MUX are included in the ASIC. Jump In and Jump Out are used for Master-Slave operation. Sync Out is useful as an external trigger signal for the oscilloscope.

Timing Control & Output

Timing Control & Output consists of Delay Line & Pulse Width Control, Jitter Generation Control, Jitter Pattern RAM, Fine Delay Line, Skew Time Detector, Pin Driver and Relay. Delay Line & Pulse Width Control changes the delay time or pulse width of data pattern. This block also generates the intentional jitter according to the pattern written in Jitter Pattern RAM by changing the delay time. Jitter Generation Control drives this intentional jitter. Fine Delay Line produces the delay time resolution of 1ps in DTG5708 and 0.2ps in DTG5274. DTGM10/M20/M30 has the Pin Driver IC and the Relay for opening the outputs.

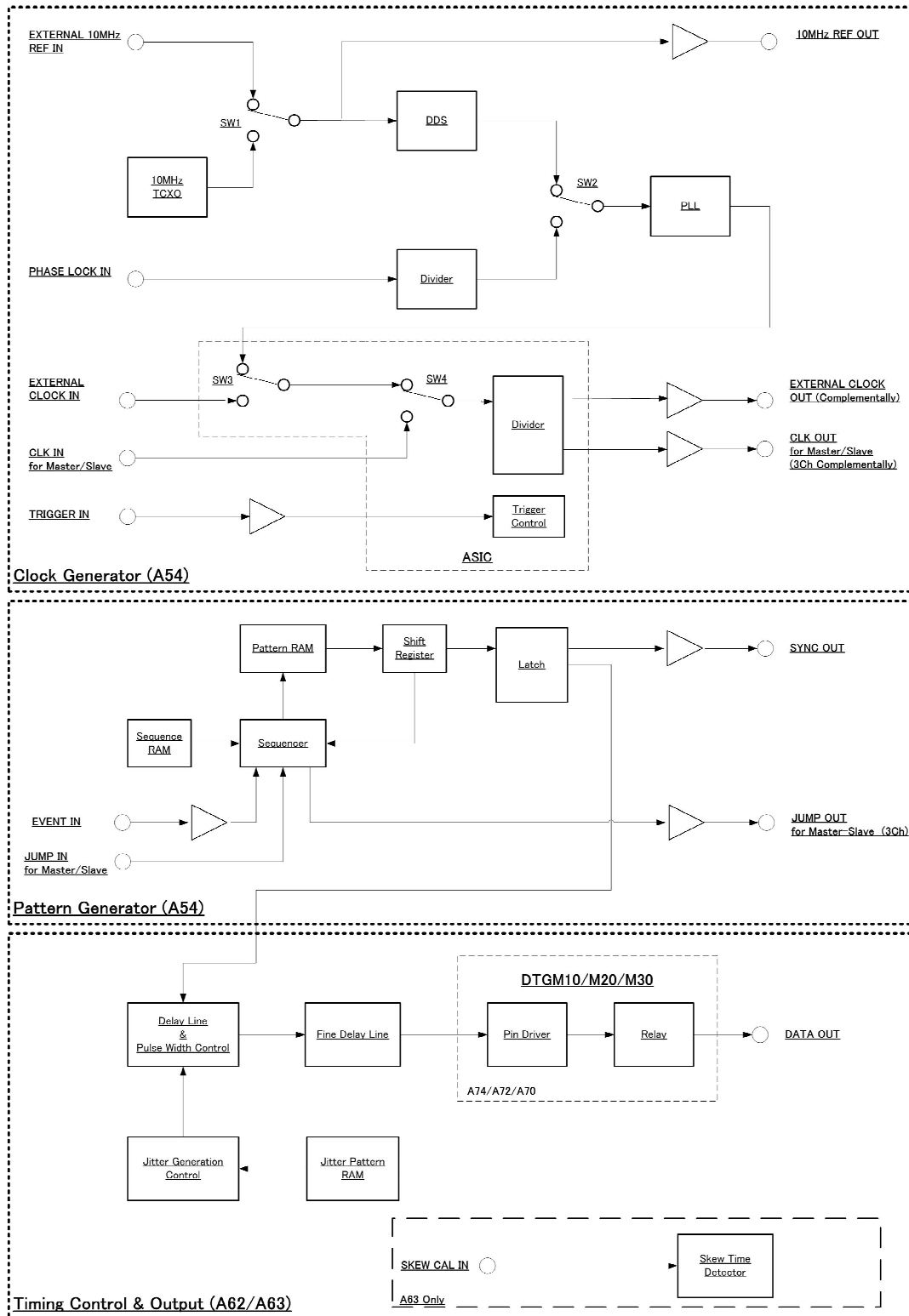

Figure 3-3: DTG5078 block diagram

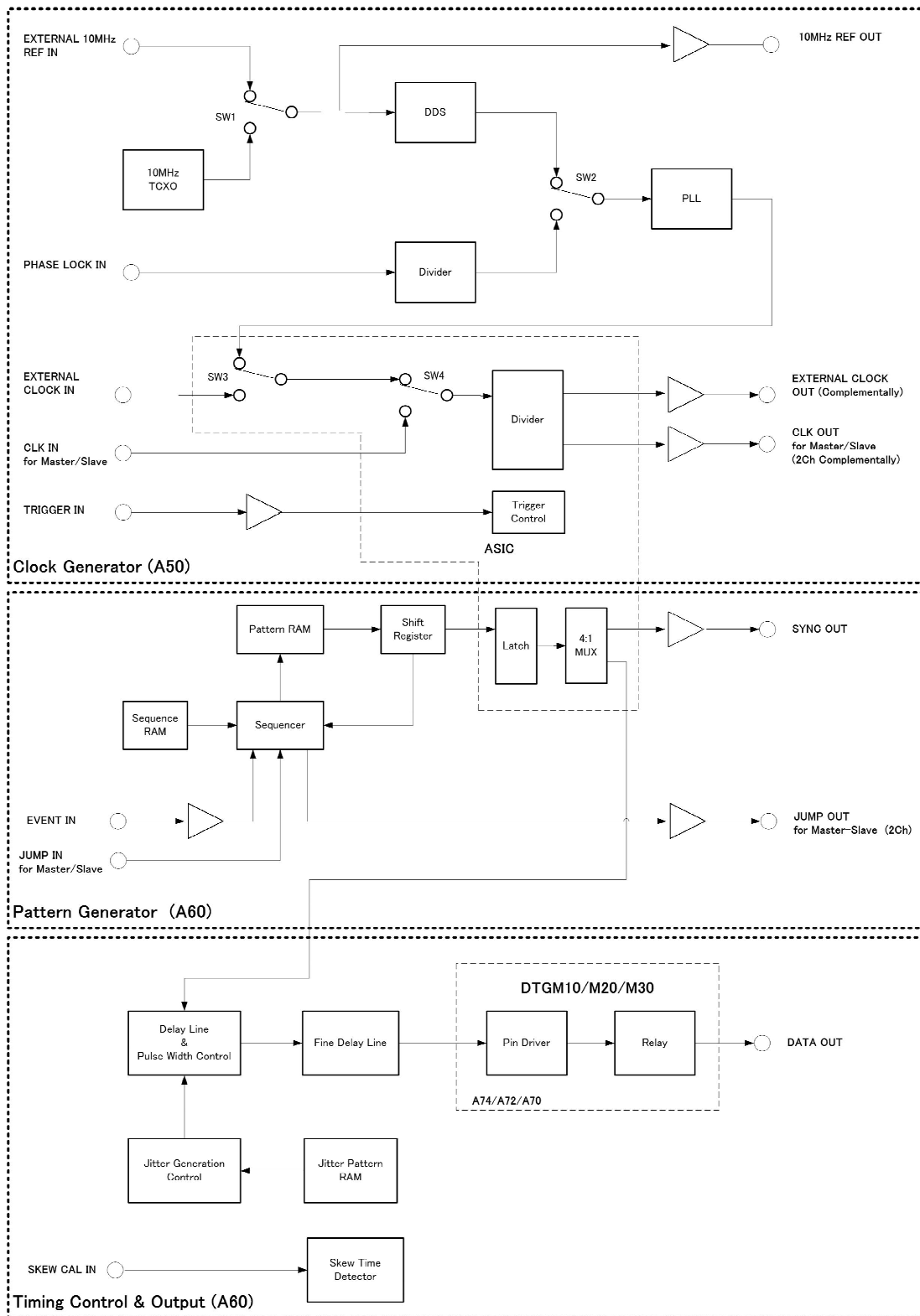

Figure 3-4: DTG5274 block diagram



Performance Verification

Performance Verification

Two types of Performance Verification procedures can be performed on this product: *Self Tests* and *Performance Tests*. You may not need to perform all of these procedures, depending on what you want to accomplish.

- Verify that the DTG5000 Series Data Timing Generator is operating correctly by running the *Self Tests*, which begin on page 4-3.

Advantages: These procedures require minimal time to perform, and test the internal hardware of the DTG5000 Series Data Timing Generator.

- If a more extensive confirmation of performance is desired, complete the self tests, and then do the *Performance Tests* beginning on page 4-10.

Advantages: These procedures add direct checking of warranted specifications. These procedures require suitable test equipment and more time to execute. (Refer to *Equipment Required* on page 4-11).

Conventions in this manual

Throughout these procedures the following conventions apply:

- Each test procedure uses the following general format:

Title of Test

Equipment Required

Prerequisites

Procedure

- Each procedure consists of as many steps, substeps, and subparts as required to do the test. Steps, substeps, and subparts are sequenced as follows:

1. First Step

- a. First Substep

- First Subpart

- Second Subpart

- b. Second Substep

2. Second Step

- Where instructed to use a control in the display or a front-panel button or knob, the name of the control, button or knob appears in boldface type.

Menu Selections

Instructions for menu selection use the following format:

Menu button→**Left or right Allow button** (by using this button, you can move to desired menu category)→**Upper or down Allow button** (by using this button, you can move to desired menu item)→**SELECT or Enter key** (this completes the selection).

You can use a mouse as a pointer, use keyboard shortcuts for quick operation, or use front panel knob instead of sticking to above menu selection format.

User Manual

Reading the *DTG5078 & DTG5274 Data Timing Generators User Manual* is strongly recommended to familiarize the first-time user with instrument controls and features.

Install the Output Modules

Any output modules ordered are shipped separately. For complete instructions on how to install the output modules, refer to the User Manual. (Output modules do not ship preinstalled.)



CAUTION. *Do not install or remove any output modules while the instrument is powered on.*

Always power the instrument down before attempting to remove or install any output module.

Self Tests

There are two types of tests in this section that provide a quick way to confirm basic functionality and proper adjustment:

- Diagnostics
- Calibration (You must perform this calibration before the performance tests.)

These procedures use internal diagnostics to verify that the instrument passes the internal circuit tests, and calibration routines to check and adjust the instrument internal calibration constants.

NOTE. To perform the Self Tests, at least one output module (DTGM10, DTGM20, or DTGM30) must be installed in the DTG5000 series Data Timing Generator mainframe. You can select any slot when you perform the tests even though the descriptions below are assuming the Slot A is used.

Diagnostics

This procedure uses internal routines to verify that the instrument is operating correctly. No test equipment or hookups are required.

The instrument automatically performs the internal diagnostics when powered on; you can also run the internal diagnostics using the menu selections described in this procedure. The difference between these two methods of initiating the diagnostics is that the menu method does a more detailed memory check than the power-on method.

Do the following steps to run the internal routines that confirm basic functionality and proper adjustment.

Equipment required	None
Prerequisites	First, at least one output module must be installed properly in the mainframe. Second, power on the instrument and allow a twenty-minute warmup before doing this procedure.

1. Set up the instrument:

- Confirm that there is no output being performed by verifying that the **RUN** button indicator is not on. If the indicator is on, push the **RUN** button to turn it off.

- Verify that the output module LEDs are not on. If any output module LEDs are on, push the **ALL OUTPUTS ON/OFF** button to turn the LEDs off.
2. Internal diagnostics: Perform these substeps to verify internal diagnostics.
- a. Display the Diagnostics dialog:
 - From the application menu bar, select **System**, and then select **Diagnostics....** The following dialog appears if you have changed the settings.

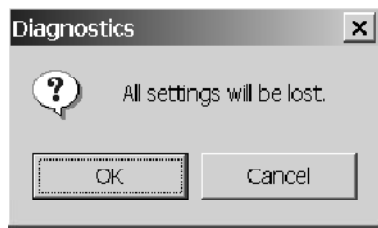

- Select **OK** to display the Diagnostics dialog. See Figure 4-1.

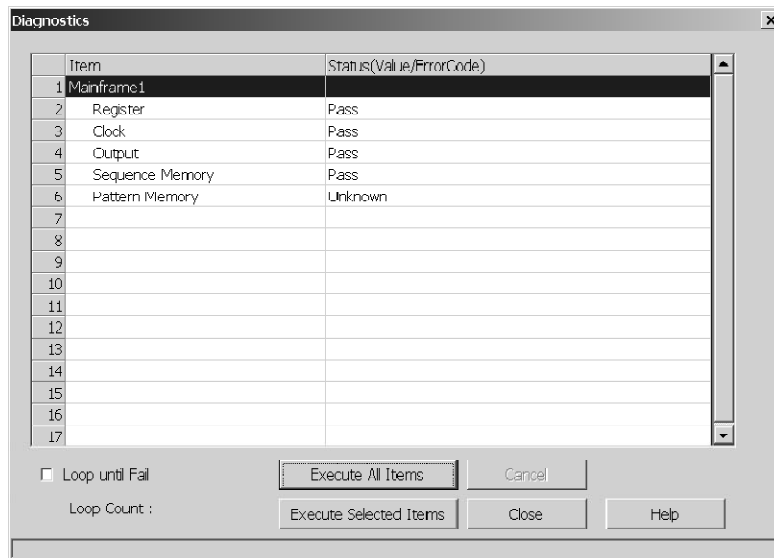

Figure 4-1: Diagnostics dialog

- Verify that the **Loop until Fail** box is not checked. If it is checked, click the box to remove the check mark.
- Select **Execute All Items** to start the diagnostics.

- b. Wait: Running the internal diagnostics takes one to six minutes. When it is finished, a message appears in the diagnostics control window.
 - c. Verify that no failures are found and reported: All tests should pass. Confirm that the word **Pass** appears in all the **Status** fields. If any failures occur, record the failure information and contact your local Tektronix service personnel for more information.
3. Select **Close** to exit the diagnostics.

Calibration

Two types of calibrations are provided in the DTG5000 Series Data Timing Generator.

- The *Level Calibration* uses internal calibration routines that check electrical characteristics such as DC accuracy of data output, and then adjust the internal calibration constants as necessary.
- The *Skew Calibration* checks the delay time of data output, and then adjusts the internal calibration constants as necessary. The calibration is performed by connecting each channel output to Skew Cal In.

NOTE. Level Calibration and Skew Calibration are not valid until the instrument reaches a valid temperature.

Level Calibration

Equipment required	None
Prerequisites	Power on the instrument and allow a 20 minute warmup at an ambient temperature between +20° C and +30° C before doing this procedure. The calibration routine must be performed whenever the ambient temperature changes by 5° C or more.

1. Set up the instrument:
 - Confirm that there is no output being performed by verifying that the **RUN** button indicator is not on. If the indicator is on, push the **RUN** button to turn it off.
 - Verify that the output module LEDs are not on. If any output module LEDs are on, push the **ALL OUTPUTS ON/OFF** button to turn the LEDs off.

2. Perform the calibration suite:

- a. From the application menu bar, select **System**, and then select **Level Calibration...**. The Level Calibration dialog appears. See Figure 4-2.

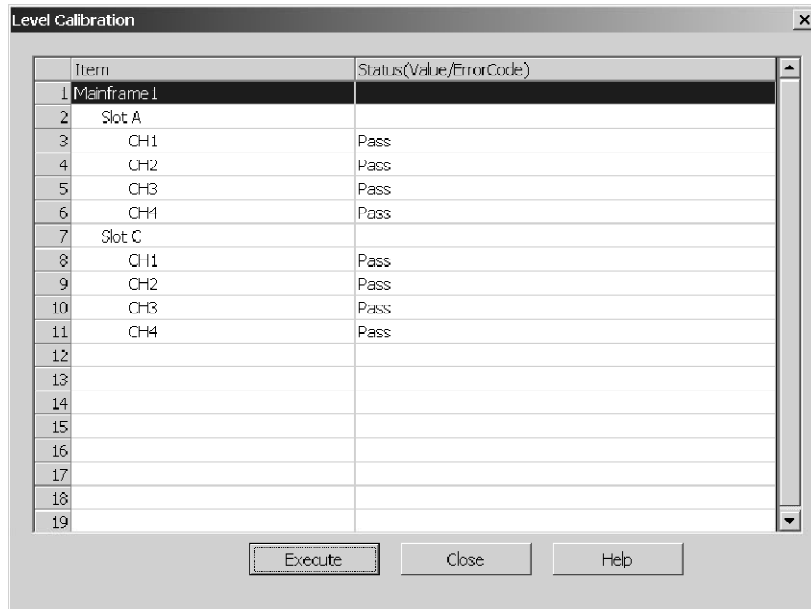

Figure 4-2: Level Calibration dialog

- b. Select **Execute**.
 - c. All the Status fields must be **Pass**. If any failures occur, record the failure information and contact your local Tektronix service personnel for more information.
3. Select **Close** to exit the calibration.

Skew Calibration

Equipment required	One 50 Ω SMA coaxial cable, Tektronix part number 174-1427-00 Refer to test equipment list on page 4-12.
Prerequisites	Power on the instrument and allow a 20 minute warmup at an ambient temperature between +20° C and +30° C before doing this procedure. The calibration routine must be performed whenever the ambient temperature changes by 5° C or more.

1. Set up the instrument:

- Confirm that there is no output being performed by verifying that the **RUN** button indicator is not on. If the indicator is on, push the **RUN** button to turn it off.
- Verify that the output module LEDs are not on. If any output module LEDs are on, push the **ALL OUTPUTS ON/OFF** button to turn the LEDs off.

2. Perform the calibration suite:

- a. From the application menu bar, select **System**, and then select **Skew Calibration**. The following dialog appears if you have changed the settings. Click **OK**.

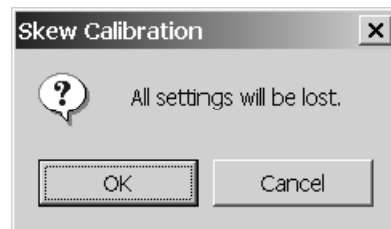

- b. The Skew Calibration dialog appears. See Figure 4-3.

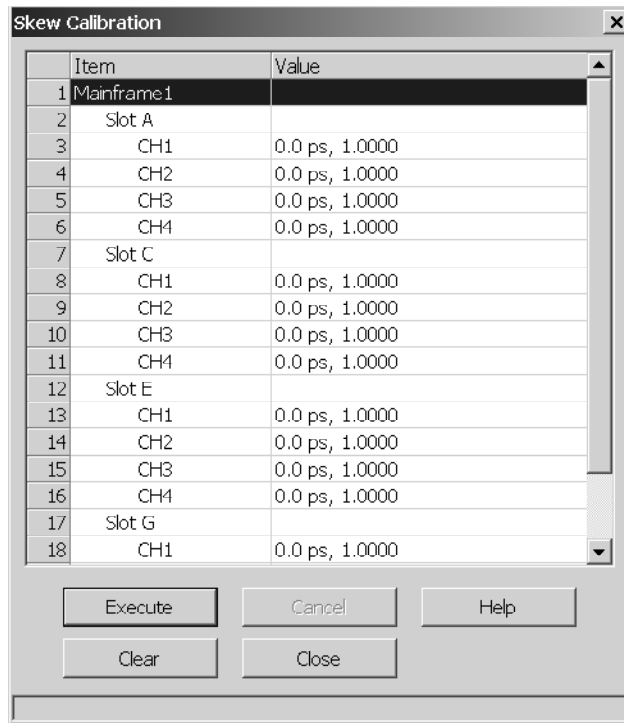

Figure 4-3: Skew Calibration dialog

- c. Attach an SMA coaxial cable to the **SKEW CAL IN** at the front panel of the data timing generator mainframe.
- d. Select **Execute** to display the dialog box shown below.



- e. Connect the opposite end of the SMA coaxial cable to the **CH1** connector of output module and select **OK** to start the calibration. Wait until the calibration completes.
- f. Follow the on-screen instruction to continue the calibration:
 - Disconnect the cable from the channel and reconnect it to next channel.

- Repeat the same calibration procedure for all channels.

NOTE. When you connect the output module and Skew Cal In, use the identical cable. If you use different cables, the calibration result may be affected.

- g. When complete, the resulting status appears on the screen. See Figure 4-4.

Item	Value
1 Mainframe1	
2 Slot A	
3 CH1	0.0 ps, 1.0049
4 CH2	18.9 ps, 1.0039
5 CH3	50.2 ps, 1.0081
6 CH4	39.4 ps, 1.0081
7 Slot C	
8 CH1	1.2 ps, 1.0041
9 CH2	37.8 ps, 1.0047
10 CH3	75.2 ps, 1.0074
11 CH4	41.6 ps, 1.0075
12 Slot E	
13 CH1	214.5 ps, 0.9989
14 CH2	271.4 ps, 1.0011
15 CH3	267.5 ps, 1.0021
16 CH4	214.5 ps, 1.0008
17 Slot G	
18 CH1	272.9 ps, 0.9963

Buttons: Execute, Cancel, Help, Clear, Close

Figure 4-4: Skew Calibration results screen

- h. Verify that no failures are found and reported on the screen.
 - i. If any failures occur, record the failure information and contact your local Tektronix service personnel for more information.
3. Select **Close** to exit the calibration.

NOTE. The calibration data in the memory may be lost if the instrument is powered off while the calibration is executed.

Performance Tests

The *Performance Tests* include functional test items, such as the interface functional test, in this manual.

- The *Functional Tests* verify that the DTG5000 Series Data Timing Generator features work. They do not verify that they operate within limits.
- The *Performance Tests* verify that the DTG5000 Series Data Timing Generator performs as warranted. The *Performance Tests* check all the characteristics that are designated as checked in *Specifications*. (The characteristics that are checked appear with a ✓ in *Specifications*.)

Table 4-1: Performance test items

Titles	Test Items	Reference page
DTG5000 series mainframe ¹		
Sync output	Output level	Page 4-15
Internal clock frequency	Internal clock output frequency accuracy	Page 4-18
External clock output	External clock output amplitude, rise time/ fall time, and aberration	Page 4-20
External clock input	External clock input function and external clock input frequency accuracy	Page 4-22
10 MHz reference input	10 MHz reference input function	Page 4-25
10 MHz reference output	10 MHz reference output frequency and output level	Page 4-26
Phase lock input	Phase lock input function	Page 4-28
Internal automatic trigger	Internal auto trigger function	Page 4-30
Trigger input	Trigger input function	
Event input and sequence function	Event input function, jump out function for master-slave operation, and sequence operation	Page 4-33
All jitter generation	Jitter profile and jitter volume	Page 4-38
Partial jitter generation	Jitter profile and jitter volume	Page 4-40
DC output	DC output accuracy	Page 4-42
Skew and delay timing	Skew time between channels (after skew calibration)	Page 4-44
Clock out random jitter	Clock out random jitter	Page 4-47
Random jitter	Random jitter	Page 4-50
Total jitter	Total jitter	Page 4-53
PG Mode	Frequency, Duty, and Mode	Page 4-54
Master-Slave operation	Master-Slave operation	Page 4-57

Table 4-1: Performance test items (cont.)

Titles	Test items	Reference page
Output module		
Data output DC level	Output level accuracy	Page 4-62
Data format	NRZ, RZ, and NRI	Page 4-67

- ¹ **At least one output module, which operates correctly, must be installed into the DTG5000 series mainframe slot when you execute the performance tests.**

Prerequisites

The tests in this section comprise an extensive, valid confirmation of performance and functionality when the following requirements are met:

- The cabinet must be installed on the instrument.
- Allow 20 minutes warm up period.
- You must have performed and passed the procedures under *Self Tests*, found on page 4-3.
- The data timing generator must have been last adjusted at an ambient temperature between +20° C and +30° C, and must have been operating for a warm-up period of at least 20 minutes.
- The *Performance Tests* must be executed at an ambient temperature between +10° C and +40° C.

Equipment Required

Table 4-2 lists the required equipment used to complete the performance tests.

Table 4-2: Test equipment

Item number and description	Minimum requirements	Recommended equipment or equivalent	Purpose
1. Frequency Counter	50 kHz to 5 GHz, Accuracy: < 0.2 ppm	Agilent 53181A op.050/010	Checks clock frequency.
2. Digital Mult-Meter	DC volts range: - 10 V to +10 V, Accuracy: ± 1%	Fluke 8842A	Measures voltage. Used in multiple procedures.
3. Oscilloscope	Bandwidth: > 1 GHz, Number of channel: > 4, 1 MΩ and 50 Ω inputs	Tektronix TDS7104	Checks output signals. Used in multiple procedures.
4. Sampling Oscilloscope	Bandwidth: > 20 GHz, Rise time: < 17.5 ps, 50 Ω input	Tektronix CSA8000B, 80E03 ²	Checks output signals. Used in multiple procedures.
5. Function Generator	Output voltage: -5 V to +5 V, Frequency accuracy: < 0.01%	Tektronix AFG320	Generates external input signals. Used in multiple input signal test procedures.

Table 4-2: Test equipment (cont.)

Item number and description	Minimum requirements	Recommended equipment or equivalent	Purpose
6. SMA Coaxial Cable (3 required)	50 Ω , male to male SMA connector	Tektronix part number 174-1427-00	Signal interconnection
7. BNC Coaxial Cable (3 required)	50 Ω , male to male BNC connector	Tektronix part number 012-0076-00	Signal interconnection
8. Adapter (2 required)	SMA (male) to BNC (female), 50 Ω	Tektronix part number 015-0554-00	Signal interconnection
9. Adapter (2 required)	SMA (female) to BNC (male), 50 Ω	Tektronix part number 015-0572-00	Signal interconnection
10. Adapter	N (male) to SMA (male), 50 Ω	Tektronix part number 015-0369-00	Signal interconnection
11. Adapter	SMA (female) to SMA (female), 50 Ω	Tektronix part number 015-1012-00	Signal interconnection
12. Lead set for DC output	16-CON twisted pair, 60 cm (24in)	Tektronix part number 012-A229-00	Signal interconnection
13. Dual-Banana Plug	BNC (female) to dual banana	Tektronix part number 103-0090-00	Signal interconnection
14. BNC-T Connector	BNC (male) to BNC (female) to BNC (female)	Tektronix part number 103-0030-00	Signal interconnection
15. Feed-through Termination	50 Ω , 0.1%, BNC	Tektronix part number 011-0129-00	Signal termination
16. SMA Termination	50 Ω , SMA	Tektronix part number 015-1022-01	Signal termination
17. Attenuator (2 required)	12 dB, SMA	---	Signal attenuation

² For best repeatability and to prolong the life of both connectors, use a torque wrench (5/16 in) and tighten the connection to the range of 7-10 lb-in (79-112 N-cm) when you connect an SMA cable to a sampling module. For more information, refer to your sampling module user manual.



CAUTION. Sampling modules are inherently vulnerable to static damage. Always observe static-safe procedures and cautions as outlined in the sampling module user manual.

Loading Files

The following steps explain how to load files from the DTG5000 Series Data Timing Generator.

1. From the application menu bar, select **File**, and then select **Open Setup**. The Open Setup dialog appears. See Figure 4-5.
2. Specify **C:\Program Files\Tektronix\DTG5000\PV\DTG5078** (or **C:\Program Files\Tektronix\DTG5000\PV\DTG5274**) to **Look in** field.

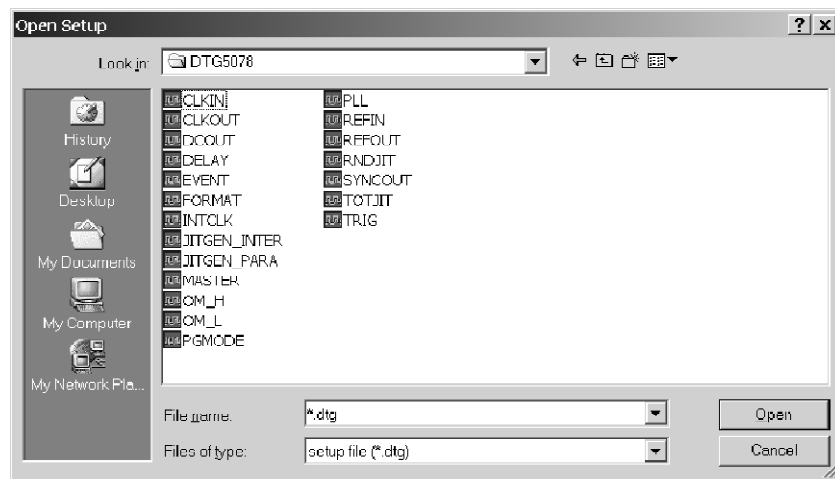

Figure 4-5: Open Setup dialog

3. Select the necessary file in the **File name:**, and then click **Open**.
4. The Open Setup Dialog automatically disappears, and then the selected waveform and sequence file are loaded.

If your data timing generator mainframe is not equipped with maximum output module configuration, the following dialog box appears.



5. Click **OK** to complete the instrument setup.

Performance Check Files Table 4-3 lists the setup files on the internal hard disk drive that are used in these performance tests. A specified file must be loaded each time you execute Performance Test procedure. Test pattern data and setup information are included in the file.

Table 4-3: Performance check files

No.	File name	Clock frequency	Test item
1	SYNCOUT.dtg	Internal: 10 MHz	Sync output
2	INTCLK.dtg	Internal: 100 MHz	Internal clock frequency
3	CLKOUT.dtg	Internal: 10 MHz	External clock output
4	CLKIN.dtg	External clock: 10 MHz	External clock input
5	REFIN.dtg	External reference: 100 MHz	10 MHz reference
6	PLL.dtg	External PLL: 10 MHz	Phase lock input
7	TRIG.dtg	Internal: 2.7 GHz (DTG5274) Internal: 750 MHz (DTG5078)	Trigger input
8	EVENT.dtg	Internal: 2.7 GHz (DTG5274) Internal: 750 MHz (DTG5078)	Event input and sequential function
9	JITGEN_INTER.dtg	Internal: 100 MHz	Total jitter
10	JITGEN_PARA.dtg	Internal: 100 MHz	Partial jitter
11	DCOUT.dtg		
12	REFOUT.dtg	Internal: 100 MHz	10 MHz reference output
13	DELAY.dtg		
14	PGMODE.dtg	Internal: 100 MHz	PG mode
15	OM_H.dtg		
16	OM_L.dtg		
17	FORMAT.dtg	Internal: 10 MHz	Data format
18	MASTER.dtg	Internal: 20 MHz	Master-Slave operation
19	RNDJIT.dtg		Random jitter
20	TOTJIT.dtg		Total jitter

Mainframe

The following procedures check those characteristics that relate to the mainframe that are checked under *Mainframe* in *Specifications*. Refer to page 1-6.

NOTE. *To perform the Performance Tests, at least one output module must be installed in the DTG5000 Series Data Timing Generator mainframe. You can select any slot when you perform the tests even though the descriptions below are assuming the Slot A is used.*

Sync Output This test verifies that the DTG5000 series mainframe sync output is functional.

Equipment required	One oscilloscope (TDS7104) (item 3) Two 50 Ω SMA coaxial cables (item 6) Two SMA (female)-BNC (male) adapters (item 9)
Prerequisites	The DTG5000 Series Data Timing Generator must meet the prerequisites listed on page 4-11.

1. Install the test hookup and preset the instrument controls:
 - a. Hook up the oscilloscope:
 - Attach SMA (female)-BNC (male) adapters to the oscilloscope **CH1 input** and **CH2 input** connectors.
 - Connect an SMA coaxial cable from the **CH2** connector of output module, which is inserted in the slot A of DTG5000 series mainframe, to the SMA-BNC adapter (CH2 input of oscilloscope).
 - Connect an SMA coaxial cable from the **SYNC OUT** at the front panel of the DTG5000 series mainframe to the SMA-BNC adapter (CH1 input of the oscilloscope). See Figure 4-6.

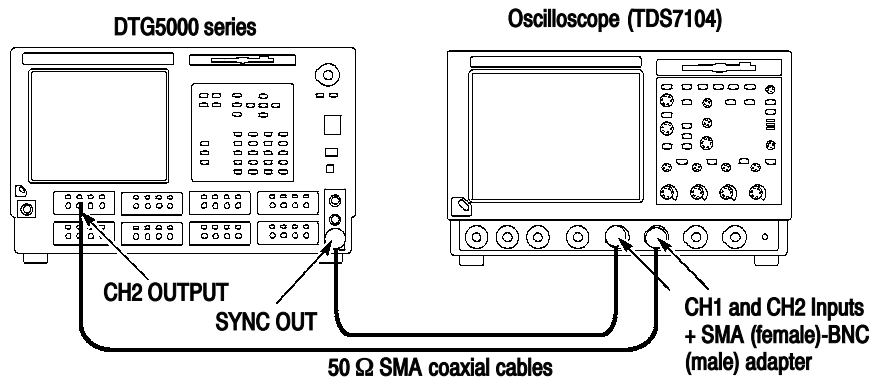

Figure 4-6: Sync output tests

b. Set the oscilloscope controls as follows:

Vertical .	
CH1 and CH2 coupling	DC
CH1 scale	100 mV/div
CH2 scale	200 mV/div
CH1 and CH2 input impedance . . .	50 Ω
CH1 offset	-200 mV
Horizontal	
Scale	80 ns/div
Acquisition	
Mode	Average
Number of running averages	32
Trigger	
Source	CH2
Coupling	DC
Slope	Positive
Level	500 mV
Mode	Auto
Measurement	CH1 High CH1 Low

2. Set the data timing generator controls and load the setup file:

- a. Load the setup file (SYNCOUT.dtg). Refer to *Loading Files* on page 4-13.
- b. After the file is loaded, the **Frequency** of data timing generator is set to 10MHz.

3. Push the **RUN** button of the data timing generator to light the **RUN LED**, and then push the **ALL OUTPUTS ON/OFF** button to activate the output.
4. Confirm the oscilloscope screen: Verify that the 400 ns width square waveform appears in the CH1 display.
5. Using the oscilloscope Measurement functions, verify that the High Level and Low Level values of Sync Out are within the following range.
 - High Level: $0\text{ V} \pm 50\text{ mV}$
 - Low Level: $-0.4\text{ V} \pm 50\text{ mV}$

Internal Clock Frequency

This test verifies the frequency accuracy of internal clock.

Equipment required	One frequency counter (item 1) One 50 Ω SMA coaxial cable (item 6) One SMA (female) - BNC (male) adapter (item 9) One N (male) - SMA (male) adapter (item 10) One SMA (female) - SMA (female) adapter (item 11)
Prerequisites	The DTG5000 Series Data Timing Generator must meet the prerequisites listed on page 4-11.

1. Install the test hookup and preset the instrument controls:

a. Hook up the frequency counter:

- Attach an SMA (female)-BNC (male) adapter to the **CHANNEL 1** input of frequency counter.
- Attach a N (male)-SMA (male) adapter to the **CHANNEL 2** input of frequency counter, and then attach an SMA (female)-SMA (female) adapter to the N-SMA adapter.
- Connect an SMA coaxial cable from the **CLOCK OUT** at the rear panel of DTG5000 series mainframe through the SMA-SMA and N-SMA adapters to the frequency counter **CHANNEL 2** input. See Figure 4-7.

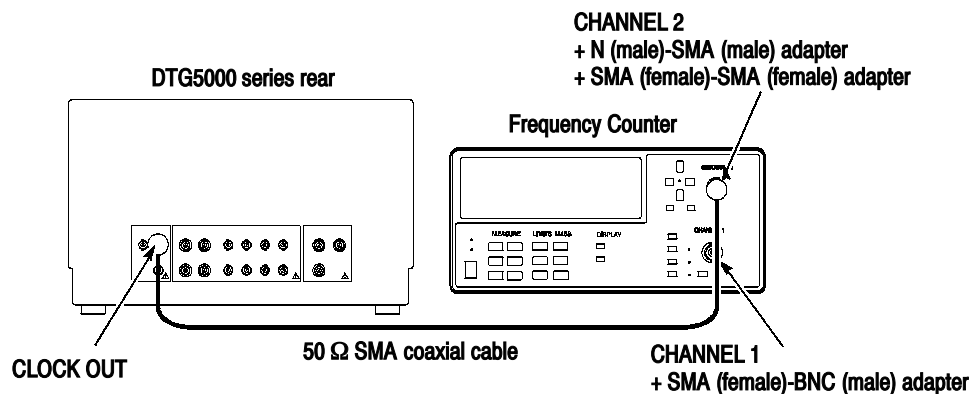

Figure 4-7: Internal Clock Frequency tests

- b. Power on the frequency counter, and verify that the frequency counter is set to frequency measurement mode (default setting).**

2. Load the setup file (INTCLK.dtg). Refer to *Loading Files* on page 4-13.
3. Push the **RUN** button of the data timing generator to light the RUN LED, and then push the **ALL OUTPUTS ON/OFF** button to activate the output.
4. Set the frequency counter trigger to an appropriate value, and then verify that the frequency counter reading is between 99.9999 MHz and 100.0001 MHz.
5. From the application menu bar, select **Settings**, and then select **Timing**.
6. Move cursor to **Clock Frequency** with the TAB key, and then set frequency counter as follows.

DTG5078

Setup frequency	Range	Frequency counter input
750.00000 MHz	745.99925 MHz to 750.00075 MHz	CHANNEL 2
500.00000 MHz	499.99950 MHz to 500.00050 MHz	CHANNEL 2
499.99999 MHz	499.99949 MHz to 500.00049 MHz	CHANNEL 2
50.000000 kHz	49.999950 kHz to 50.000050 kHz	CHANNEL 1

DTG5274

Setup frequency	Range	Frequency counter input
3.3500000 GHz	3.34999665 GHz to 3.35000335 GHz	CHANNEL 2
2.7000000 GHz	2.699973 GHz to 2.700027 GHz	CHANNEL 2
2.0000000 GHz	1.9999980 GHz to 2.000020 GHz	CHANNEL 2
1.9999999 GHz	1.9999979 GHz to 2.000019 GHz	CHANNEL 2
50.000000 kHz	49.999950 kHz to 50.000050 kHz	CHANNEL 1

7. Verify that the frequency measurements are within the specified range.

NOTE. *Disconnect the SMA coaxial cable from CHANNEL 2 input and then connect it to CHANNEL 1 input of frequency counter for 50kHz measurements.*

External Clock Output This test verifies the rise time/fall time and aberration of external clock output.

Equipment required	One sampling oscilloscope with a 80E03 sampling module (item 4) Three 50 Ω SMA coaxial cables (item 6) Two attenuators (item 17)
Prerequisites	The DTG5000 Series Data Timing Generator must meet the prerequisites listed on page 4-11.

1. Install the test hookup and preset the instrument controls:

a. Hook up the oscilloscope:

- Attach the attenuator to **CH1 input** and **CH2 input** of the 80E03 sampling module.
- Connect an SMA coaxial cable from the **CLOCK OUT** at the rear panel of DTG5000 series mainframe to the **CH1 input** of the 80E03 sampling module.
- Connect an SMA coaxial cable from the **CLOCK $\overline{\text{OUT}}$** at the rear panel of DTG5000 series mainframe to the **CH2 input** of the 80E03 sampling module.
- Connect an SMA coaxial cable from the **SYNC OUT** at the front panel of DTG5000 series mainframe to the **Trigger Direct Input** of sampling oscilloscope. See Figure 4-8.

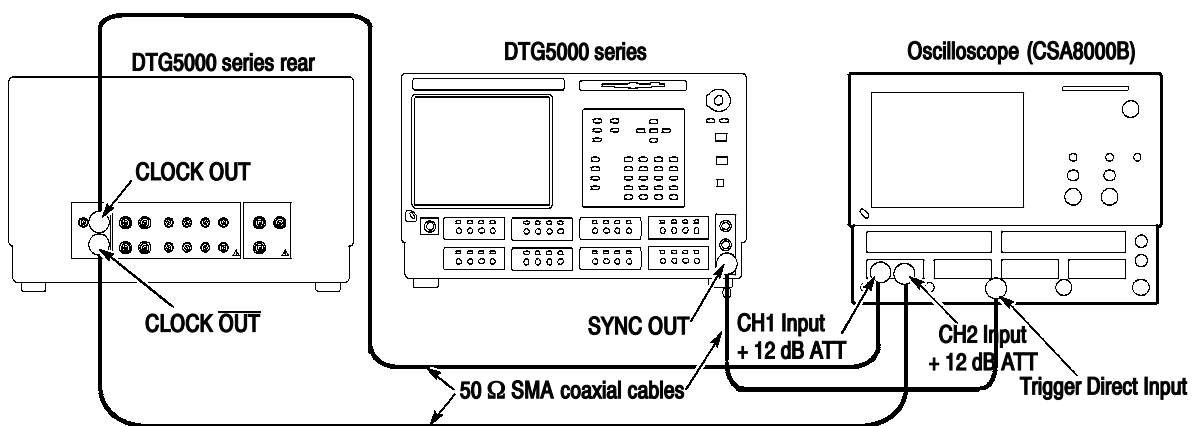

Figure 4-8: External Clock Output tests

b. Set the oscilloscope controls as follows:

Vertical	
CH1 scale	200 mV/div (with 12 dB ATT)
CH2 scale	200 mV/div (with 12 dB ATT)
	Select Setup -> Vertical -> External Attenuation , then set 12 dB .
Horizontal	
Scale	2 ns/div
Trigger	
Source	External Direct
Slope	Positive
Level	-200 mV
Measurement	Common to CH1 and CH2
Amplitude	
Positive Overshoot	
Negative Overshoot	
Rise Time	High Ref = 80%, Low Ref = 20%
Fall Time	High Ref = 80%, Low Ref = 20%

2. Load the setup file (CLKOUT.dtg). Refer to *Loading Files* on page 4-13.
3. Push the **RUN** (front) button of the data timing generator to light the RUN LED, and then push the **ALL OUTPUTS ON/OFF** (front) button to activate the output.
4. From the application menu bar, select **Settings**, and then select **Time Base**.
5. Move cursor to **Amplitude** with the TAB key.
6. Set the **Amplitude** values as shown in the following table.

Setup value	Typical value	
Amplitude	Aberration (Positive Overshoot and Negative Overshoot) ³	Rise Time and Fall Time ³
1.000 V ^{p-p}	<10 %	< 80 ps (DTG5274) < 100 ps (DTG5078)
0.100 V _{p-p}	---	< 70 ps (DTG5274) < 85 ps (DTG5078)

³ These are typical values. Typical specifications are provided for user convenience, but are not guaranteed.

7. Perform the following measurements for the oscilloscope CH1 input:
 - a. Verify the aberration: Confirm that the measurement results are approximately the same as stated in the list by observing the rising and falling edges of displayed waveform while adjusting the horizontal position.
 - b. Verify the rise time: Measure the rise time while observing the rising edge. Confirm that the measurement results are approximately the same values as stated in the list.
 - c. Verify the fall time: Measure the fall time while observing the falling edge. Confirm that the measurement results are approximately the same values as stated in the list.
 - d. Verify the amplitude: Confirm on the oscilloscope screen that the amplitude values are approximately the same level as specified by step 6 above.
8. Repeat the same measurements as 7-a through 7-d for the CH2 input.

External Clock Input

This test verifies the external clock input function and frequency measurement accuracy of the DTG5000 series mainframe.

Equipment required	One sampling oscilloscope with a 80E03 sampling module (item 4) One function generator (item 5) Two 50 Ω SMA coaxial cables (item 6) One 50 Ω BNC coaxial cable (item 7) One SMA (male)-BNC (female) adapter (item 8) One attenuator (item 17)
Prerequisites	The DTG5000 Series Data Timing Generator must meet the prerequisites listed on page 4-11.

1. Install the test hookup and preset the instrument controls:
 - a. Hook up the oscilloscope and function generator:
 - Attach the attenuator to **CH1 input** of the 80E03 sampling module.
 - Attach an SMA (male)-BNC (female) adapter to the **CLOCK EXTERNAL IN** at the rear panel of DTG5000 series mainframe.
 - Connect a BNC coaxial cable from the front panel **CH1 Out** of function generator to the SMA-BNC adapter (Clock External In).

- Connect an SMA coaxial cable from the **CLOCK OUT** at the rear panel of DTG5000 series mainframe to the **CH1 input** of the 80E03 sampling module.
- Connect an SMA coaxial cable from the **SYNC OUT** at the front panel of DTG5000 series mainframe to the **Trigger Direct Input** of sampling oscilloscope. See Figure 4-9.

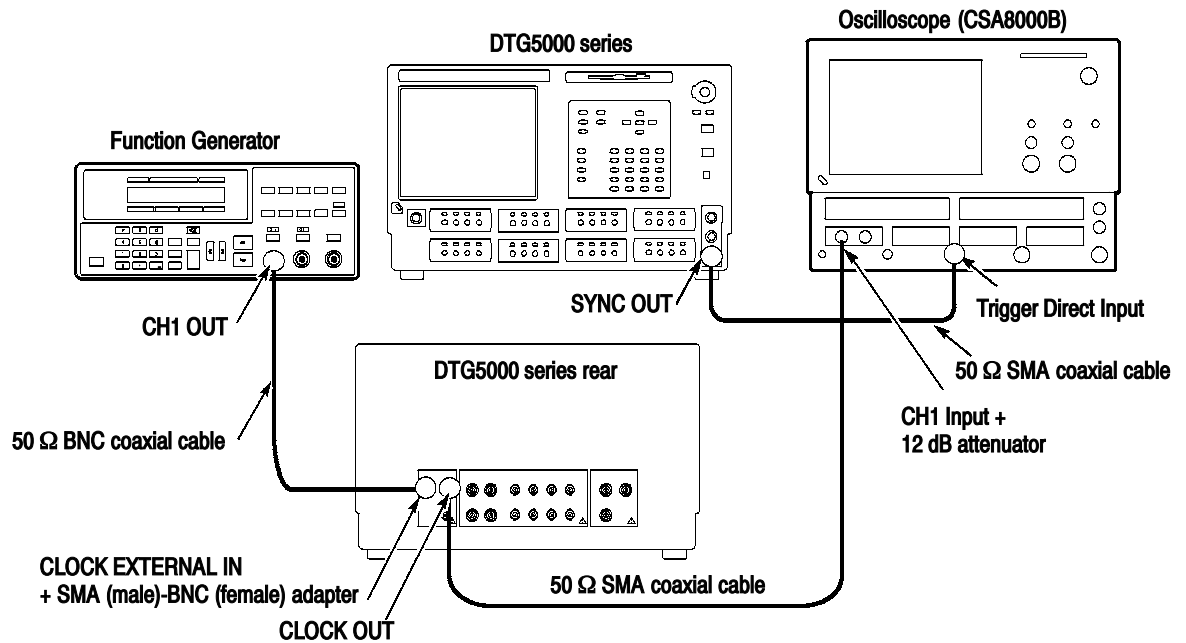

Figure 4-9: External Clock Input tests

b. Set the oscilloscope controls as follows:

Vertical	
CH1 scale	200 mV/div (with 12 dB ATT) Select Setup -> Vertical -> External Attenuation, then set 12 dB.
Horizontal	
Scale	50 ns/div
Trigger	
Source	External Direct
Slope	Positive
Level	-0.2 V

c. Set the function generator controls:

Output channel	CH1
Function	Square
Parameters	
Frequency	10 MHz
Amplitude	1.0 V into 50 Ω
Offset	0 mV
Output	Off

2. Load the setup file (CLKIN.dtg). Refer to *Loading Files* on page 4-13.
3. Turn the function generator **Output** on.
4. Push the **RUN** button of the data timing generator to light the RUN LED, and then push the **ALL OUTPUTS ON/OFF** button to activate the output.
5. Verify the displayed waveform: A 10 MHz, approximately 1 Vp-p clock pattern is displayed on the oscilloscope screen.
6. Verify the frequency: Push the **TIMING** button at the front panel of DTG5000 series mainframe and verify that 10.00 MHz (four digits) is displayed at the **Clock Frequency** field.

10 MHz Reference Input

This test verifies that the 10 MHz reference input of the DTG5000 series mainframe is functional.

Equipment required	One oscilloscope (TDS7104) (item 3) One function generator (item 5) Two BNC coaxial cables (item 7) One SMA (male)-BNC (female) adapter (item 8)
Prerequisites	The DTG5000 Series Data Timing Generator must meet the prerequisites listed on page 4-11.

1. Install the test hookup and preset the instrument controls:

a. Hook up the oscilloscope and function generator:

- Use an SMA (male)-BNC (female) adapter and a BNC coaxial cable to connect the **CLOCK OUT** at the rear panel of DTG5000 series mainframe and the **CH1 input** of oscilloscope.
- Connect a BNC coaxial cable from the **CH1 Out** at the front panel of function generator to the **EXTERNAL 10MHz REF IN** at the rear panel of DTG5000 series mainframe. See Figure 4-10.

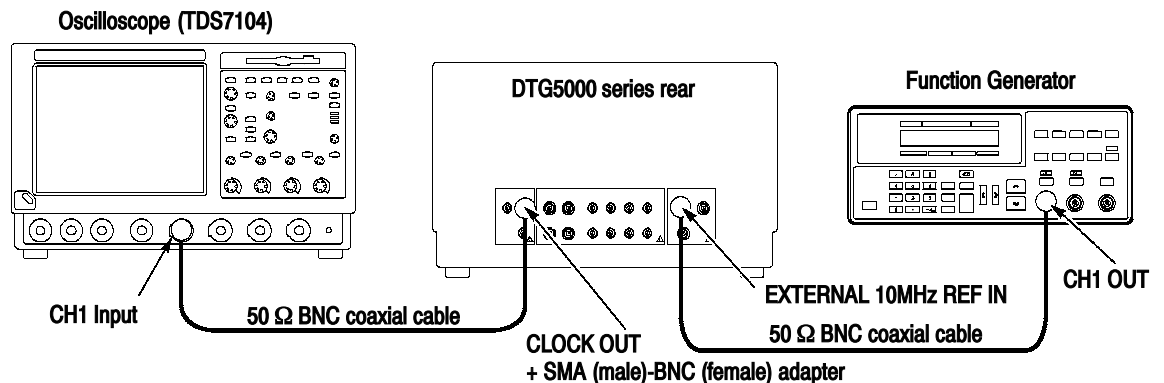

Figure 4-10: 10 MHz Reference Input tests

b. Set the oscilloscope controls as follows:

```

Vertical ..... CH1
  CH1 scale ..... 500 mV/div
  CH1 input impedance ..... 50 Ω
Horizontal
  Scale ..... 10 ns/div
Trigger
  Source ..... CH1
  Slope ..... Positive
  Level ..... + 0.5 V
    
```

c. Set the function generator controls:

```

Output channel ..... CH1
Function ..... Square
Parameters
  Frequency ..... 10 MHz
  Amplitude ..... 1.0 V into 50 Ω
  Offset ..... 0 mV
    
```

2. Load the setup file (REFIN.dtg). Refer to *Loading Files* on page 4-13.
3. Turn the function generator **Output** on.
4. Push the **RUN** button of the data timing generator to light the RUN LED, and then push the **ALL OUTPUTS ON/OFF** button to activate the output.
5. Verify the displayed waveform: A 100 MHz, approximately 1 V_{p-p} clock pattern is displayed on the oscilloscope screen.

10 MHz Reference Output

This test verifies that the 10 MHz reference output of the DTG5000 series mainframe is functional.

Equipment required	One oscilloscope (TDS7104) (item 3) One BNC coaxial cable (item 7)
Prerequisites	The DTG5000 Series Data Timing Generator must meet the prerequisites listed on page 4-11.

1. Install the test hookup and preset the instrument controls:
 - a. Hook up the oscilloscope:

- Connect a BNC coaxial cable from the **10MHz REF OUT** at the rear panel of DTG5000 series mainframe to the CH1 input of oscilloscope. See Figure 4-11.

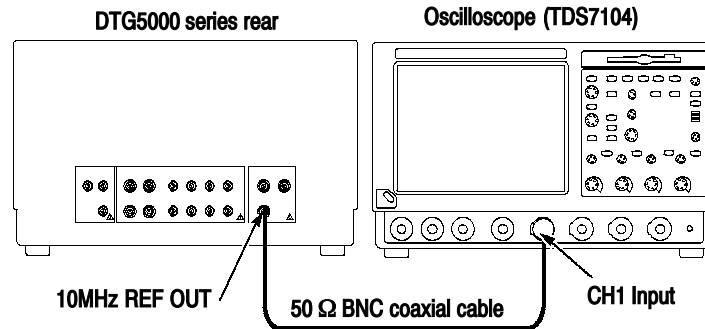

Figure 4-11: 10 MHz Reference Output tests

- b. Set the oscilloscope controls as follows:

Vertical	CH1
CH1 scale	500 mV/div
CH1 input impedance	50 Ω
CH1 offset	0.6 V
Horizontal	
Scale	40 ns/div
Trigger	
Source	CH1
Slope	Positive
Level	0.5 V

2. Load the setup file (REFOUT.dtg). Refer to *Loading Files* on page 4-13.
3. Push the **RUN** button of the data timing generator to light the RUN LED, and then push the **ALL OUTPUTS ON/OFF** button to activate the output.
4. Verify the displayed waveform: A 10 MHz, approximately 1.2 V_{p-p} clock pattern is displayed on the oscilloscope screen.
5. Modify the oscilloscope setting and verify the displayed waveform:
 - a. Change the CH1 impedance setting of oscilloscope to **1 MΩ**.
 - b. Verify that the amplitude of the clock pattern changes to approximately 2.4 V_{p-p}.

Phase Lock Input

This test verifies that the phase lock input of the DTG5000 series mainframe is functional.

Equipment required	One oscilloscope (TDS7104) (item 3) One function generator (item 5) Two BNC coaxial cables (item 7) One SMA (male)-BNC (female) adapter (item 8)
Prerequisites	The DTG5000 Series Data Timing Generator must meet the prerequisites listed on page 4-11.

1. Install the test hookup and preset the instrument controls:

a. Hook up the oscilloscope and function generator:

- Connect a BNC coaxial cable from the **CH1 Out** at the front panel of function generator to the **PHASE LOCK IN** at the rear panel of DTG5000 series mainframe.
- Use an SMA (male)-BNC (female) adapter and a BNC coaxial cable to connect the **CLOCK OUT** at the rear panel of DTG5000 series mainframe and the oscilloscope **CH1 input**. See Figure 4-12.

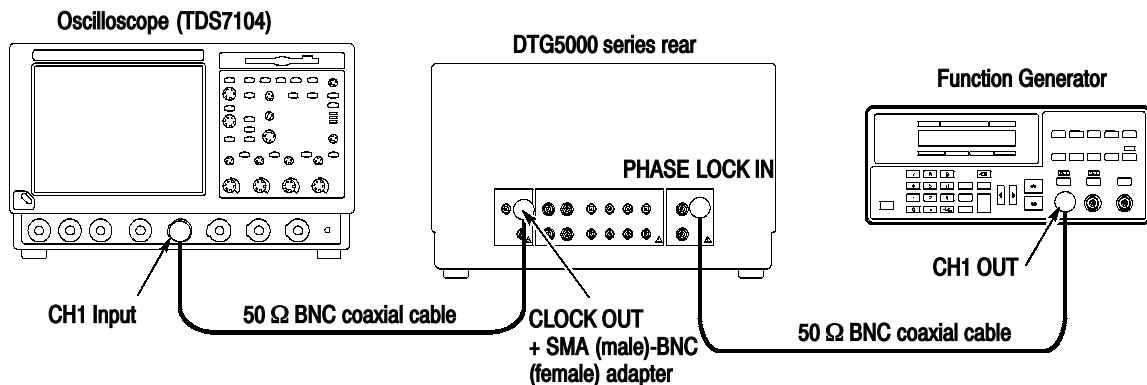

Figure 4-12: Phase Lock Input tests

b. Set the oscilloscope controls as follows:

- Vertical CH1
- CH1 scale 500 mV/div
- CH1 input impedance 50 Ω

Horizontal	
Scale	40 ns/div
Trigger	
Source	CH1
Slope	Positive
Level	+ 0.5 V

c. Set the function generator controls:

Output channel	CH1
Function	Square
Parameters	
Frequency	10.0 MHz
Amplitude	1.0 V into 50 Ω
Offset	0 mV
Output	Off

2. Load the setup file (PLL.dtg). Refer to *Loading Files* on page 4-13.
3. Turn the function generator **Output** on.
4. Push the **RUN** button of the data timing generator to light the RUN LED, and then push the **ALL OUTPUTS ON/OFF** button to activate the output.
5. Verify the displayed waveform: A 10 MHz, 1 V_{p-p} clock pattern is displayed on the oscilloscope screen.
6. Observe the clock pattern change:
 - a. From the application menu bar of DTG5000 series mainframe, select **Settings**, and then select **Timing**.
 - b. Move cursor to **Clock Frequency** with the TAB key.
 - c. Change the **Clock Frequency** to 20MHz, 30MHz, and 40MHz in this sequence.
 - d. Verify the displayed waveform on the oscilloscope screen:
A 10 MHz, 1 V_{p-p} clock pattern is changed to 20 MHz, 30 MHz, and 40 MHz in response to the clock frequency change.

Internal Auto Trigger and Trigger Input

This test verifies that the internal trigger is functional.

Equipment required	One oscilloscope (TDS7104) (item 3) One function generator (item 5) Three BNC coaxial cables (item 7) One SMA (male)-BNC (female) adapter (item 8)
Prerequisites	The DTG5000 Series Data Timing Generator must meet the prerequisites listed on page 4-11.

1. Install the test hookup and preset the instrument controls:

a. Hook up the oscilloscope and function generator:

- Connect a BNC coaxial cable from the **CH1 OUT** at the front panel of function generator to the **TRIGGER IN** at the front panel of DTG5000 series mainframe.
- Connect a BNC coaxial cable from the **CH2 OUT** at the front panel of function generator to the **CH2 input** of oscilloscope
- Use an SMA (male)-BNC (female) adapter and a BNC coaxial cable to connect the **SYNC OUT** at the front panel of DTG5000 series mainframe and the **CH1 input** of oscilloscope. See Figure 4-13.

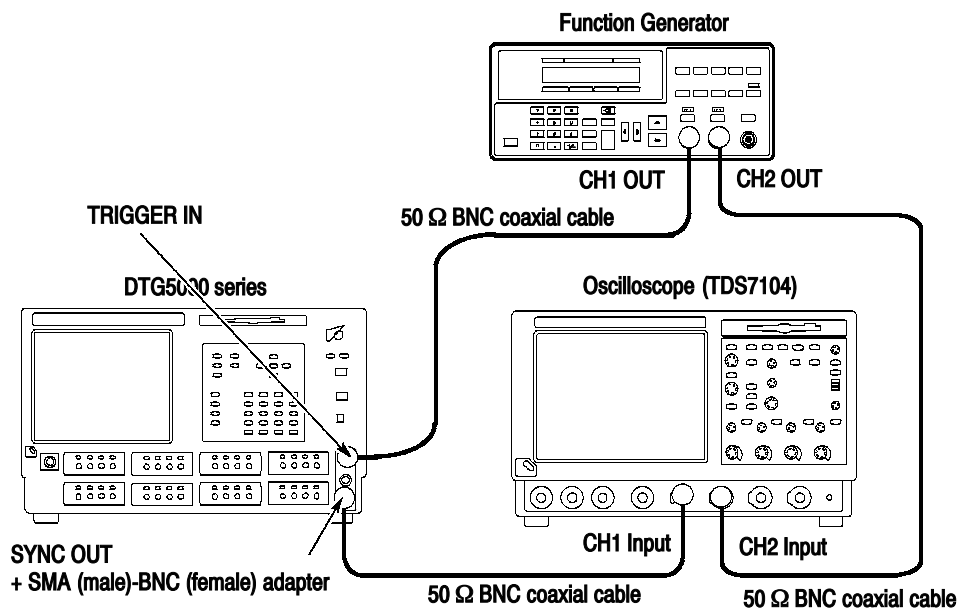

Figure 4-13: Internal Trigger tests

b. Set the oscilloscope controls as follows:

Vertical	
CH1 scale	200 mV/div
CH2 scale	1 V/div
CH1 and CH2 input impedance ...	50 Ω
Horizontal	
Scale	200 ns/div
Acquisition	
Mode	Peak Detect
Trigger	
Source	CH2
Mode	Normal
Slope	Positive
Level	0.5 V

c. Set the function generator controls:

Output channel	CH1, CH2
Function	Square (CH1, CH2)
Parameters	
Frequency	1 MHz (CH1, CH2)
Amplitude	1.0 V into 50 Ω (CH1, CH2)
Offset	0.5 V (CH1, CH2)
BOTH CH	Press SHIFT key, then press CH .

2. Load the setup file (TRIG.dtg). Refer to *Loading Files* on page 4–13.
3. Turn the function generator CH1 and CH2 Outputs **on**.
4. Push the **RUN** button of the data timing generator to light the RUN LED, and then push the **ALL OUTPUTS ON/OFF** button to activate the output.
5. Confirm the displayed waveforms: Verify that an approximately 0.4 V_{p-p} amplitude pulse waveform is generated from CH 1 every 1.00 μ s synchronizing with CH2 signal rising edge on the oscilloscope screen.
6. Observe the trigger level change effects:
 - a. From the application menu bar of DTG5000 series mainframe, select **Settings** and then select **Time Base**.
 - b. Move cursor to **Trigger Level** with the TAB key and set the trigger level to +1.1 V.

- c. Verify that the CH1 pulse signal disappears from the oscilloscope screen and that the data timing generator screen message changes to **Waiting Trigger**.
7. Change the trigger impedance and observe the waveform:
 - a. From the application menu bar of DTG5000 series mainframe, select **Settings**, and then select **Time Base**.
 - b. Move cursor to **Trigger Impedance** with the TAB key and set the trigger impedance to **1 kΩ**.
 - c. Verify that an approximately $0.4 V_{p-p}$ amplitude pulse waveform is generated from CH 1 every $1.00 \mu s$ synchronizing with CH2 signal rising edge on the oscilloscope screen.
8. Observe the trigger level change effects:
 - a. From the application menu bar of DTG5000 series mainframe, select **Settings** and then select **Time Base**.
 - b. Move cursor to **Trigger Level** with the TAB key and set the trigger level to **- 0.4 V**.
 - c. Verify that the CH1 pulse signal disappears from the oscilloscope screen and that the data timing generator screen message changes to **Waiting Trigger**.
9. Change the trigger level and trigger slope, and then observe the waveform:
 - a. From the application menu bar of DTG5000 series mainframe, select **Settings** and then select **Time Base**.
 - b. Move cursor to **Trigger Level** and **Trigger Slope** with TAB key. Set the trigger level to **+1.0 V** and trigger slope to **Negative**.
 - c. Confirm the displayed waveform: Verify that an approximately $0.4 V_{p-p}$ amplitude pulse waveform is generated from CH 1 every $1.00 \mu s$ synchronizing with CH2 signal falling edge on the oscilloscope screen.
10. Turn the function generator CH1 and CH2 Outputs **off**.
11. Change the trigger source and trigger level, and then observe the waveform:
 - a. Set the oscilloscope trigger source to **CH1** and trigger level to **- 0.2 V**.
 - b. Confirm the displayed waveform: Each time you push the **MANUAL TRIGGER** button at the front panel of DTG5000 series mainframe, the oscilloscope screen is updated with a pulse waveform.
12. Push the **RUN** button of the data timing generator to turn the RUN LED off.

- 13.** Change the trigger source and interval, and then observe the waveform:
- From the application menu bar of DTG5000 series mainframe, select **Settings** and then select **Time Base**.
 - Move cursor to **Trigger Source** with the TAB key and set to **Internal**.
 - Set the **Interval** to 1.00 μs .
 - Push the **RUN** button of the data timing generator to light the RUN LED.
 - Verify that an approximately 0.4 V_{p-p} amplitude pulse waveform is generated every 1.00 μs on the oscilloscope screen.
- 14.** Change the Interval setting and observe the waveform:
- Change the **Interval** from 1.00 μs to 1.00 ms.
 - Change the horizontal scale of the oscilloscope from 200 ns/div to **200 $\mu\text{s}/\text{div}$** .
 - Verify that an approximately 0.4 V_{p-p} amplitude pulse waveform is generated every 1.00 ms on the oscilloscope screen.

Event Input and Sequence Function

This test verifies that the event input and sequence of the DTG5000 series mainframe are functional.

Equipment required	One oscilloscope (TDS7104) (item 3) One function generator (item 5) One 50 Ω SMA coaxial cable (item 6) Three 50 Ω BNC coaxial cables (item 7) One SMA (female)-BNC (male) adapter (item 9) One BNC-T connector (item 14)
Prerequisites	The DTG5000 Series Data Timing Generator must meet the prerequisites listed on page 4-11.

1. Install the test hookup and preset the instrument controls:

a. Hook up the oscilloscope and function generator:

- Attach a BNC-T connector to the **CH3 input** of the oscilloscope.
- Connect a BNC coaxial cable from the **CH1 Out** of function generator to the **CH3 input** of the oscilloscope (through BNC-T connector).
- Connect a second BNC coaxial cable to the **EVENT IN** at the front panel of DTG5000 series mainframe, and then connect the opposite end of the cable to the **CH3 input** of the oscilloscope (through BNC-T connector).
- Connect a third BNC coaxial cable from the **JUMP OUT1** at the rear panel of DTG5000 series mainframe to the **CH2 input** of oscilloscope.
- Attach an SMA (female)-BNC (male) adapter to the oscilloscope **CH1 input** connector.
- Connect an SMA coaxial cable from the **CH1** connector of the output module, which is inserted in the slot A of DTG5000 series mainframe, to the SMA-BNC adapter (CH1 input of oscilloscope). See Figure 4-14.

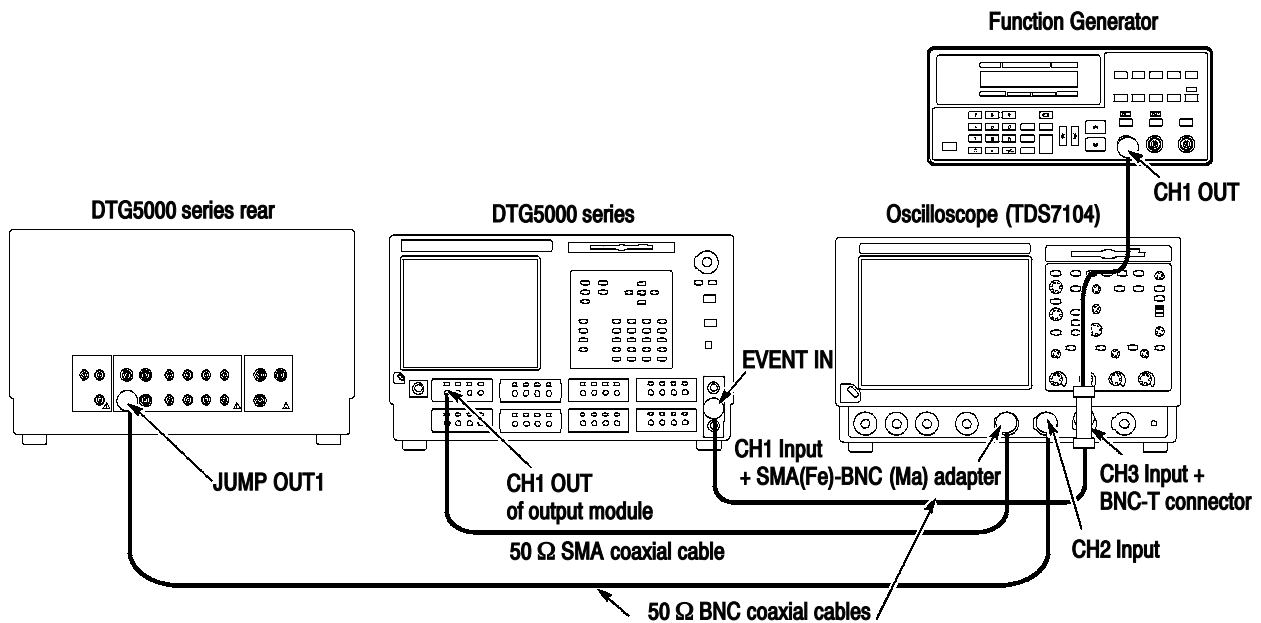

Figure 4-14: Event Input and Sequence tests

b. Set the oscilloscope controls as follows:

Vertical	
CH1 and CH3 scale	1 V/div
CH2 scale	2 V/div
CH1 input impedance	50 Ω
CH2 and CH3 input impedance ...	1 M Ω
Horizontal	
Scale	200 ns/div
Acquisition	
Mode	Peak Detect
Sequence	RUN/STOP button Only
Trigger	
Source	CH3
Mode	Normal
Slope	Positive
Level	+ 0.5 V
Coupling	DC
Position	50%

c. Set the function generator controls:

Output channel	CH1
Function	Square (CH1 and CH2)
Parameters	
Frequency	500 Hz (CH1 and CH2)
Amplitude	1.0 V into 50 Ω (CH1 and CH2)
Offset	0.5 V (CH1 and CH2)

2. Load the setup file (EVENT.dtg). Refer to *Loading Files* on page 4-13.
3. Turn the function generator **Output** on.
4. Push the **RUN** button of the data timing generator to light the RUN LED, and then push the **ALL OUTPUTS ON/OFF** button to activate the output.
5. Verify that the oscilloscope displays data pattern such as shown in Figure 4-15.

NOTE. The CH1 and CH2 signals appear to have jitters. The DTG5274 has 120 clocks width jitter and the DTG5078 has 30 clocks width jitter compared to CH3 trigger signal.

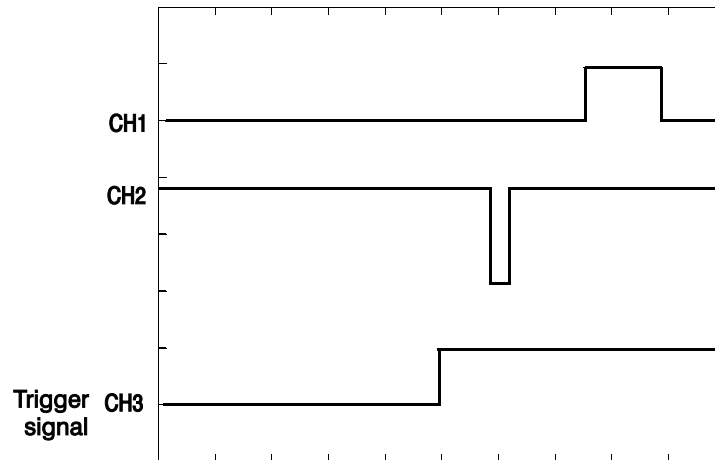

Figure 4-15: Data pattern example

6. Verify the waveform after **trigger source** and **trigger level** settings change:
 - a. Set the trigger source to **CH2** and the trigger level to **+ 1.4 V**.
 - b. Verify that an approximately 3.3 V_{p-p} amplitude low pulse waveform is generated from CH 2 synchronizing with CH3 signal rising edge on the oscilloscope screen.
7. Change the DTG5000 series mainframe settings and verify the waveform:
 - a. From the application menu bar of DTG5000 series mainframe, select **Settings** and then select **Time Base**.
 - b. Set the **Event Input Polarity** to **Invert**.
 - c. Verify that an approximately 3.3 V_{p-p} amplitude low pulse waveform is generated from CH 2 synchronizing with CH3 signal falling edge on the oscilloscope screen.
8. Change the DTG5000 series mainframe settings and verify that the oscilloscope untriggered:
 - a. From the application menu bar of DTG5000 series mainframe, select **Settings** and then select **Time Base**.
 - b. Set the **Event Input Threshold** to **+ 1.1 V**.
 - c. Confirm that the oscilloscope does not trigger.
9. Change the DTG5000 series mainframe settings and verify the waveform:
 - a. From the application menu bar of DTG5000 series mainframe, select **Settings** and then select **Time Base**.

- b. Set the **Event Input Impedance** to **1 k Ω** .
 - c. Verify that an approximately 3.3 V_{p-p} amplitude low pulse waveform is generated from CH 2 synchronizing with CH3 signal falling edge on the oscilloscope screen.
10. Change the DTG5000 series mainframe settings and verify that the oscilloscope untriggered:
 - a. From the application menu bar of DTG5000 series mainframe, select **Settings** and then select **Time Base**.
 - b. Set the **Event Input Threshold** to **- 0.4 V**.
 - c. Confirm that the oscilloscope does not trigger.
11. Change the DTG5000 series mainframe settings and verify the waveform:
 - a. From the application menu bar of DTG5000 series mainframe, select **Settings** and then select **Time Base**.
 - b. Set the **Event Input Threshold** to **+ 1.0 V**.
 - c. Verify that an approximately 3.3 V_{p-p} amplitude low pulse waveform is generated from CH 2 synchronizing with CH3 signal falling edge on the oscilloscope screen.
12. Connect the cable to Jump Out2 and verify the displayed waveform:
 - a. Disconnect the BNC cable from the **JUMP OUT1** and then connect it to the **JUMP OUT2** at the rear panel of DTG5000 series mainframe.
 - b. Verify that an approximately 3.3 V_{p-p} amplitude low pulse waveform is generated from CH 2 synchronizing with CH3 signal falling edge on the oscilloscope screen.
13. (DTG5078 only) Connect the cable to Jump Out3 and verify the displayed waveform:
 - a. Disconnect the BNC cable from the **JUMP OUT2** and then connect it to the **JUMP OUT3** at the rear panel of DTG5000 series mainframe.
 - b. Verify that an approximately 3.3 V_{p-p} amplitude low pulse waveform is generated from CH 2 synchronizing with CH3 signal falling edge on the oscilloscope screen.
14. Turn the function generator **Output** off.
15. Each time you push the **MANUAL EVENT** button at the front panel of DTG5000 series mainframe, the oscilloscope screen is updated with data pattern same as step 12-b. Ignore the CH3 waveform.

All Jitter Generation

This test verifies that the all jitter generation is functional. This function is provided with the slot A CH1. While using this function, the slot A CH2 is in high impedance status.

Equipment required	One oscilloscope (TDS7104) (item 3) Two 50 Ω BNC coaxial cables (item 7) Two SMA (male)-BNC (female) adapters (item 8)
Prerequisites	The DTG5000 Series Data Timing Generator must meet the prerequisites listed on page 4-11.

1. Install the test hookup and preset the instrument controls:

a. Hook up the oscilloscope:

- Attach an SMA (male)-BNC (female) adapter to the **CH1** connector of the output module, which is inserted in the slot A of DTG5000 series mainframe.
- Attach an SMA (male)-BNC (female) adapter to the **SYNC OUT** at the front panel of DTG5000 series mainframe.
- Connect a BNC coaxial cable from the SMA-BNC adapter of output module to the **CH1 input** of oscilloscope.
- Connect a BNC coaxial cable from the **SYNC OUT** (SMA-BNC adapter) at the front panel of DTG5000 series mainframe to the **CH2 input** of oscilloscope. See Figure 4-16.

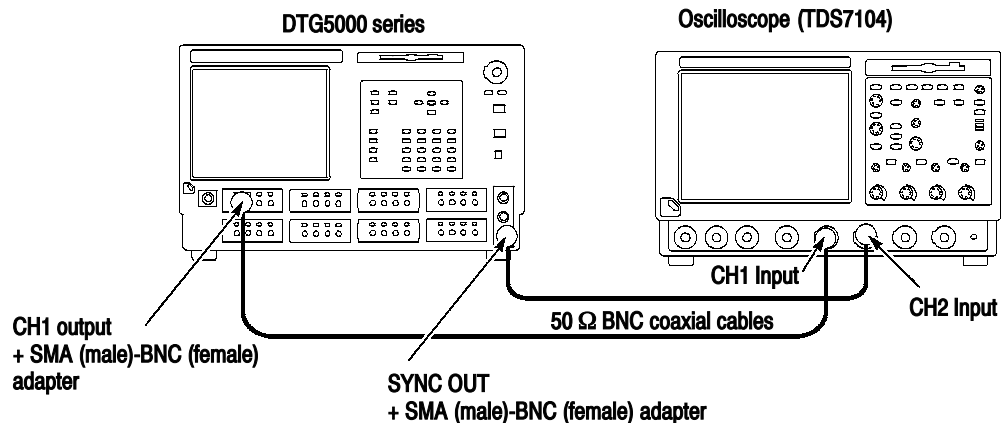

Figure 4-16: Jitter Generation tests

b. Set the oscilloscope controls as follows:

Vertical .

CH1 and CH2 scale 500 mV/div

CH1 and CH2 impedance 50 Ω

Horizontal

Scale 10 ns/div

Trigger

Source CH2

Slope Positive

Level -0.2 V

Display Infinite Persistence

2. Load the setup file (JITGEN_INTER.dtg). Refer to *Loading Files* on page 4-13.
3. Push the **RUN** button of the data timing generator to light the RUN LED, and then push the **ALL OUTPUTS ON/OFF** button to activate the output.
4. Confirm the jitter generation: In the example of Figure 4-17, a 4 ns width jitter appears on the rising and falling edges of every pulse.

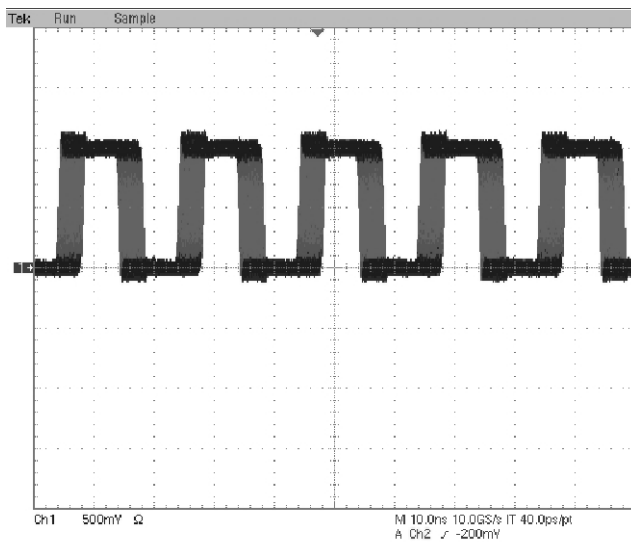

DTG5078

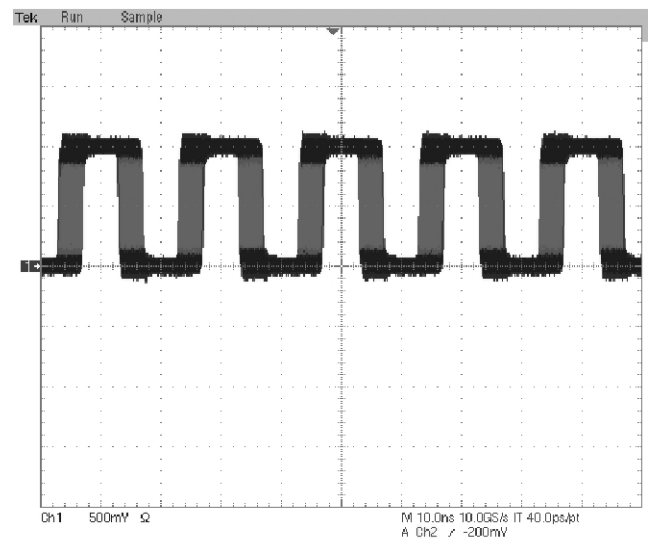

DTG5274

Figure 4-17: Jitter Generation example (all)

Partial Jitter Generation

This test verifies that the partial jitter generation is functional. This function is provided with the slot A CH1. While using this function, the slot A CH2 is in high impedance status.

Equipment required	One oscilloscope (TDS7104) (item 3) Two 50 Ω BNC coaxial cables (item 7) Two SMA (male)-BNC (female) adapters (item 8)
Prerequisites	The DTG5000 Series Data Timing Generator must meet the prerequisites listed on page 4-11.

1. Install the test hookup and preset the instrument controls:

a. Hook up the oscilloscope:

- Attach an SMA (male)-BNC (female) adapter to the **CH1** connector of the output module, which is inserted in the slot A of DTG5000 series mainframe.
- Attach an SMA (male)-BNC (female) adapter to the **SYNC OUT** at the front panel of DTG5000 series mainframe.
- Connect a BNC coaxial cable from the SMA-BNC adapter of output module to the **CH1 input** of oscilloscope.
- Connect a BNC coaxial cable from the **SYNC OUT** (SMA-BNC adapter) at the front panel of DTG5000 series mainframe to the **CH2 input** of oscilloscope. See Figure 4-16 on page 4-38.

b. Set the oscilloscope controls as follows:

Vertical .

CH1 and CH2 scale 500 mV/div
 CH1 and CH2 impedance 50 Ω

Horizontal

Scale 10 ns/div

Trigger

Source CH2
 Slope Positive
 Level -0.2 V
 Position Set to 10%

Display Infinite Persistence

2. Load the setup file (JITGEN_PARA.dtg). Refer to *Loading Files* on page 4-13.
3. Push the **RUN** button of the data timing generator to light the RUN LED, and then push the **ALL OUTPUTS ON/OFF** button to activate the output.
4. Press the Set Level to 50% on the oscilloscope.
5. Confirm the jitter generation: In the example of Figure 4-18, a 4 ns width jitter appears on the rising and falling edges of one pulse.

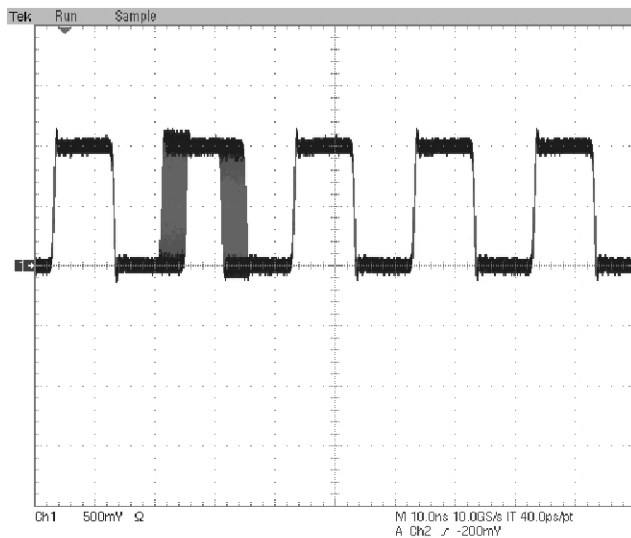

DTG5078

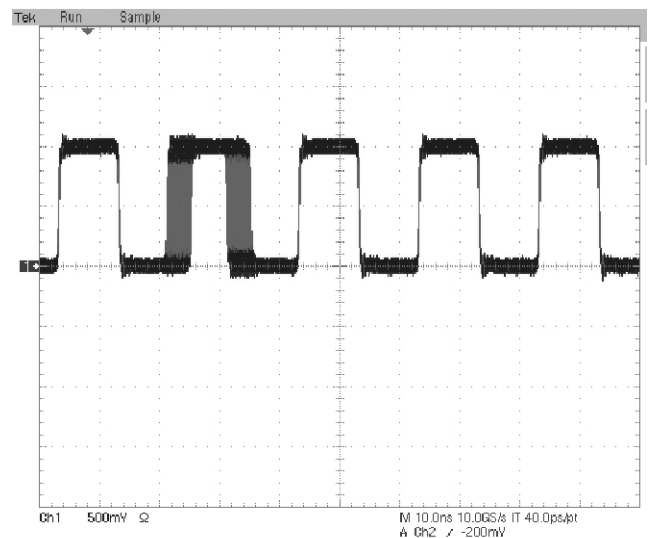

DTG5274

Figure 4-18: Jitter Generation example (partial)

DC Output This test verifies the DC output accuracy.

Equipment required	One digital multi-meter (item 2) Lead set for DC output (item 12)
Prerequisites	The DTG5000 Series Data Timing Generator must meet the prerequisites listed on page 4-11.

1. Attach the DC output lead set to the **DC output** connector at the front right side of DTG5000 series mainframe. See Figure 4-19.

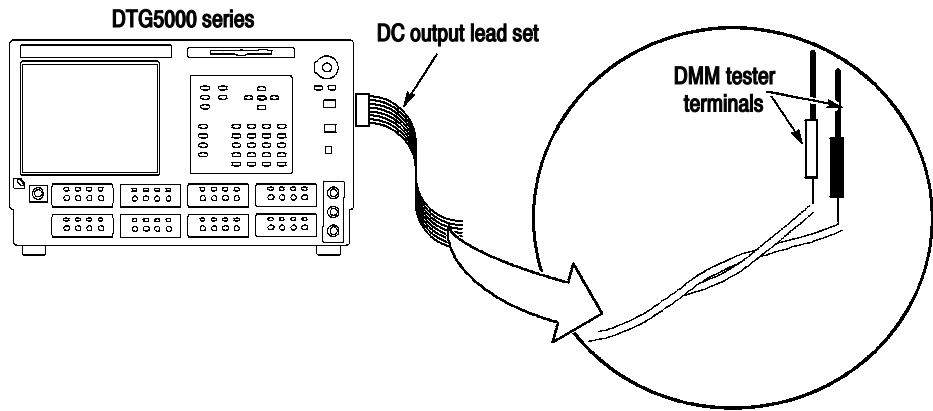

Figure 4-19: DC Output tests

2. Set the digital multi-meter controls:

Mode Direct Voltage
Range Auto

3. Load the setup file (DCOUT.dtg). Refer to *Loading Files* on page 4-13.
4. From the application menu bar, select **Settings**, and then select **DC Output**.
5. Move cursor to **Output On** box, and click the box to activate it.
6. Measure the potential difference for every channel:
 - a. Touch the DMM tester terminal to the metallic exposed pin of DC output lead set. The lead set is composed of eight twisted lines and each line has the one pin holder at the tip.

NOTE. Every channel has its own color, for example, CH1 is brown and CH5 is green. Touch the DMM terminal to the one channel color lead and then touch another tester terminal to the corresponding gray lead.

- b. Verify that all the measurement results are between 2.86 V and 3.14 V.
7. Modify the data timing generator settings:
- a. Change the **H Limit** of CH1 to 1.00 V.
 - b. Verify that the DMM reading is also 1.00 V.
 - c. Change the **H Limit** to 5 V.
 - d. Perform the same measurements as step 6-a while changing the Level as shown in the following table.

Level	DMM Range
- 3.00 V	- 3.14 V to - 2.86 V
- 2.00 V	- 2.11 V to - 1.89 V
- 1.00 V	- 1.08 V to - 0.92 V
0.00 V	- 0.05 V to 0.05 V
1.00 V	0.92 V to 1.08 V
2.00 V	1.89 V to 2.11 V
4.00 V	3.83 V to 4.17 V
5.00 V	4.80 V to 5.20 V

- e. Verify that the DMM readings are within the specified range.

Skew and Delay Timing

This test verifies that the skew and delay timing of the DTG5000 series mainframe are functional.

Equipment required	One sampling oscilloscope with a 80E03 sampling module (item 4) Two 50 Ω SMA coaxial cables (item 6) One SMA termination (item 16, DTGM30 only) One attenuator (item 17)
Prerequisites	The DTG5000 Series Data Timing Generator must meet the prerequisites listed on page 4-11. You must perform both the level and skew calibration before starting this test.

1. Install the test hookup and preset the instrument controls:
 - a. Hook up the oscilloscope:
 - Attach an attenuator to **CH1 input** of the 80E03 sampling module.
 - Connect an SMA coaxial cable from the **CH1** connector of output module, which is inserted in the slot A of DTG5000 series mainframe, to the **CH1 input** of the 80E03 sampling module.
 - Connect an SMA coaxial cable from the **SYNC OUT** at the front panel of DTG5000 series mainframe to the **Trigger Direct Input** of sampling oscilloscope. See Figure 4-20.
 - (DTGM30 only): If your output module is DTGM30, attach an SMA termination to the **CH1** connector of output module.

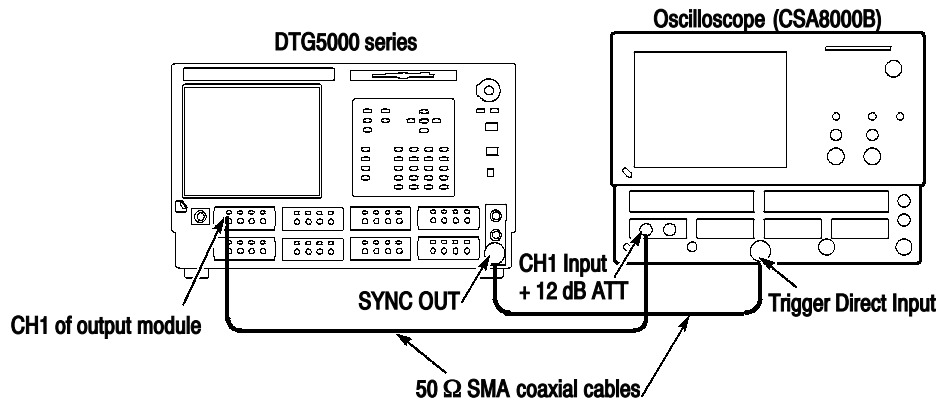

Figure 4-20: Delay timing tests

b. Set the oscilloscope controls as follows:

Vertical	
CH1 scale	200 mV/div (with 12 dB ATT) Select Setup -> Vertical -> External Attenuation , then set 12 dB.
Horizontal	
Scale	100 ps/div
Acquisition	
Mode	Average
Number of running averages	32
Trigger	
Source	External Direct
Slope	Positive
Level	Set to 50 %
Measurement	
Delay Time	
Select Meas	R1 (+) to C1 (+) Delay
Reference	Absolute + 500 mV (R1, C1)

2. Load the setup file (DELAY.dtg). Refer to *Loading Files* on page 4-13.
3. Verify that the **View by Channel** is selected in the View menu of data timing generator.
4. Push the **RUN** button of the data timing generator to light the RUN LED, and then push the **ALL OUTPUTS ON/OFF** to activate the output.
5. Adjust the oscilloscope position controls so the waveform is centered on the screen.
6. Do the following substeps:
 - a. Save the CH1 waveform of oscilloscope to Ref 1.
 - b. (DTGM10 and DTGM20): Disconnect the SMA cable from the **CH1** connector of the output module, and then connect it to CH2, CH3, and CH4 of output module that installed in the slot A.

(DTGM30 only): Disconnect the SMA cable from the **CH1** of the output module, and then connect it to **CH2** of the module that installed in the slot A. Remove the SMA termination from the **CH1** and attach it to **CH2**.
 - c. Record the **R1C1 Delay** measurement values.

- d. Calculate the skew between channels from the values of the **R1C1 Delay** measurements.
 - e. Repeat the measurements for other modules installed in the mainframe..
 - f. Verify that the measurement results are within the following range.
 - <100 ps (slot A, B, C, D of DTG5078, and DTG5274)
 - <200 ps (slot E, F, G, H of DTG5078)
7. Push the **TIMING** button at the front panel of DTG5000 series mainframe to display the Timing Window.
 8. Verify the instrument hookup: Confirm that the SMA cable is connected from the **CH1 input** of the 80E03 sampling module to the **CH1** connector of the output module which is inserted in the slot A of the mainframe. If your output module is DTGM30, attach an SMA termination to the **CH1** connector of output module.
 9. Do the following substeps to verify the Lead Delay accuracy.
 - a. Save the CH1 waveform of oscilloscope to Ref 1 at the DTG delay of 0.000 ns.
 - b. Verify that the **View by Channel** is selected in the View menu of data timing generator.
 - c. Move the cursor to **1-A1 Delay** on the data timing generator screen, and then increment the value by 2 ns from 0.000 ns to 10.000 ns.
 - d. Adjust the oscilloscope horizontal position control so the CH1 waveform (rising edge) is centered on the screen.
 - e. Modify the oscilloscope setting: Set Source 2 to Ch1 and Source 1 to Ref1.
 - f. Verify that the **R1C1 Delay** values are within the following range.
 - ± 100 ps of setup value (slot A, B, C, D of DTG5078, and DTG5274)
 - ± 150 ps of setup value (slot E, F, G, H of DTG5078)
 - g. Repeat the same measurements as step **9-b** through step **9-d** for other channels (see below), and verify that the measurement results are within the specified range.
 - (DTGM10 and DTGM20): Disconnect the SMA cable from the **CH1** connector of the output module, and then connect it to CH2, CH3, and CH4 of the output module.

- (DTGM30 only): Disconnect the SMA cable from the **CH1** connector of the output module, and then connect it to **CH2** of the output module. Remove the SMA termination from the **CH1** and attach it to **CH2** connector.
 - h. Repeat the measurements for other modules installed in the mainframe.
- 10. Change the **Delay** settings of all the channels to 0.000 ns, and then set the oscilloscope measurement function to **R1(+)** to **C1(-)** **Delay**.
- 11. Verify the instrument hookup: Confirm that the SMA cable is connected from the **CH1 input** of the 80E03 sampling module to the **CH1** connector of the output module which is inserted in the slot A of the mainframe. If your output module is DTGM30, attach an SMA termination to the **CH1** connector of output module.
- 12. Do the following substeps to verify the Trail Delay accuracy:
 - a. Save the CH1 waveform of oscilloscope to Ref 1 at the delay 0.000 ns.
 - b. Verify that the **View by Channel** is selected in the View menu of data timing generator.
 - c. Move the cursor to **1-A1 PW/Duty** on the data timing generator screen, and then increment the trail delay by 0.002000 μ s from 0.050000 μ s to 0.060000 μ s.
 - d. Adjust the oscilloscope horizontal position control so the CH1 waveform (falling edge) is centered on the screen.
 - e. Verify that the **R1C1 Delay** values are within the following range.
 - \pm 100 ps of setup value (slot A, B, C, D of DTG5078, and DTG5274)
 - f. Repeat the same measurements as step 12-b through step 12-d for other channels and other modules, and verify that the measurement results are within the specified range.

Clock Out Random Jitter

This test verifies the data timing generator clock out random jitter.

Equipment required	One sampling oscilloscope with a 80E03 sampling module (item 4) Two 50 Ω SMA coaxial cables (item 6) Two attenuators (item 17)
Prerequisites	The DTG5000 Series Data Timing Generator must meet the prerequisites listed on page 4-11.

1. Install the test hookup and preset the instrument controls:

a. Hook up the oscilloscope:

- Attach the attenuator to **CH1 input** of the 80E03 sampling module and to **Direct Trigger Input** of sampling oscilloscope.
- Connect an SMA coaxial cable from the **CLOCK OUT** at the rear panel of DTG5000 series mainframe to the **CH1 input** of the 80E03 sampling module.
- Connect an SMA coaxial cable from the **CLOCK OUT** at the front panel of DTG5000 series mainframe to the **Trigger Direct Input** of sampling oscilloscope. See Figure 4-21.

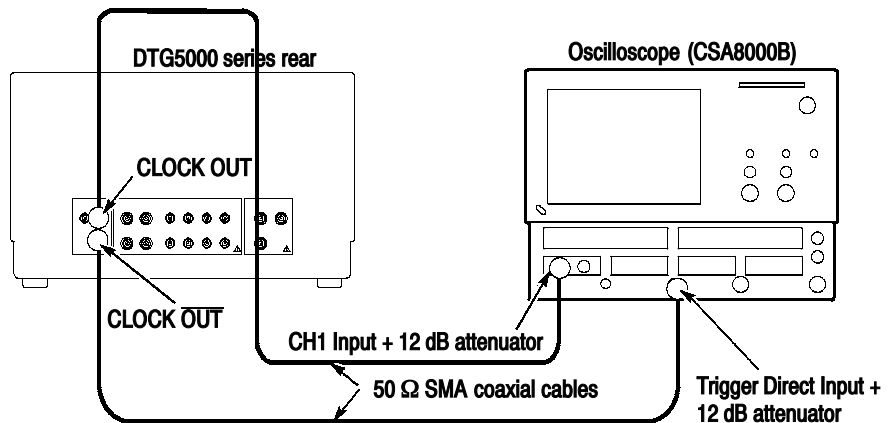

Figure 4-21: Clock out random jitter tests

b. Set the oscilloscope controls as follows:

Vertical	
CH1 scale	100 mV/div (with 12 dB ATT) Select Setup -> Vertical -> External Attenuation, then set 12 dB.
Horizontal	
Scale	200 ps/div (DTG5078) 50 ps/div (DTG5274)
Acquisition	
Mode	Sample
Trigger	
Source	External Direct
Slope	Positive
Level	Set to 50%

Display Infinite Persistence
 Measurement CH1 RMS Jitter
 Use Wfm Database
 Signal Type: Pulse

2. Load the setup file (RNDJIT.dtg). Refer to *Loading Files* on page 4-13.
3. Push the **RUN** button of the data timing generator to light the RUN LED, and then push the **ALL OUTPUTS ON/OFF** button to activate the output.
4. Verify that the oscilloscope displays the waveforms as shown in Figure 4-22 while adjusting the position and offset controls.

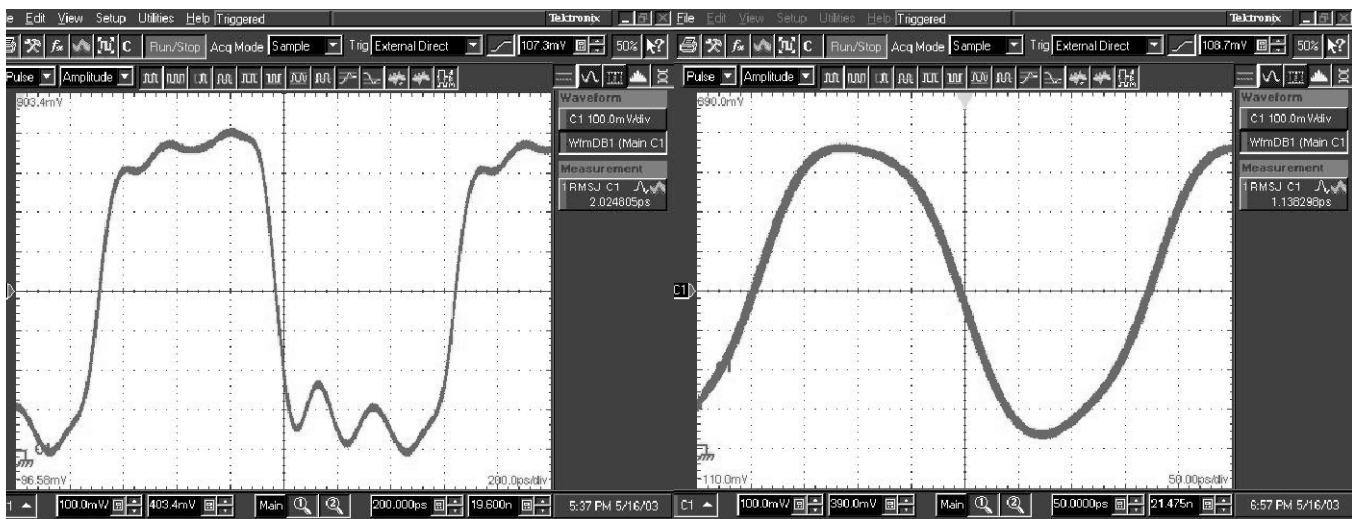

DTG5078

DTG5274

Figure 4-22: Clock out random jitter sample

5. Verify that the RMS jitter is within 3 ps.

Random Jitter This test verifies the data timing generator random jitter.

Equipment required	One sampling oscilloscope with a 80E03 sampling module (item 4) Two 50 Ω SMA coaxial cables (item 6) One SMA termination (item 16, DTG5274 only) Two attenuators (item 17)
Prerequisites	The DTG5000 Series Data Timing Generator must meet the prerequisites listed on page 4-11.

NOTE. When you perform this test, use the specified output module. If your mainframe is the DTG5274, use the DTGM30 output module. If your mainframe is the DTG5078, use the DTGM20 output module.

1. Install the test hookup and preset the instrument controls:
 - a. Hook up the oscilloscope:
 - Attach the attenuators to **CH1 input** and **Trigger Direct Input** of sampling oscilloscope.
 - Connect an SMA coaxial cable from the **CH1** connector of the output module, which is inserted in the slot A of DTG5000 series mainframe, to the **CH1 input** of the 80E03 sampling module.
 - Connect a second SMA coaxial cable from the **CLOCK OUT** at the rear panel of DTG5000 series mainframe to the **Trigger Direct Input** of sampling oscilloscope. See Figure 4-23.

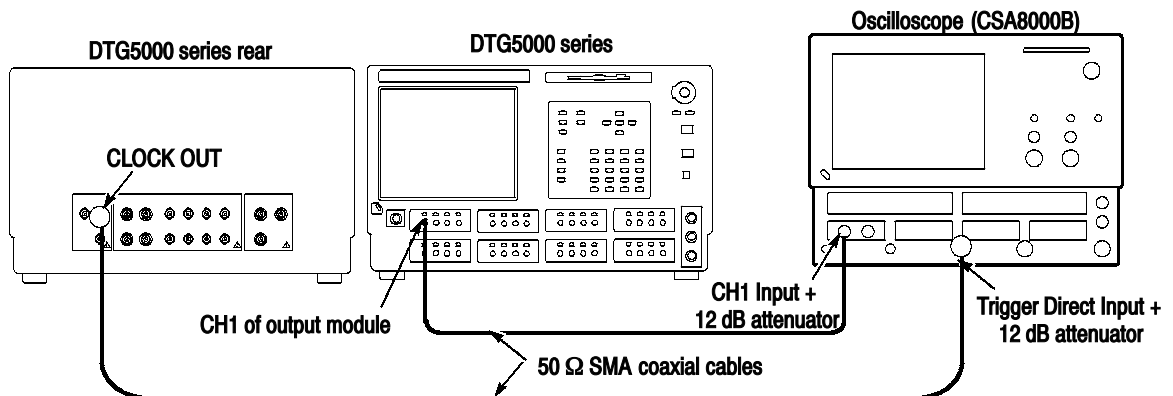
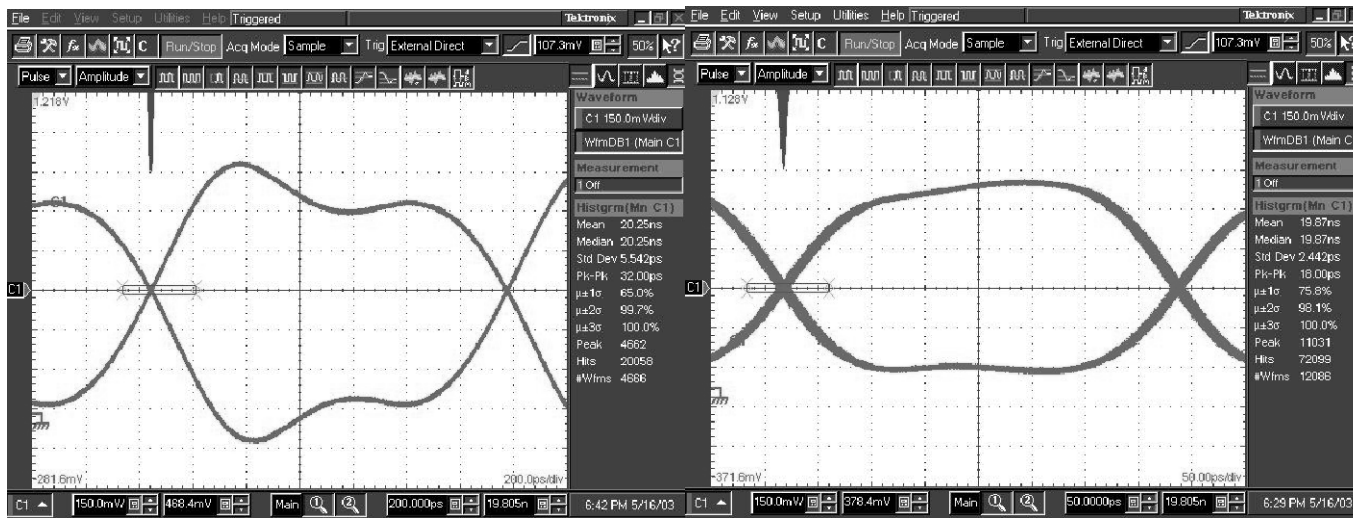

Figure 4-23: Random jitter tests

- (DTG5274 only): Attach an SMA termination to the **CH2 input** of sampling oscilloscope.
- b. Set the oscilloscope controls as follows:

Vertical	
CH1 and CH2 scale	150 mV/div (with 12 dB ATT) Select Setup -> Vertical -> External Attenuation , then set 12 dB .
Waveform CH1	On
Waveform CH2	Off
Horizontal	
Position	Approximately 20 ns
Scale	200 ps/div (DTG5078) 50 ps/div (DTG5274)
Acquisition	
Mode	Sample
Trigger	
Source	External Direct
Slope	Positive
Level	Set to 50%
Display	Infinite Persistence
Histogram	CH1 ON Turn the Enable Histogram check box on, select Horizontal radio button, select Histogram from Display Option, select Linear radio button, click Acq tab and select Condition from Stop After radio button, select Histogram Hits , and then input 8000 to the window.

2. Load the setup file (RNDJIT.dtg). Refer to *Loading Files* on page 4-13.
3. Push the **RUN** button of the data timing generator to light the RUN LED, and then push the **ALL OUTPUTS ON/OFF** button to activate the output.
4. Verify that the oscilloscope displays the waveforms as shown in Figure 4-24 while adjusting the position and offset controls.



DTG5078

DTG5274

Figure 4-24: Random jitter waveform sample

5. Center the eye pattern on screen:
 - a. Adjust the oscilloscope position controls to locate the eye pattern CH1 waveform on center of screen.
 - b. Adjust the vertical offset to center the waveform cross point on screen. See Figure 4-24.
6. Place the Histogram Window to the cross point where vertical width of the window is set to approximately 0.2 div.
7. Change the vertical scale to 20 mV/div and horizontal scale to 20 ps/div.
8. Adjust the horizontal position, vertical offset, and Histogram Window position if the Histogram Window is out of the cross point. Set the vertical width of the window to approximately 0.2 div.
9. Stop the acquisition at the hit count 8000. Verify that the RMS jitter values are within the following range.
 - a. Push **CLEAR DATA**, and then push **RUN/STOP** button.
 - b. Read the **Std Dev** value.
 - < 4 ps (DTG5078)
 - < 3 ps (DTG5274)
10. Repeat the same measurements for other channels.

Total Jitter This test verifies the data timing generator total jitter.

Equipment required	One sampling oscilloscope with a 80E03 sampling module (item 4) Two 50 Ω SMA coaxial cables (item 6) One SMA termination (item 16, DTG5274 only) Two attenuators (item 17)
Prerequisites	The DTG5000 Series Data Timing Generator must meet the prerequisites listed on page 4-11.

NOTE. When you perform this test, use the specified output module. If your mainframe is the DTG5274, use the DTGM30 output module. If your mainframe is the DTG5078, use the DTGM20 output module.

1. Install the test hookup and preset the instrument controls:
 - a. Hook up the oscilloscope:
 - Perform the same hookup procedures as the Random Jitter test described on page 4-50.
 - b. Set the oscilloscope controls as follows:

Vertical	
CH1 and CH2 scale	100 mV/div (with 12 dB ATT) Select Setup -> Vertical -> External Attenuation , then set 12 dB.
Waveform CH1	On
Waveform CH2	Off
Horizontal	
Position	Approximately 20 ns
Scale	200 ps/div (DTG5078) 50 ps/div (DTG5274)
Acquisition	
Mode	Sample
Trigger	
Source	External Direct
Slope	Positive
Level	Set to 50%
Display	Infinite Persistence
Measurement	CH1 RMS Jitter Use Wfm Database Signal Type: NRZ

2. Load the setup file (TOTJIT.dtg). Refer to *Loading Files* on page 4-13.
3. Push the **RUN** button of the data timing generator to light the RUN LED, and then push the **ALL OUTPUTS ON/OFF** button to activate the output.
4. Verify that the oscilloscope displays the waveforms as shown in Figure 4-25 while adjusting the position and offset controls.

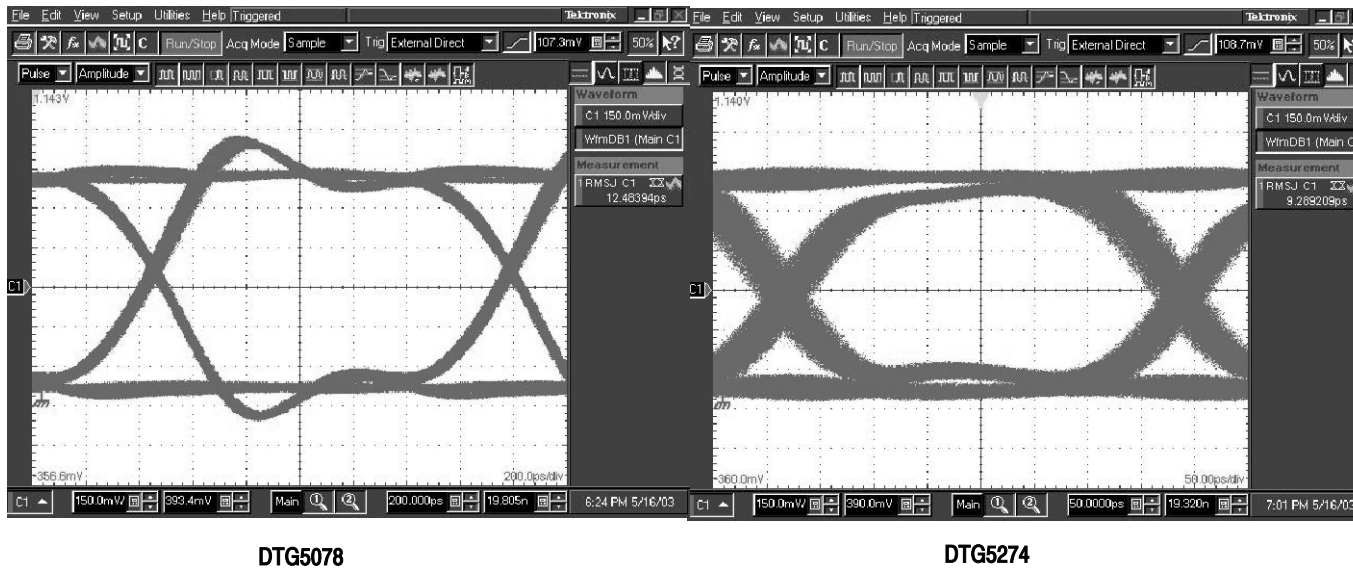

Figure 4-25: Total jitter waveform sample

5. Verify that the jitter rms values are within the following range.
 - < 18ps (DTG5078)
 - < 16ps (DTG5274)
6. Repeat the same measurements for other channels.

PG Mode

This test verifies that the PG Mode of the DTG5000 series mainframe is functional.

Equipment required	One oscilloscope (TDS7104) (item 3) Two 50 Ω SMA coaxial cables (item 6) Two SMA (female)-BNC (male) adapters (item 9)
Prerequisites	The DTG5000 Series Data Timing Generator DTG5000 Series Data Timing Generator must meet the prerequisites listed on page 4-11.

1. Install the test hookup and preset the instrument controls:

a. Hook up the oscilloscope:

- Attach SMA (female)-BNC (male) adapters to the oscilloscope **CH1 input** and **CH2 input** connectors.
- Connect an SMA coaxial cable from the **CH1** connector of the output module, which is inserted in the slot A of DTG5000 series mainframe, to the SMA-BNC adapter (CH1 input) of oscilloscope.
- Connect an SMA coaxial cable from the **CH2** connector of the output module, which is inserted in the slot A of DTG5000 series mainframe, to the SMA-BNC adapter (CH2 input) of oscilloscope. See Figure 4-26.

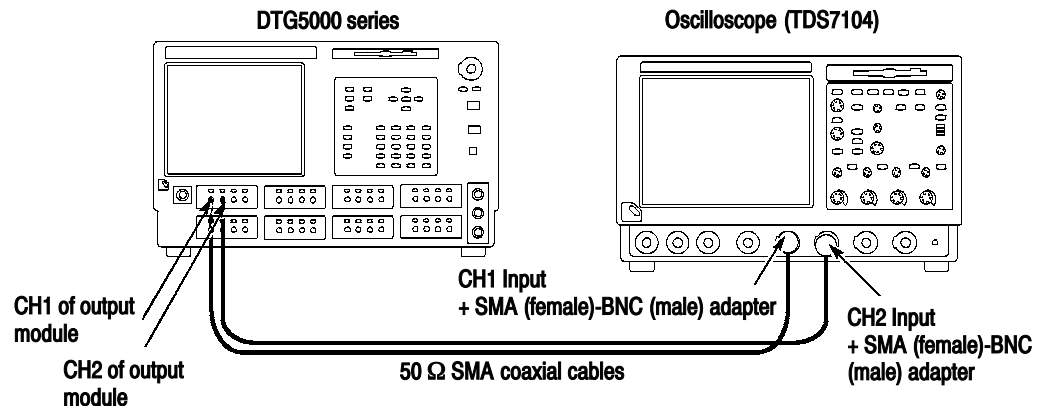

Figure 4-26: PG Mode tests

b. Set the oscilloscope controls as follows:

Vertical .	
CH1 and CH2 scale	500 mV/div
CH1 and CH2 input impedance . . .	50 Ω
Horizontal	
Scale	5 ns/div
Trigger	
Source	CH2
Slope	Positive
Level	0.5 V

2. Load the setup file (PGMODE.dtg). Refer to *Loading Files* on page 4-13.
3. Push the **RUN** button of the data timing generator to light the RUN LED, and then push the **ALL OUTPUTS ON/OFF** button to activate the output.
4. Verify that 100 MHz square waveform is displayed on the oscilloscope screen.
5. Verify the PG mode functions:
 - a. Push the **TIMING** button at the front panel of DTG5000 series mainframe to display the Timing Window.
 - b. Move the cursor to **Frequency** and change the frequency to 200 MHz.
 - c. Verify that the frequency readout of displayed waveform is 200 MHz on the oscilloscope screen.
 - d. Return the **Frequency** to 100 MHz, and then set the DTG5000 series mainframe slot A **CH1 DELAY** to 0.0020000 μ s.
 - e. Verify on the oscilloscope screen that the rising edge of CH1 is delayed by approximately 2 ns compared to CH2 rising edge.
6. Verify the CH1 duty:
 - a. Change the slot A **CH1 Duty** to 30%.
 - b. Verify on the oscilloscope screen that CH1 Duty of displayed waveform also indicates approximately 30%.
 - c. Change the **CH1 Duty** to 50%, and then change the slot A **CH1 Polarity** to **Invert**.
 - d. Verify on the oscilloscope screen that the displayed waveform is inverted.
7. (DTGM10 and DTGM20 only):
 - a. Push the **RUN** button of DTG5000 series mainframe to light the RUN LED.
 - b. Move cursor to **Slew Rate** with the TAB key.
 - c. Decrease the slew rate value by rotating the rotary encoder counterclockwise.
 - d. Verify the displayed waveform: Confirm that the rising edge becomes slow on the oscilloscope screen.

Master-Slave Operation

This test verifies that the Master-Slave operation of the DTG5000 series mainframe is functional.

Equipment required	One oscilloscope (TDS7104) (item 3) Two 50 Ω SMA coaxial cables (item 6) Two 50 Ω BNC coaxial cables (item 7) Two SMA (male)-BNC (female) adapters (item 8)
Prerequisites	The DTG5000 Series Data Timing Generator must meet the prerequisites listed on page 4-11.

1. Install the test hookup and preset the instrument controls:

a. Hook up the oscilloscope:

- Use an SMA coaxial cable to connect **CLK IN** and **CLK OUT1** of the Master/Slave Connection plate at the rear panel of DTG5000 series mainframe.
- Use a second SMA coaxial cable to connect $\overline{\text{CLK IN}}$ and $\overline{\text{CLK OUT1}}$ of the Master/Slave Connection plate at the rear panel of DTG5000 series mainframe.
- Attach an SMA (male)-BNC (female) adapter to the **CLOCK OUT** at the rear panel of DTG5000 series mainframe.
- Connect a BNC coaxial cable from the **CLOCK OUT** to the **CH1 input** of oscilloscope through an SMA-BNC adapter.
- Attach an SMA (male)-BNC (female) adapter to the **CH1** connector of the output module, which is inserted in the slot A of DTG5000 series mainframe.
- Connect a BNC coaxial cable from the **CH1** connector of output module to the **CH2 input** of oscilloscope through an SMA-BNC adapter. See Figure 4-27.

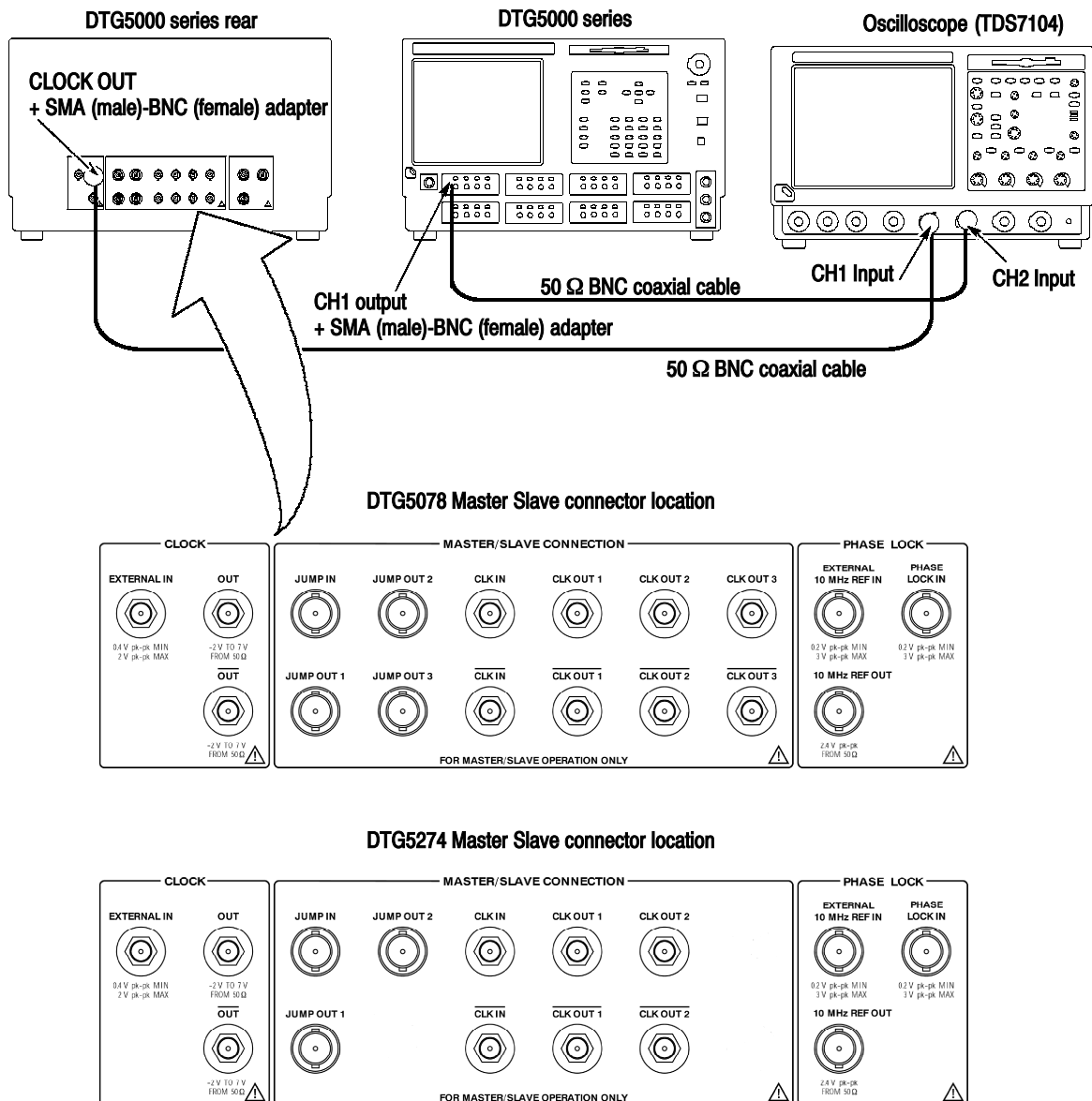

Figure 4-27: Master-Slave operation tests

b. Set the oscilloscope controls as follows:

Vertical .

CH1 and CH2 scale 500 mV/div

CH1 and CH2 input impedance . . . 50 Ω

Horizontal

Scale 50 ns/div

Trigger
 Source CH2
 Slope Positive
 Level + 0.5 V

2. Set the data timing generator controls and load the setup file:
 - a. Exit the DTG software.

NOTE. Move the cursor to the bottom left corner of the screen to get the Windows Start menu. Or, press the **CTRL** and **ESC** keys simultaneously to open the Windows Start menu.

- b. From the Windows **Start** menu, select **Programs**, select **Tektronix**, select **DTG5000**, and then select **DTG5000 Configuration Utility**. See Figure 4-28.

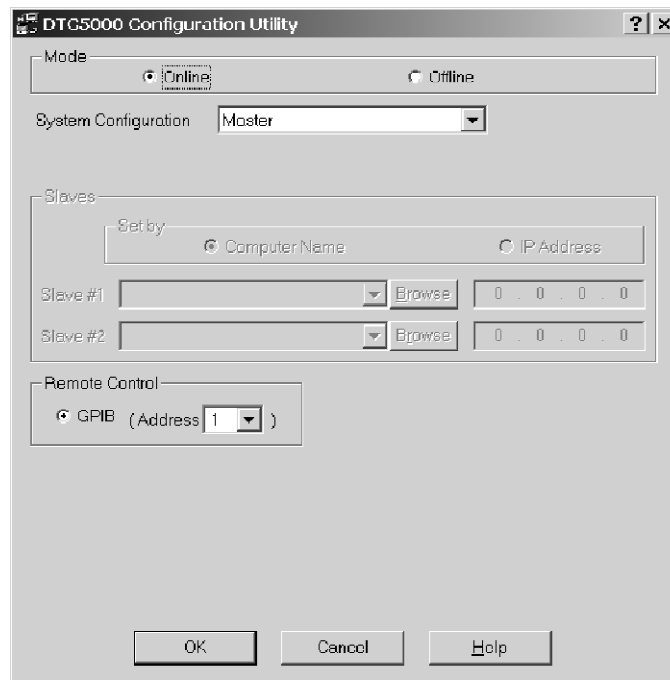
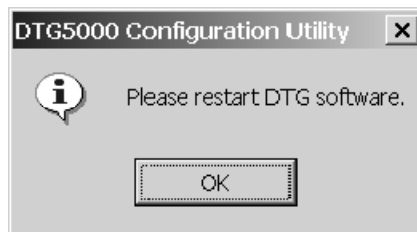

Figure 4-28: DTG5000 Configuration Utility dialog

- c. Confirm that **Online** is selected in the **Mode** box.
 - d. Select **Master/Slave#1** from the System Configuration pull-down menu.

- e. Select **IP Address** at the **Slaves Set by** check box, and then enter **0.0.0.0** to the IP Address box.
- f. Click **OK** to exit the window. The following dialog box appears and asks you to restart the DTG software.



- g. Click **OK**, and then restart the DTG software.
 - h. Load the setup file (**MASTER.dtg**). Refer to *Loading Files* on page 4-13.
3. Push the **RUN** button of the data timing generator to light the **RUN LED**, and then push the **ALL OUTPUTS ON/OFF** button to activate the output.
 4. Confirm that the oscilloscope displays the waveforms such as shown in Figure 4-29.

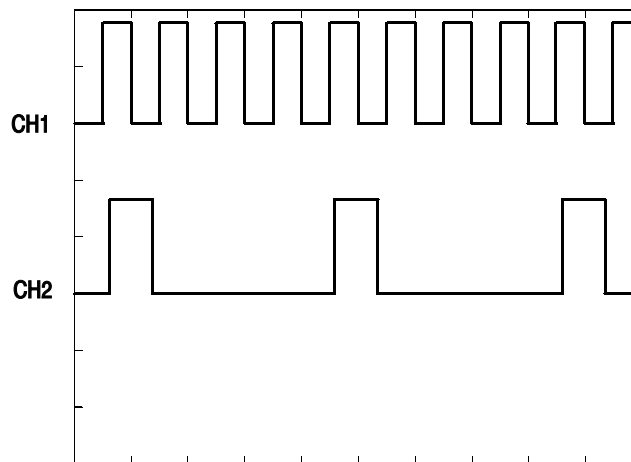

Figure 4-29: Master-Slave operation waveform sample

5. Disconnect the SMA cables from the **CLK OUT1** and **CLK OUT1**. Reconnect the cables to **CLK OUT2** and **CLK OUT2**, respectively.

6. Verify that the oscilloscope displays the same waveforms as step 4 on the screen.
7. (DTG5078 only): Disconnect the SMA cables from the **CLK OUT2** and **CLK OUT2**. Reconnect the cables to **CLK OUT3** and **CLK OUT3**, respectively. Verify that the oscilloscope displays the same waveforms as step 4 on the screen.
8. Before proceeding with the next test item, do the following substeps.
 - a. Exit the DTG software.

NOTE. *Mover cursor to the button left corner of the screen to get the Windows Start menu. Or, press the CTRL + ESC keys simultaneously to open the Start menu.*

- b. From the Windows **Start** menu, select **Programs**, select **Tektronix**, select **DTG5000**, and then select **DTG5000 Configuration Utility**. See Figure 4-28 on page 4-59.
- c. Select **Master** from the System Configuration pull-down menu.
- d. Click **OK** to exit the window. The dialog box appears and asks you to restart the DTG software. Click **OK**, and then restart the DTG software.

Output Module

The following procedures check those characteristics that relate to the output modules that are checked under *Output Module* in *Specifications*. Refer to page 1-30.

NOTE. *When you perform the DTG5000 series output module performance tests, you can install the module to any slot of mainframe.*

There are three types of output modules: DTGM10, DTGM20, and DTGM30. The same performance test procedures are applied to these modules, however, each module has different specifications.

Data Output DC Level

This test verifies the data output DC level accuracy of the DTG5000 series output module.

Equipment required	One digital multi-meter (item 2) One 50 Ω BNC coaxial cable (item 7) One SMA (male)-BNC (female) adapter (item 8) One BNC (female)- dual banana plug (item 13) One Feed-through 50 Ω termination (item 15)
Prerequisites	The DTG5000 Series Data Timing Generator must meet the prerequisites listed on page 4-11.

1. Install the test hookup and preset the instrument controls:

a. Hook up the digital multi-meter:

- Attach a BNC (female)-dual banana adapter to the digital multi-meter input connector, and then attach a 50 Ω termination to the BNC-dual banana adapter.
- Attach an SMA (male)-BNC (female) adapter to the **CH1** connector of the output module, which is inserted in the slot A of DTG5000 series mainframe.
- Connect a BNC coaxial cable from the SMA-BNC adapter (CH1 output of output module) to the 50 Ω termination of digital multi-meter. See Figure 4-30.

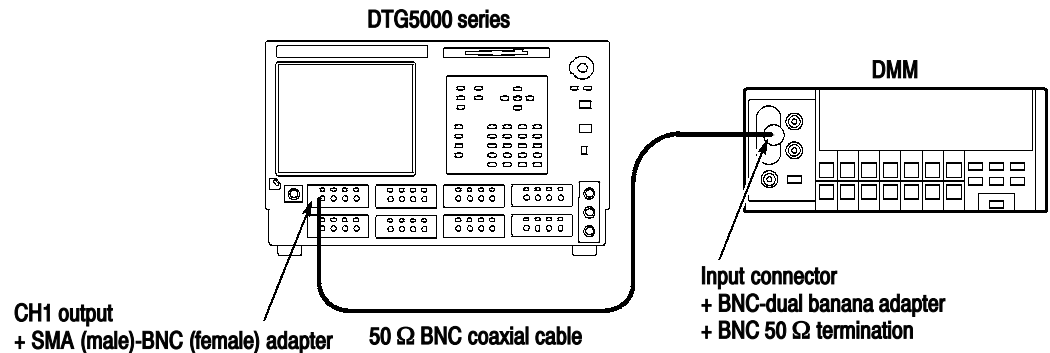

Figure 4-30: Data output DC level tests

b. Set the digital multi-meter controls:

Mode	Direct Voltage
Range	Auto

2. If you want to perform the data output DC level tests for DTGM10 or DTGM20, continue the following steps. If your output module is DTGM30, jump to step 5.
3. Do the following substeps to perform the high/low level voltage measurements:
 - a. Load the setup file (OM_H.dtg). Refer to *Loading Files* on page 4-13.
 - b. Push the **RUN** button of the data timing generator to light the **RUN LED**, and then push the **ALL OUTPUTS ON/OFF** button to activate the output.
 - c. Push the **LEVEL** button to set the high level and corresponding low level voltage for the CH1 output as shown in Table 4-4 (DTGM10) or Table 4-6 (DTGM20).
 - d. Verify that the DMM readings are within the voltage limits.
 - e. Load the setup file (OM_L.dtg). Refer to *Loading Files* on page 4-13.
 - f. Push the **LEVEL** button to set the low level and corresponding high level voltage for the CH1 output as shown in Table 4-5 (DTGM10) or Table 4-7 (DTGM20).
 - g. Verify that the DMM readings are within the voltage limits.

4. Change the connections and repeat the measurements:
 - a. Change the connection of BNC cable from the CH1 output to CH2, CH3, and CH4 output.
 - b. Perform the same measurements as step 3 for every channel.
 - c. Verify that the high level and low level measurements are within the specified voltage limits.

Table 4-4: DTGM10 High Level Voltage Accuracy

Setup value		High Level Output Voltage Limits
High Level Voltage	Low Level Voltage	
- 1.0 V	- 1.5 V	- 1.08 V to - 0.92 V
0 V	- 1.5 V	- 0.05 V to + 0.05 V
1 V	- 1.5 V	0.92 V to 1.08 V
2 V	- 1.5 V	1.89 V to 2.11 V

Table 4-5: DTGM10 Low Level Voltage Accuracy

Setup value		Low Level Output Voltage Limits
Low Level Voltage	High Level Voltage	
- 1.0 V	2.0 V	- 1.08 V to - 0.92 V
0 V	2.0 V	- 0.05 V to + 0.05 V
1 V	2.0 V	0.92 V to 1.08 V
1.75 V	2.0 V	1.6475 V to 1.8525 V

Table 4-6: DTGM20 High Level Voltage Accuracy

Setup value		High Level Output Voltage Limits
High Level Voltage	Low Level Voltage	
- 0.9 V	- 1.0 V	- 0.977 V to - 0.823 V
0 V	- 1.0 V	- 0.05 V to + 0.05 V
1.0 V	- 1.0 V	0.92 V to 1.08 V
2.0 V	- 1.0 V	1.89 V to 2.11 V

Table 4-7: DTGM20 Low Level Voltage Accuracy

Setup value		Low Level Output Voltage Limits
Low Level Voltage	High Level Voltage	
- 1.0 V	2.5 V	- 1.08 V to - 0.92 V
0 V	2.5 V	- 0.05 V to + 0.05 V
1.0 V	2.5 V	0.92 V to 1.08 V
2.0 V	2.5 V	1.89 V to 2.11 V

5. Do the following substeps to perform the high/low level voltage measurements for the DTGM30:
 - a. Load the setup file (OM_H.dtg). Refer to *Loading Files* on page 4-13.
 - b. Push the **RUN** button of the data timing generator to light the RUN LED, and then push the **ALL OUTPUTS ON/OFF** button to activate the output.
 - c. Push the **LEVEL** button to set the high level and corresponding low level voltage for the CH1 output as shown in Table 4-8. Verify that the DMM reading is within the voltage limits.
 - d. Load the setup file (OM_L.dtg). Refer to *Loading Files* on page 4-13.
 - e. Push the **LEVEL** button to set the low level and corresponding high level voltage for the CH1 output as shown in Table 4-9. Verify that the DMM reading is within the voltage limits.
6. Change the connections and repeat the measurements:
 - a. Change the connection of BNC cable from the CH1 output to CH2, CH1, and CH2 output.
 - b. Perform the same measurements as step 5 for every channel.
 - c. Verify that the high level and low level measurements are within the specified voltage limits.

NOTE. When you perform the voltage measurements for $\overline{CH1}$ and $\overline{CH2}$, load the setup file *OM_L.dtg* for high level measurements and *OM_H.dtg* for low level measurements.

Table 4-8: DTGM30 High Level Voltage Accuracy

Setup value		High Level Output Voltage Limits
High Level Voltage	Low Level Voltage	
- 0.97 V	- 1.0 V	- 1.0491 V to - 0.8909 V
0.5 V	- 0.75 V	0.435 V to 0.565 V
2.0 V	1.50 V	1.89 V to 2.11 V
2.47 V	2.44 V	2.3459 V to 2.5941 V

Table 4-9: DTGM30 Low Level Voltage Accuracy

Setup value		Low Level Output Voltage Limits
Low Level Voltage	High Level Voltage	
- 1.0 V	0.25 V	- 1.08 V to - 0.92 V
0.5 V	1.50 V	0.435 V to 0.565 V
2.0 V	2.25 V	1.89 V to 2.11 V
2.44 V	2.47 V	2.3168 V to 2.5632 V

Data Format This test verifies that the data format of the DTG5000 series mainframe is functional.

Equipment required	One oscilloscope (TDS7104) (item 3) Two 50 Ω SMA coaxial cables (item 6) Two SMA (female)-BNC (male) adapters (item 9)
Prerequisites	The DTG5000 Series Data Timing Generator must meet the prerequisites listed on page 4-11.

1. Install the test hookup and preset the instrument controls:
 - a. Hook up the oscilloscope:
 - Attach SMA (female)-BNC (male) adapters to the oscilloscope **CH1** and **CH2** input connectors.
 - Connect an SMA coaxial cable from the **CH1** connector of the output module, which is inserted in the slot A of DTG5000 series mainframe, to the SMA-BNC adapter (CH1 input) of oscilloscope.
 - Connect an SMA coaxial cable from the **CH2** connector of the output module, which is inserted in the slot A of DTG5000 series mainframe, to the SMA-BNC adapter (CH2 input) of oscilloscope. See Figure 4-31.

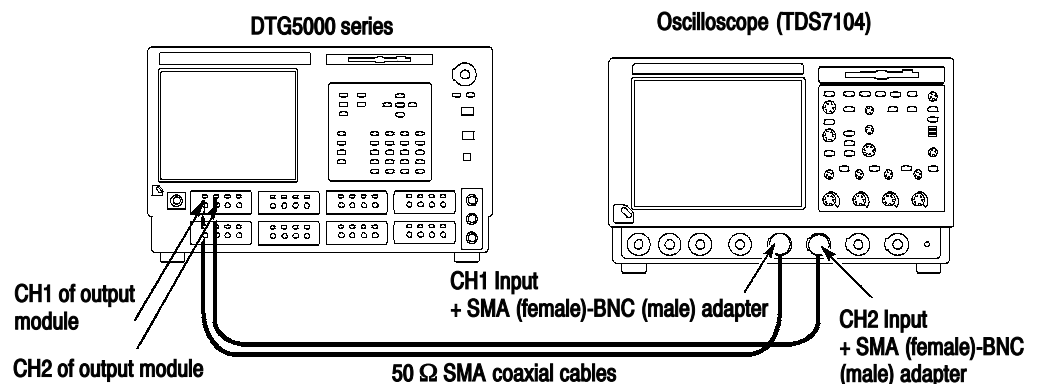

Figure 4-31: Data format tests

- b. Set the oscilloscope controls as follows:

Vertical .
CH1 and CH2 scale 500 mV/div
CH1 and CH2 input impedance ... 50 Ω

Horizontal
Scale 40 ns/div

Trigger
Source CH2
Slope Positive
Level 0.5 V

- 2. Load the setup file (FORMAT.dtg). Refer to *Loading Files* on page 4-13.

- 3. Do the following substeps to verify the data format:

- a. Push the **RUN** button of the data timing generator to light the RUN LED, and then push the **ALL OUTPUTS ON/OFF** button to activate the output.
- b. Verify that the oscilloscope displays pulse pattern such as shown in Figure 4-32.

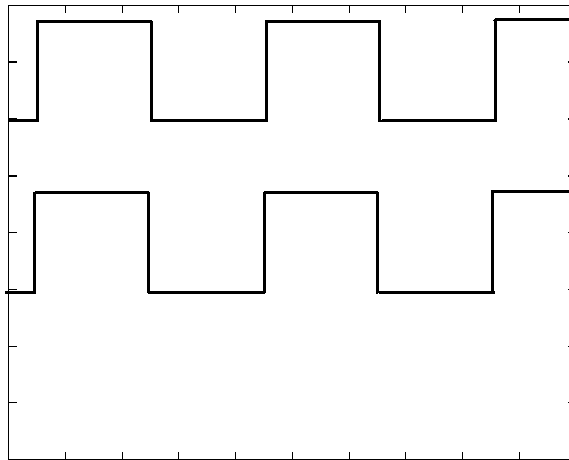

Figure 4-32: Pulse pattern example

- c. Push the **TIMING** button at the front panel of DTG5000 series mainframe to display the Timing Window.

- d. Change **CH1 Format** of slot A from **NRZ** to **RZ**. Verify that the displayed waveform is changed from Figure 4-32 to Figure 4-33.

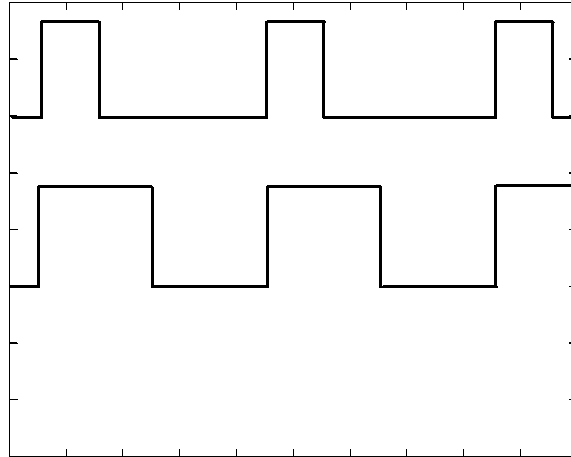

Figure 4-33: RZ waveform example

- e. Change **CH1 Format** of slot A from **RZ** to **R1**. Verify that the displayed waveform is changed from Figure 4-33 to Figure 4-34.

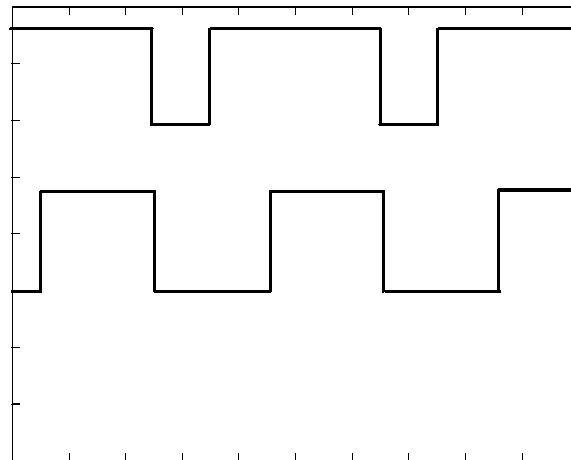

Figure 4-34: R1 waveform example



Adjustment Procedures



Adjustment Procedures

There are no adjustments. All boards are adjusted when they are shipped from the factory.



Maintenance

Maintenance

This section contains the information needed to do periodic and corrective maintenance on the DTG5000 Series data timing generator.

The following subsections are included:

- **Related Maintenance Procedures** — Provides information about various sections that have related maintenance information.
- **Preparation** — Introduction plus general information on preventing damage to internal modules when doing maintenance.
- **Inspection and Cleaning** — Information and procedures for inspecting the data timing generator and cleaning its external and internal modules.
- **Removal and Installation Procedures** — Procedures for the removal of defective modules and replacement of new or repaired modules.
- **Troubleshooting** — Information for isolating failed modules. Included are instructions for operating the internal diagnostic routines of the data timing generator and troubleshooting trees. Most of the trees make use of these internal diagnostic routines to speed fault isolation to a module.
- **System recovery** — Information for software installation. When operating system does not start up, you may have to reinstall the operating system for recovery. This section includes information for reinstalling the operating system, setting up the operating system and reinstalling the DTG5000 software.
- **Service Password** — Information for registration of serial number.

Related Maintenance Procedures

The following sections contain information and procedures related to maintenance.

- The *Operating Information* section covers instructions useful when you try to troubleshoot. It also details the service strategy and lists options for obtaining maintenance service and for replacing failed modules.
- The *Theory of Operation* section contains a circuit description at the module, or block, level.
- The *Performance Verification* section contains procedures that may be useful in isolating problems to modules by testing product performance.

- The *Diagrams* section contains a block diagram using individual modules as blocks and an interconnection diagram showing connections between the modules.
- The *Replaceable Mechanical Parts* section, lists all field replaceable modules by part number.

Preparation

Before servicing this product, read the *Safety Summary* and *Introduction* at the front of the manual and the ESD information below.



CAUTION. *Static discharge can damage any semiconductor component in this generator.*

NOTE. *If you are removing a module for service, begin by doing the Access Procedure procedure on page 6-15. By following the instructions in that procedure, you remove the module to be serviced while removing the minimum number of additional modules.*

Preventing ESD

When performing any service which requires internal access to the data timing generator, adhere to the following precautions to avoid damaging internal modules and their components due to electrostatic discharge (ESD).

1. Minimize handling of static-sensitive modules.
2. Transport and store static-sensitive modules in their static protected containers or on a metal rail. Label any package that contains static-sensitive modules.
3. Discharge the static voltage from your body by wearing a grounded antistatic wrist strap while handling these modules. Do service of static-sensitive modules only at a static-free work station.
4. Do not allow anything capable of generating or holding a static charge on the work station surface.
5. Handle circuit boards by the edges when possible.
6. Do not slide the modules over any surface.
7. Avoid handling modules in areas that have a floor or work-surface covering capable of generating a static charge.

Susceptibility to ESD

Table 6-1 lists the relative susceptibility of various classes of semiconductors. Static voltages of 1 kV to 30 kV are common in unprotected environments.

Table 6-1: Relative susceptibility to static-discharge damage

Semiconductor classes	Relative susceptibility levels ¹
MOS or CMOS microcircuits or discrete circuits, or linear microcircuits with MOS inputs (most sensitive)	1
ECL	2
Schottky signal diodes	3
Schottky TTL	4
High-frequency bipolar transistors	5
JFET	6
Linear microcircuits	7
Low-power Schottky TTL	8
TTL (least sensitive)	9

¹ Voltage equivalent for levels (voltage discharged from a 100 pF capacitor through resistance of 100 ohms):

1 = 100 to 500 V	6 = 600 to 800 V
2 = 200 to 500 V	7 = 400 to 1000 V (est.)
3 = 250 V	8 = 900 V
4 = 500 V	9 = 1200 V
5 = 400 to 600 V	

Inspection and Cleaning

Inspection and Cleaning describes how to inspect for dirt and damage. It also describes how to clean the exterior and interior of the DTG5000 Series data timing generators. Inspection and cleaning are done as preventive maintenance. Preventive maintenance, when done regularly, may prevent data timing generator malfunctions and enhance its reliability.

Preventive maintenance consists of visually inspecting and cleaning the data timing generator and using general care when operating it.

How often to do maintenance depends on the severity of the environment in which the data timing generator is used. A proper time to perform preventive maintenance is just before generator adjustment.

General Care

The cabinet helps keep dust out of the data timing generator and should normally be in place when operating the generator. The front cover protects the front-panel and display from dust and damage. Install the front cover when storing or transporting the data timing generator.

Inspection and Cleaning Procedures

Inspect and clean the data timing generator as often as operating conditions require. The collection of dirt on components inside can cause them to overheat and breakdown. (Dirt acts as an insulating blanket, preventing efficient heat dissipation.) Dirt also provides an electrical conduction path that could cause a generator failure, especially under high-humidity conditions.



CAUTION. *Avoid the use of chemical cleaning agents which might damage the plastics used in this DTG5000 Series data timing generator. Use only deionized water when cleaning the front-panel buttons. Use an ethyl alcohol solution as a cleaner and rinse with deionized water. Before using any other type of cleaner, consult your Tektronix Service Center or representative.*

Inspection — Exterior. Inspect the outside of the generator for damage, wear, and missing parts, using Table 6-2 as a guide. Data timing generators that appear to have been dropped or otherwise abused should be checked thoroughly to verify correct operation and performance. Immediately repair defects that could cause personal injury or cause further data timing generator damage.

Table 6-2: External inspection check list

Item	Inspect for	Repair action
Cabinet, front-panel, and cover	Cracks, scratches, deformations, damaged hardware or gaskets.	Repair or replace defective module.
Front-panel knobs	Missing, damaged, or loose knobs.	Repair or replace missing or defective knobs.
Connectors	Broken shells, cracked insulation, and deformed contacts. Dirt in connectors.	Repair or replace defective modules. Clear or wash out dirt.
Carrying handle, bail, cabinet feet.	Correct operation.	Repair or replace defective module.
Accessories	Missing items or parts of items, bent pins, broken or frayed cables, and damaged connectors.	Repair or replace damaged or missing items, frayed cables, and defective modules.

Cleaning Procedure — Exterior. Do the following steps to clean the data timing generator exterior:

1. Remove loose dust on the outside of the data timing generator with a lint free cloth.
2. Remove remaining dirt with a lint free cloth dampened in a general purpose detergent-and-water solution. Do not use abrasive cleaners.
3. Clean the light filter protecting the monitor screen with a lint-free cloth dampened with either ethyl alcohol or, preferably, a gentle, general purpose detergent-and-water solution.



CAUTION. To prevent getting moisture inside the generator during external cleaning, use only enough liquid to dampen the cloth or applicator.

Inspection — Interior. To access the inside of the data timing generator for inspection and cleaning, refer to the *Removal and Installation Procedures* in this section.

Inspect the internal portions of the data timing generator for damage and wear, using Table 6-3 as a guide. Defects found should be repaired immediately.



CAUTION. To prevent damage from electrical arcing, ensure that circuit boards and components are dry before applying power to the data timing generator .

Table 6-3: Internal inspection check list

Item	Inspect for	Repair action
Circuit boards	Loose, broken, or corroded solder connections. Burned circuit boards. Burned, broken, or cracked circuit-run plating.	Remove failed module and replace with a new module.
Resistors	Burned, cracked, broken, blistered condition.	Exchange of a new circuit board unit.
Solder connections	Cold solder or rosin joints.	Resolder joint and clean with ethyl alcohol.
Capacitors	Damaged or leaking cases. Corroded solder on leads or terminals.	Exchange of a new circuit board unit.
Semiconductors	Loosely inserted in sockets. Distorted pins.	Firmly seat loose semiconductors. Remove devices that have distorted pins. Carefully straighten pins (as required to fit the socket), using long-nose pliers, and reinsert firmly. Ensure that the straightening action does not crack pins, causing them to break off.
Wiring and cables	Loose plugs or connectors. Burned, broken, or frayed wiring.	Firmly seat connectors. Repair or replace modules with defective wires or cables.
Chassis	Dents, deformations, and damaged hardware.	Straighten, repair, or replace defective hardware.

Cleaning Procedure — Interior. Do the following steps to clean the generator interior:

1. Blow off dust with dry, low-pressure, deionized air (approximately 9 psi).
2. Remove any remaining dust with a lint-free cloth dampened in isopropyl alcohol (75% solution) and rinse with warm deionized water. (A cotton-tipped applicator is useful for cleaning in narrow spaces and on circuit boards.)

NOTE. *If steps 1 and 2 do not remove all the dust or dirt, please contact your local Tektronix service or Beaverton service center.*

Lubrication. There is no periodic lubrication required for the data timing generator.

Removal and Installation Procedures

This subsection contains procedures for removal and installation of mechanical and electrical modules. Any electrical or mechanical module, assembly, or part listed in the *Replaceable Mechanical Parts* section of this manual is a module.

Preparation for Use



WARNING. *Before doing this or any other procedure in this manual, read the Safety Summary at the beginning of this manual. Also, to prevent possible injury to service personnel or damage to components, read Operating Information: Installation and Preventing ESD in this section.*

This subsection contains the following items:

- This preparatory information that you need to properly do the procedures that follow.
- A list of tools that are required to remove and disassemble all modules.
- Three module-locator diagrams for finding the External Modules (see Figure 6-2), Front-Panel and Display Modules (see Figure 6-3), and Inner-Chassis Modules (see Figure 6-4 and Figure 6-5).
- Procedures for removal and installation of the electrical and mechanical modules.
- A disassembly procedure for removal of all the major modules from the data timing generator at one time and for reassembly of those modules. A complete disassembly is normally only done when completely cleaning the data timing generator. (Instructions for doing the actual cleaning are found under *Inspection and Cleaning* at the beginning of this section.)



WARNING. *To prevent serious injury or death, disconnect the power cord from the line voltage source before doing any procedure in this subsection.*

Summary of Procedures

The following procedures are described in the order in which they appear in this section.

- The *Access Procedure* on page 6-15 directs you to the procedure(s) (if any) that are required to access the module to be serviced, and then it directs you to the procedure to remove that module.
- *Procedures for External Modules* on page 6-16 are procedures for removing modules that do not require internal access to the data timing generator.
- *Procedures for Internal Modules (Lower)* on page 6-31 are procedures for removing modules which require access to the internal lower part of the data timing generator chassis.
- *Procedures for Internal Modules (Upper)* on page 6-38 are procedures for removing modules which require access to the internal upper part of the data timing generator chassis.

Equipment Required. Most modules in the data timing generator can be removed using a screwdriver with a #2 Phillips tip (see Table 6-4). Use this tool whenever a procedure step instructs you to remove or install a screw unless a different size screwdriver is specified in that step. All equipment required to remove and install a module are listed in the first step of each procedure.

Table 6-4: Tools required for module removal

Item no.	Name	Description
1	Screwdriver handle	Accepts Phillips-driver bits
2	#1 Phillips tip	Phillips-driver bit for #1 screw size
3	#2 Phillips tip	Phillips-driver bit for #2 screw size
4	Flat-blade screwdriver	Screwdriver for removing slotted screws
5	Needle-Nose Pliers	Standard tool
6	Nutdriver, 1/2 inch	Standard tool
7	Nutdriver, 5 mm	Standard tool
8	Nutdriver, 7 mm	Standard tool
9	Retaining Ring Pliers	Standard tool
10	Angle-Tip Tweezers	Standard tool
11	Pliers	Standard tool
12	Cable remover	U.FL cable remover by HIROSE
13	Soldering Iron	Standard tool
14	Solder Wick	Standard tool
15	Adhesive	TRA-CON: Tra-Bond #BA-2114

Instrument Orientation The procedures refer to “front,” “right,” “top,” and so on. of the data timing generator. Figure 6-1 shows how the sides are referenced.

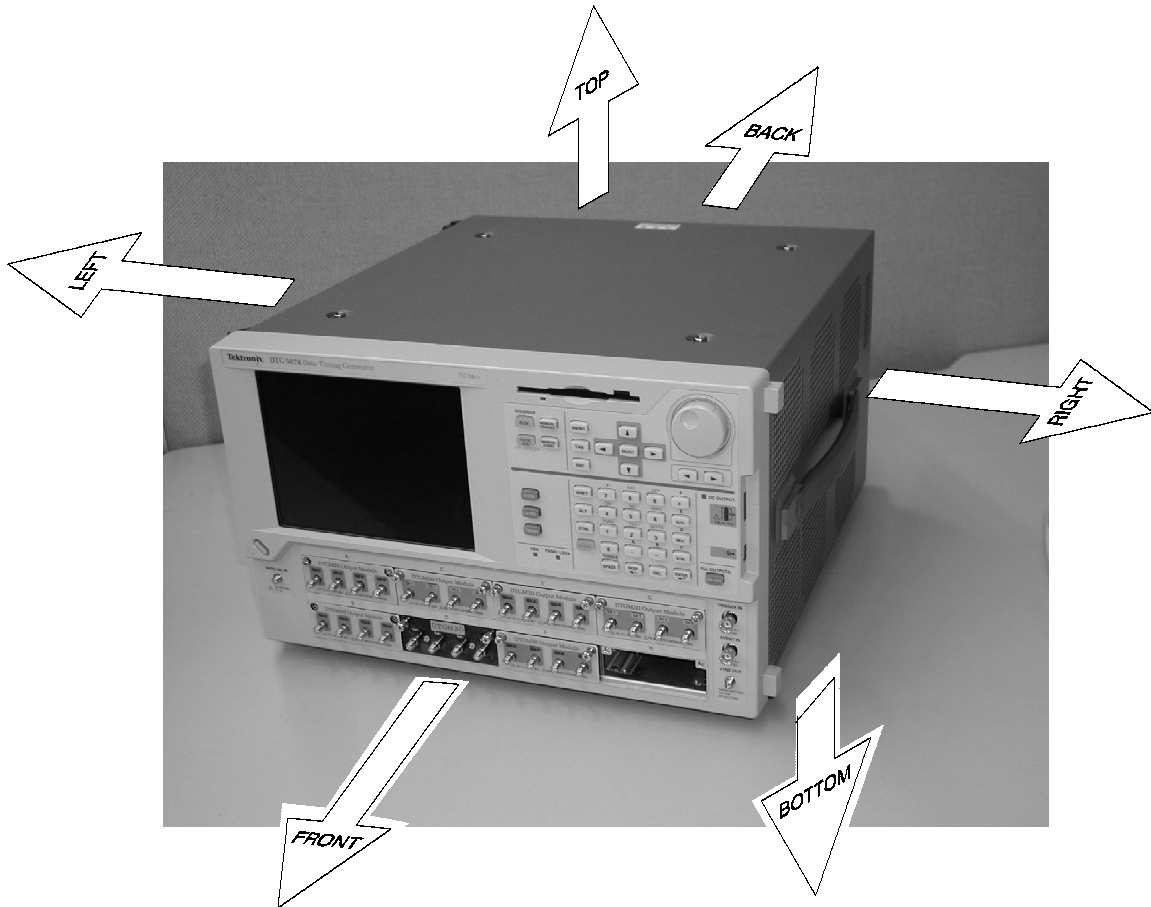

Figure 6-1: Instrument orientation (DTG5078)

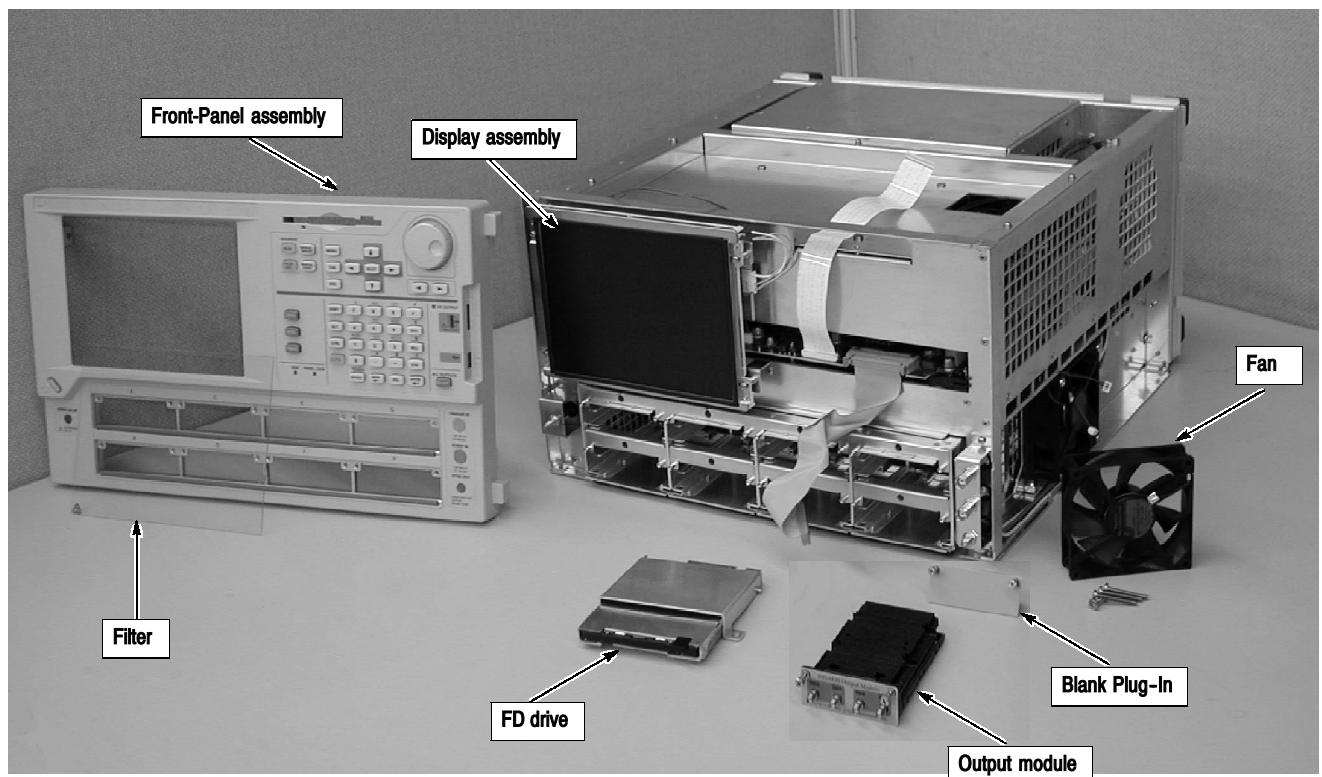
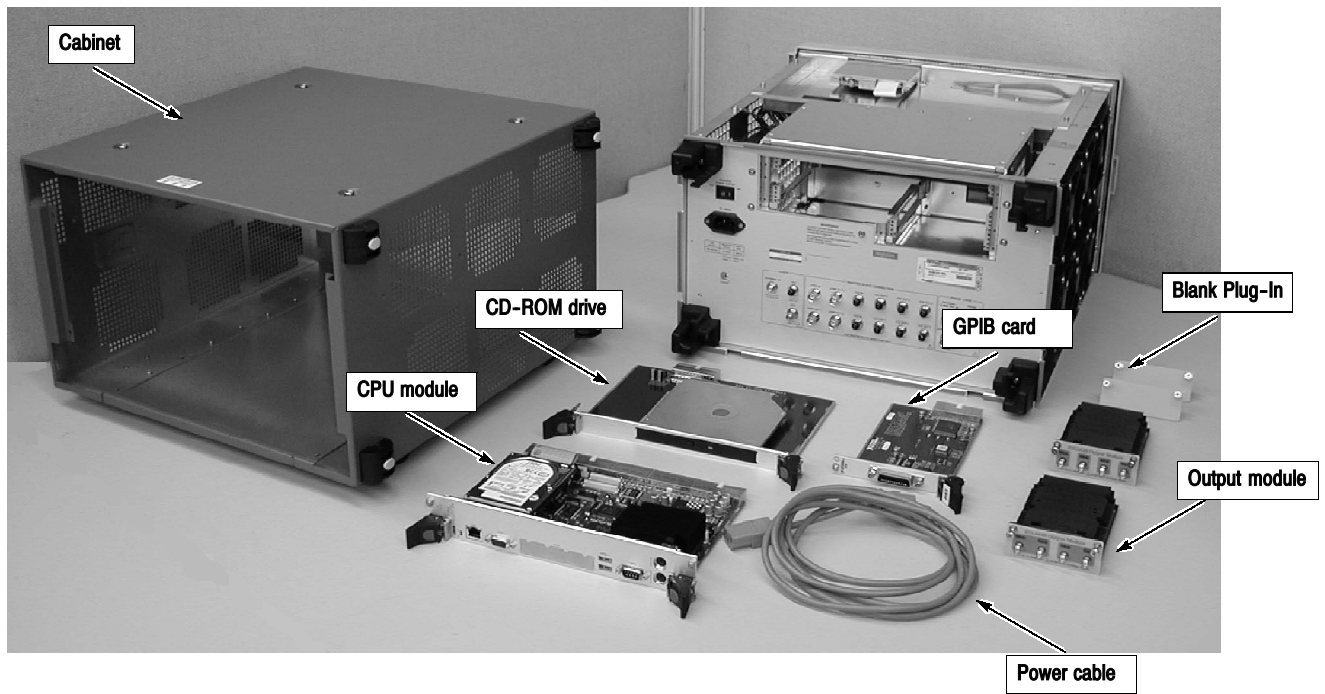

Figure 6-2: External modules

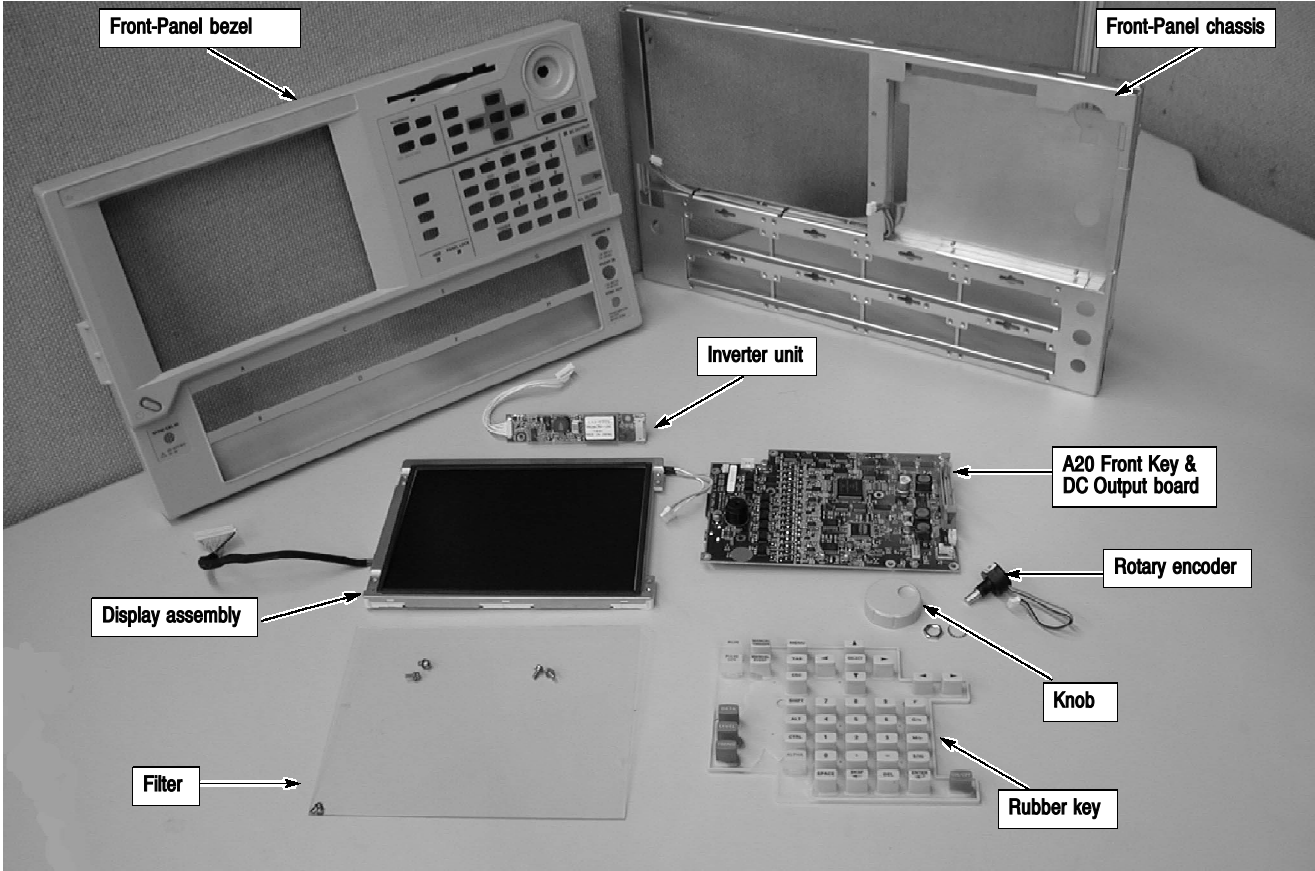

Figure 6-3: Front-Panel assembly & Display assembly

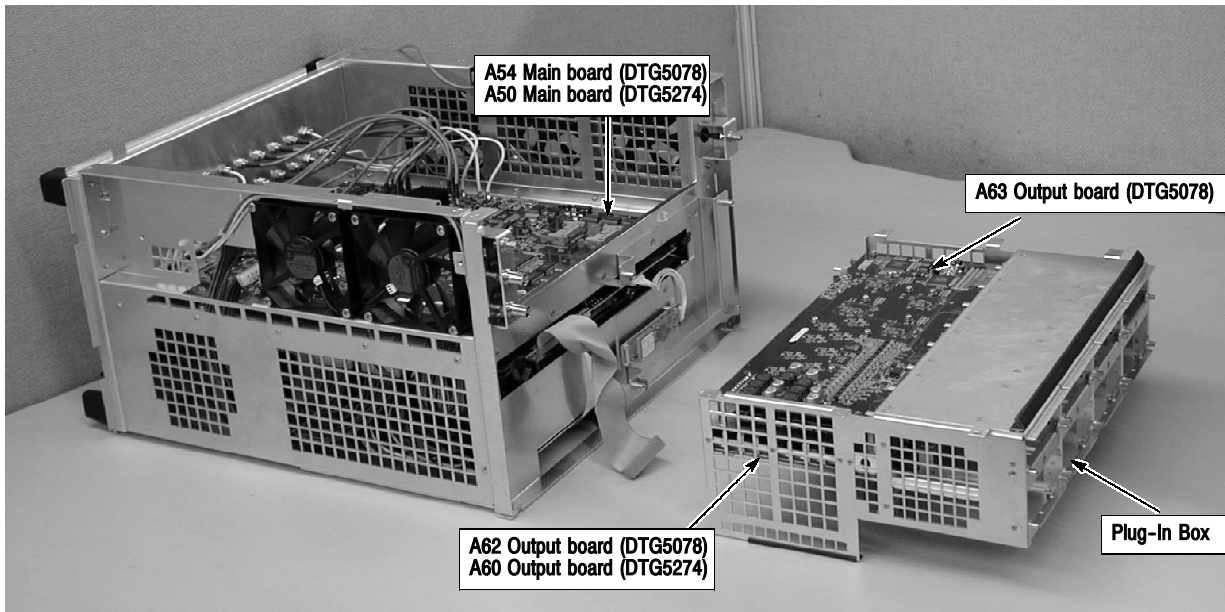

Figure 6-4: Internal modules (Lower)

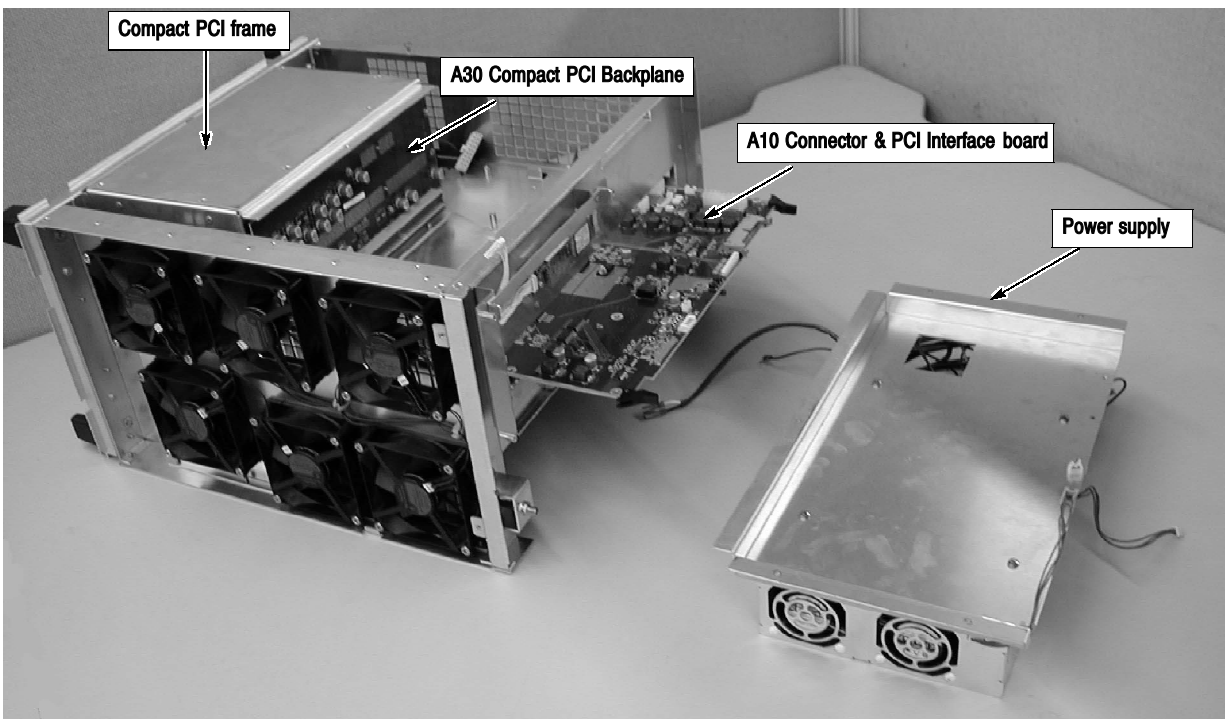

Figure 6-5: Internal modules (Upper)

Access Procedure

Begin with this procedure when you have identified a module to be removed for service.

1. If the data timing generator is running, push the front-panel On/Standby switch to shut it down. Then unplug the power cord from the rear panel AC power connector.
2. Find the module to be removed in Figures 6-2 through 6-5.

The title of the figure indicates whether the module is an external, internal module (lower), or internal module (upper) part.

3. If the module is externally mounted and no internal access is required, remove the module. Locate the necessary procedure in the *Procedures for External Modules* on page 6-16.
4. If the module is an internal-chassis module and access is required inside of the instrument, do the *Line Cord* procedure, and then do the *Cabinet* procedure. Both procedures are in the *Procedures for External Modules* subsection.
5. After completing those procedures, return to this procedure and continue with step 6.
6. If the module is an internal modules (Lower), access the reverse side of the chassis.
 - a. First do the procedure *Front-Panel assembly* as described in *Procedures for External Modules* (page 6-16).
 - b. Then do the removal procedure as described in *Procedures for Internal Modules (Lower)* on page 6-31.
7. If the module is an internal modules (Upper), access the inner-chassis.
 - a. First do the procedure *Front-Panel assembly* and *Display assembly* as described in *Procedures for External Modules* (page 6-16).
 - b. Then do the procedure as described in *Procedures for Internal Modules (Upper)*, page 6-38.
8. Re-install all modules previously removed. Read the instructions found at the end of the procedure that removes the module to be serviced. These instructions will guide you in re-installing all modules previously removed.

Procedures for External Modules

Complete the *Access Procedure* on page 6-15, before doing any procedure in this collection.

The following procedures are listed in order presented.

- Power cable
- Output Module and Blank Panel
- CPU module
- CD-ROM drive
- GPIB card
- Cabinet
- Feet & Rear-Panel
- FD drive
- Front-Panel assembly
- A20 Front Key & USB & DC Output board
- A22 Power Switch board
- Display Assembly
- Inverter
- Fan

Power cable

The data timing generator runs on a Windows 2000 operating system. Before unplug the power cable form the rear panel AC power connector, you need to confirm the data timing generator is not running.

1. If the data timing generator is running, push the front-panel On/Standby switch to shutdown.
2. Power off the PRINCIPAL POWER SWITCH on the rear panel and remove the power cord from the AC power connector on the rear panel.

Output Module and Blank Plug-In

You will need a screwdriver with a #2 Phillips tip (Items 1 and 3).

1. Orient the data timing generator so its bottom is down on the work surface and its front is facing you.
2. Loosen the two screws with screwdriver.
3. Grasp the right and left screws and slowly pull the Output module to remove it from the mainframe.

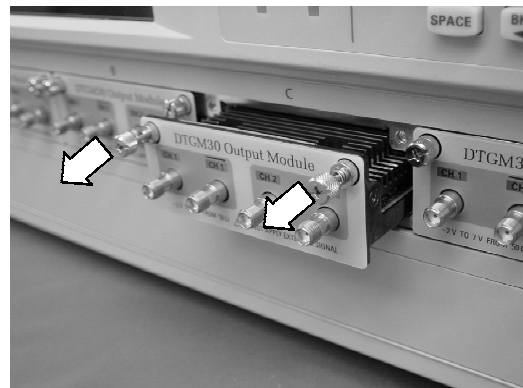
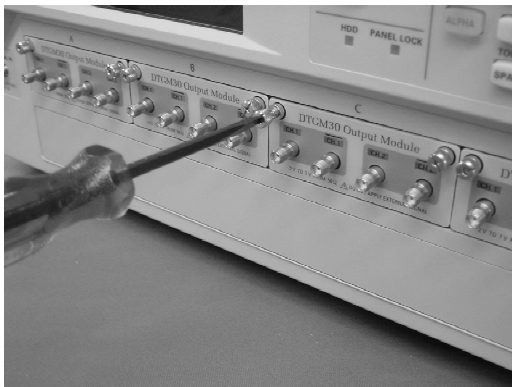

Figure 6-6: Output Module removal

Modules on the rear panel A CPU module, a CD-ROM drive, and a GPIB card are on the rear panel.

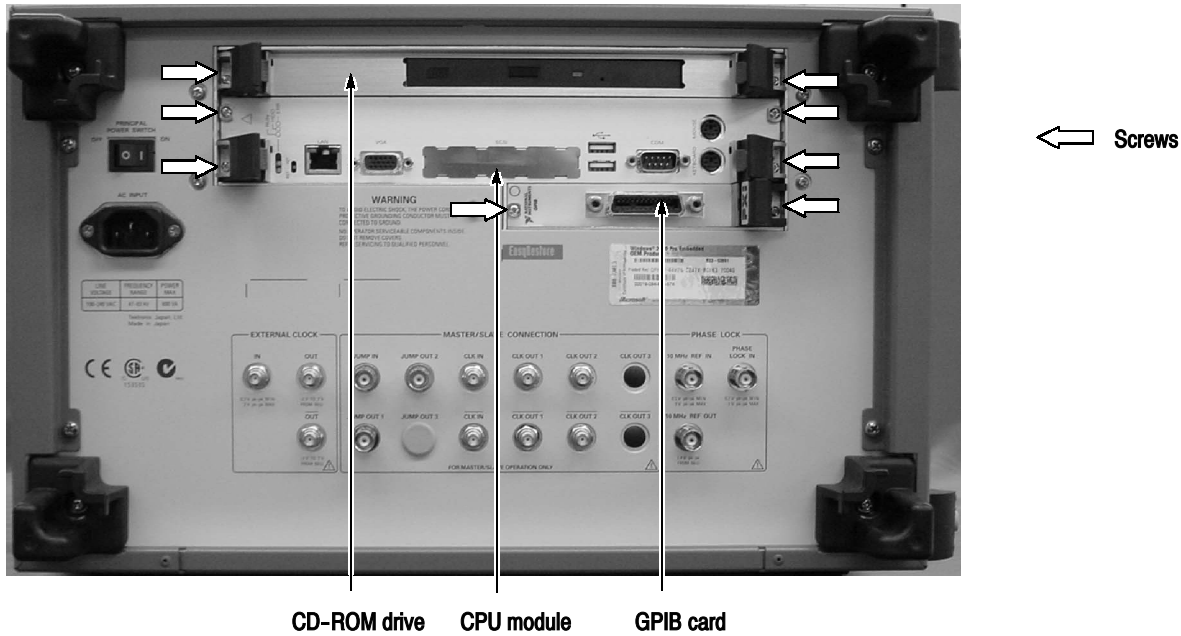

Figure 6-7: Modules on the rear panel

CD-ROM drive You will need a screwdriver with a #1 Phillips tip (Items 1 and 2).

1. Orient the data timing generator so its bottom is down on the work surface and its rear is facing you.
2. Loosen the two screws with screwdriver.



Figure 6-8: Loosen the screws

3. To remove the CD-ROM module, press the eject knobs by pushing the red release button to the outside.

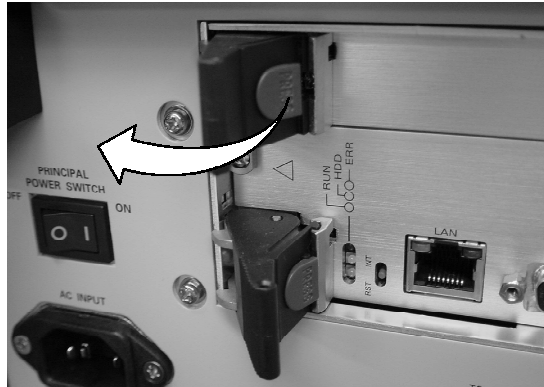

Figure 6-9: CD-ROM module removal

CPU module

You will need a screwdriver with a #1 Phillips tip (Items 1 and 2).

1. Orient the data timing generator so its bottom is down on the work surface and its rear is facing you.
2. Loosen the four screws with screwdriver.

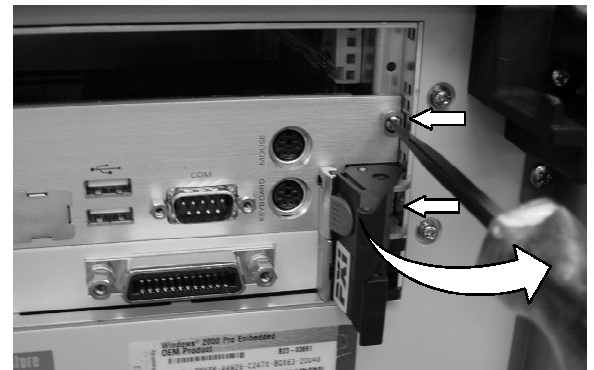
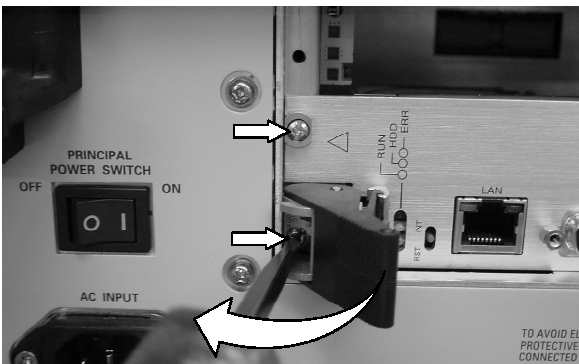

Figure 6-10: Loosen the screws

3. To remove the CPU module, press the eject knobs by pushing the red release button to the outside.
4. To install, do the procedure in reverse order.

GPIB card You will need a screwdriver with a #1 Phillips tip (Items 1 and 2).

1. Orient the data timing generator so its bottom is down on the work surface and its rear is facing you.
2. Loosen the two screws with screwdriver.

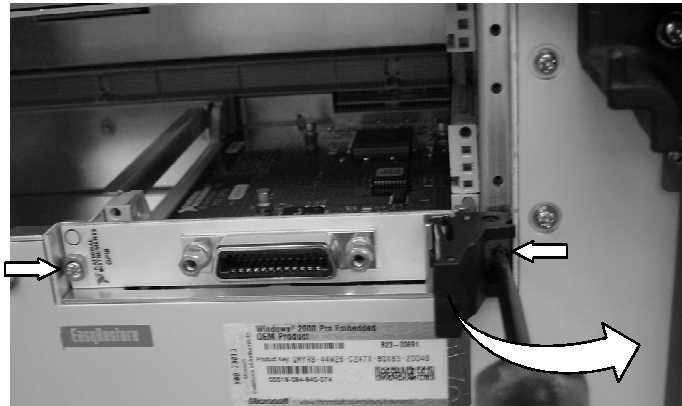

Figure 6-11: Loosen the screws

3. To remove the GPIB card, press the eject knob to the outside.
4. To install, do the procedure in reverse order.

Cabinet You will need a screwdriver with a Phillips #2 tip (Items 1 and 2). In order to remove the cabinet, it is necessary to remove seven screws.

1. Orient the data timing generator so that its Left side is down on the work surface.
2. Remove the three screws at the bottom of the cabinet.
3. Orient the data timing generator so its bottom is down on the work surface and its rear is facing you.
4. Remove the four screws at the rear of the cabinet. You need not to remove the screws attaching the feet.
5. Push the feet on the rear panel to slide out the main chassis.
6. When the main chassis comes out a little, grasp the front side of the main chassis then pull it out.
7. To install, do the procedure in reverse order.

NOTE. Take care not to bind or snag the cabinet on the internal cables when you remove it.

When removing or installing the cabinet, take care not to damage the EMI gaskets on the cabinet, or the data timing generator may not meet its emissions requirements (EMI).

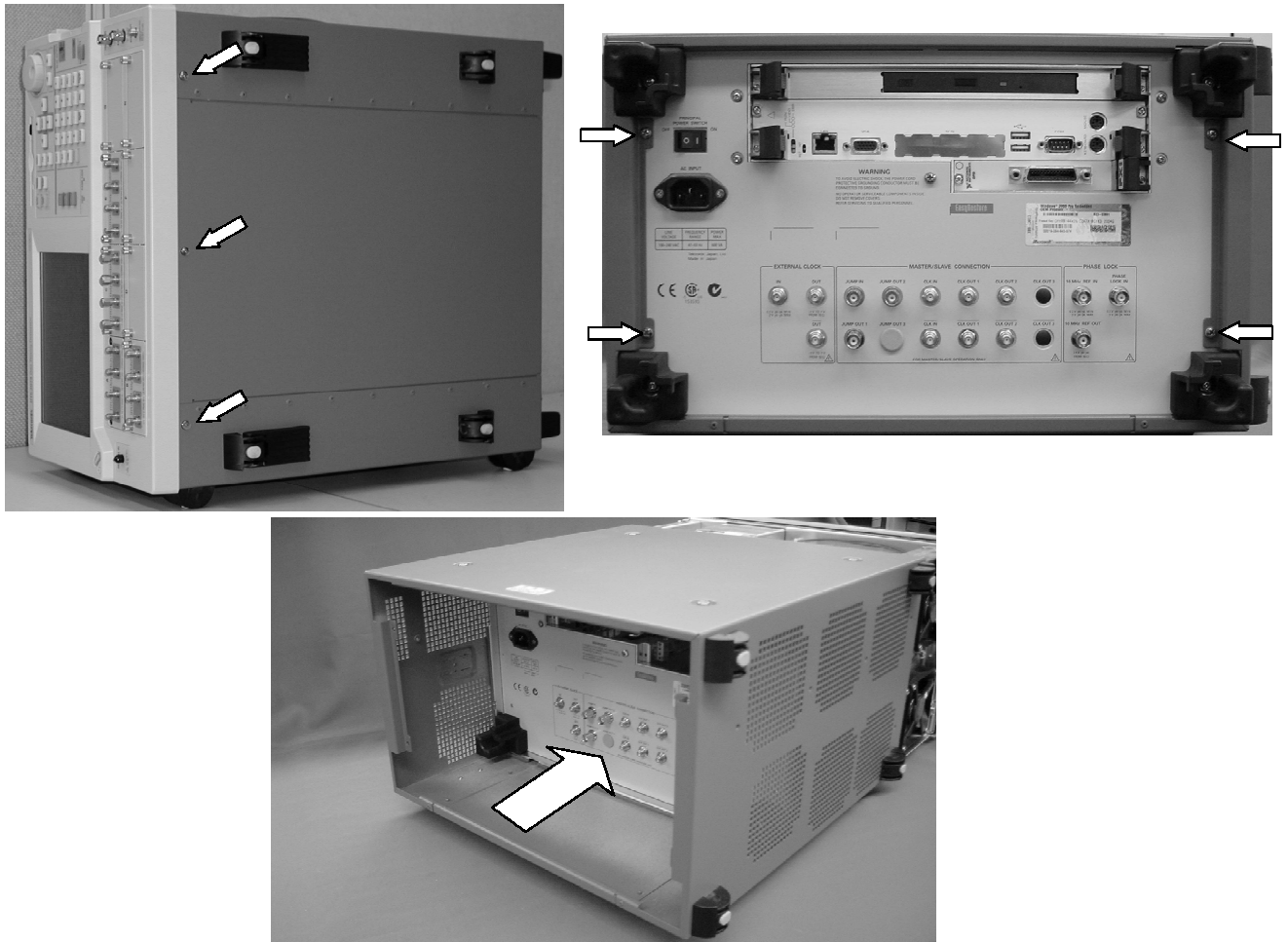

Figure 6-12: Cabinet removal

Feet and Rear-Panel

You will need a screwdriver with a Phillips #2 tip (Items 1 and 3).

1. Orient the data timing generator so its bottom is down on the work surface and its rear is facing you.
2. Remove the four screws at the feet and one screw on the rear panel.

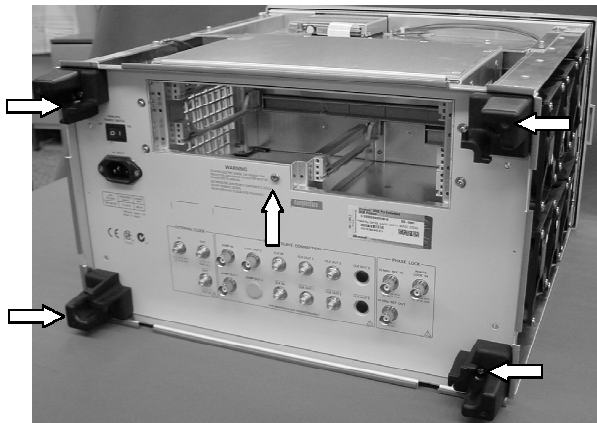

Figure 6-13: Remove the screws

3. To install, do the procedure in reverse order.

Front-Panel Assembly

You will need a screwdriver with a Phillips #2 tip (Items 1 and 3).

1. Orient the data timing generator so its bottom is down on the work surface and its front is facing you.
2. Remove the four screws mounting the front-panel assembly to the main chassis.

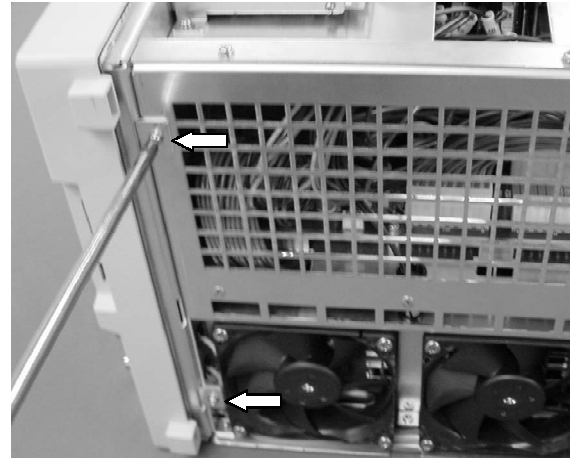

Figure 6-14: Front-Panel assembly removal

3. Grasp the front-panel trim ring, pull the front-panel assembly toward you taking care not to damage the flat cable connected the A10 board in a main frame with the front-panel module.

NOTE. When removing or installing the cabinet, take care not to damage the EMI gaskets on the cabine, or the data timing generator may not meet its emissions requirements (EMI).

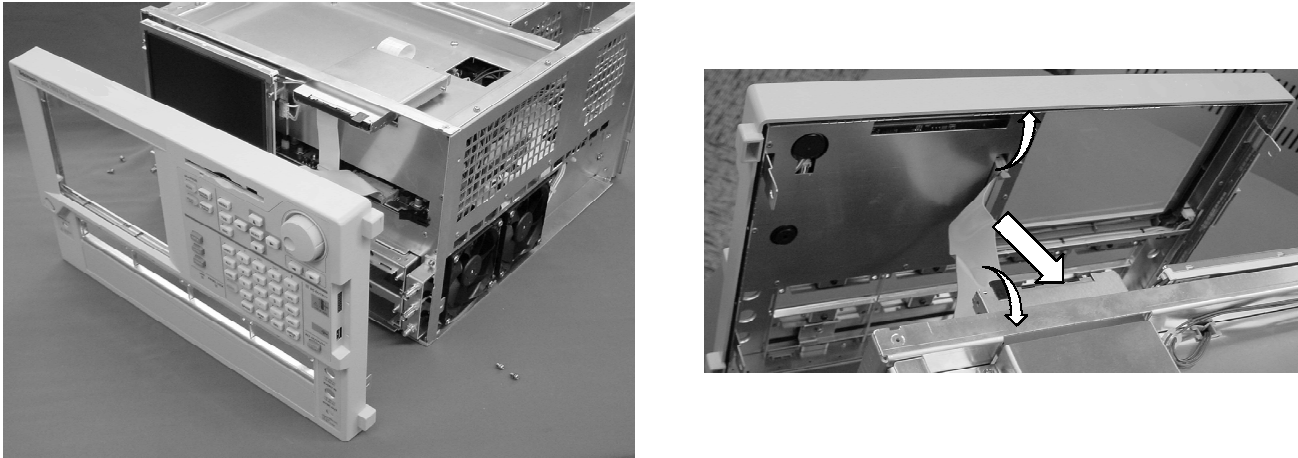

Figure 6-15: Front-Panel assembly removal

4. Unplug the flat cable connected to the A10 board in a main frame.
5. To install, do the procedure in reverse order.

FD drive

You will need a screwdriver with a Phillips #2 tip (Items 1 and 3).

1. Orient the data timing generator so its bottom is down on the work surface and its front is facing you.
2. Disconnect the ribbon cable.
3. Remove the two screws, slide the FD drive toward the rear panel and pull it up.

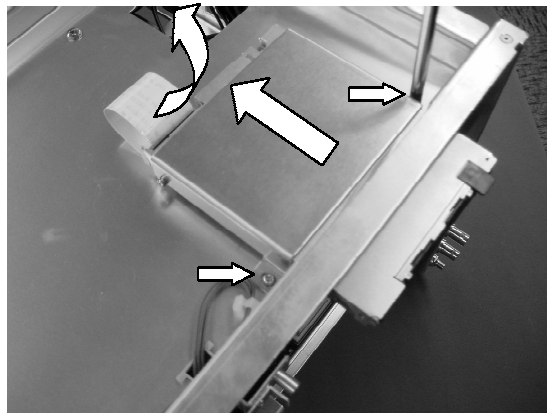

Figure 6-16: FD drive removal

4. To install, do the procedure in reverse order.

Front-Panel Chassis

This procedure is required before removal and installation for the front-panel and front-panel buttons.

You will need a screwdriver with a #1 and #2 Phillips tip (Items 1, 2 and 3).

1. Remove the Front-Panel assembly immediately preceding this procedure.
2. Pull out the Knob from the front-panel by hand.
3. Orient the face of front-panel is down on the work surface.
4. Remove the filter from the front-panel frame.
5. Remove the front panel chassis from the bezel doing the following steps.

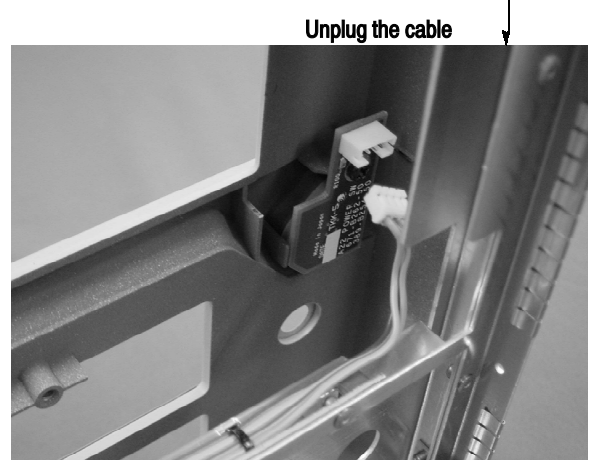
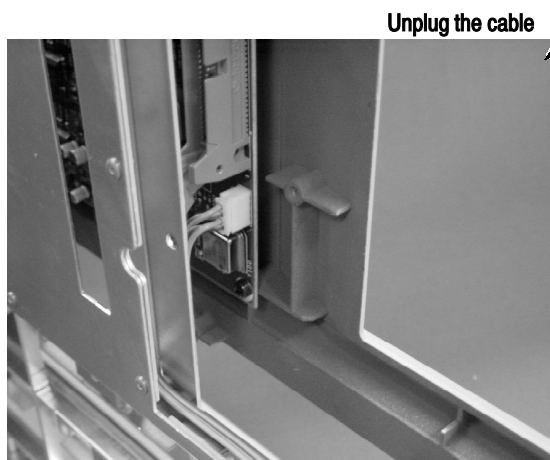
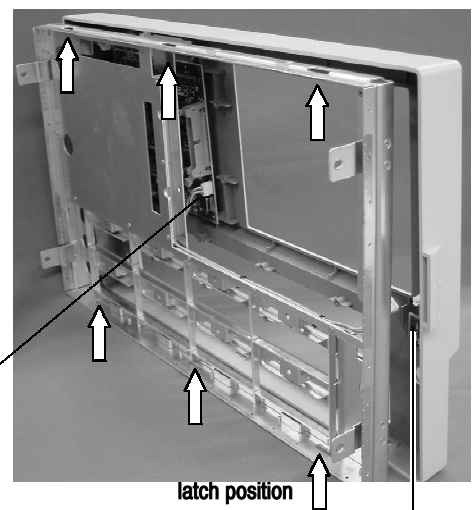
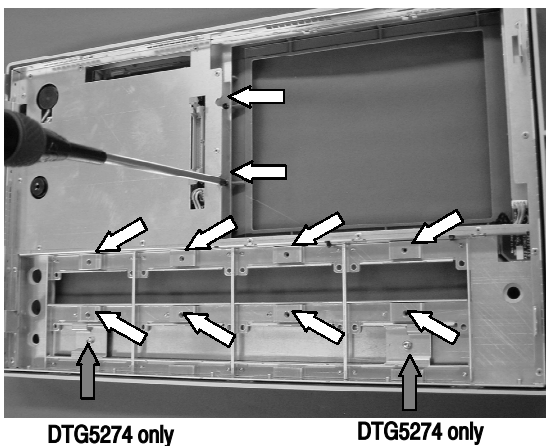

Figure 6-17: Front-panel chassis removal

- a. Remove the ten tapping screws using the #1 Phillips screw driver.
 - b. (DTG 5274 only): Remove the two screws with the washer at the bottom side using the #2 Phillips screw driver.
 - c. (DTG 5274 only): Remove the bottom blank panel and the retaining panel.
 - d. Remove the front-panel bezel by releasing the latches a little. There are three of them on the top and bottom.
 - e. Unplug the two connectors from the A20 and A22 board on the front-panel bezel.
6. To install, do the procedure in reverse order.

A20 Front Key & DC Output Board

This procedure includes removal and installation instructions for the front-panel and front-panel buttons.

You will need a screwdriver with a #1 Phillips tip (Items 1 and 2).

1. Remove the Front-Panel Chassis.
2. Unplug the rotary encoder cable connector J400 on the A20 Front Key & DC Output board.

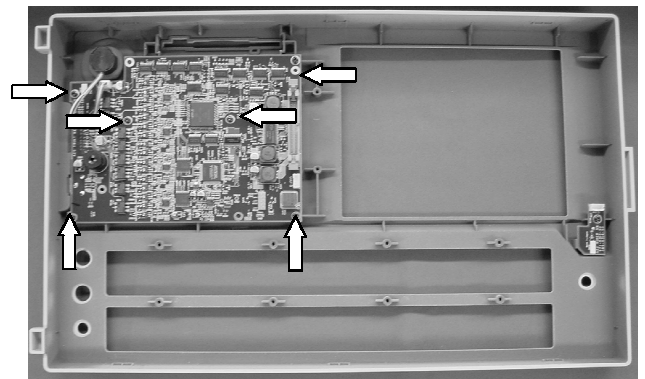
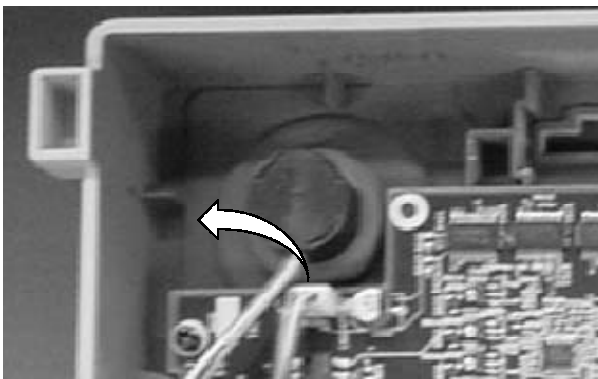

Figure 6-18: A20 Front Key & DC Output board removal

3. Remove the six tapping screws using the #1 Phillips screw driver.
4. Lift the A20 Front key & DC Output board.
5. To remove the rubber key, push the button from the front-panel surface.
6. To remove the Rotary encoder, pull out the Rotary encoder knob from the front-panel by hand, and remove a hexagon nut.

7. To install, do the procedure in reverse order.

A22 Power Switch Board

This procedure includes removal and installation instructions for the front-panel and front-panel chassis.

You will need a screwdriver with a #2 Phillips tip (Items 1 and 2).

1. Remove the Front-Panel Chassis.
2. Remove a tapping screw attaching the A22 board to the front-panel using the #1 Phillips screw driver.

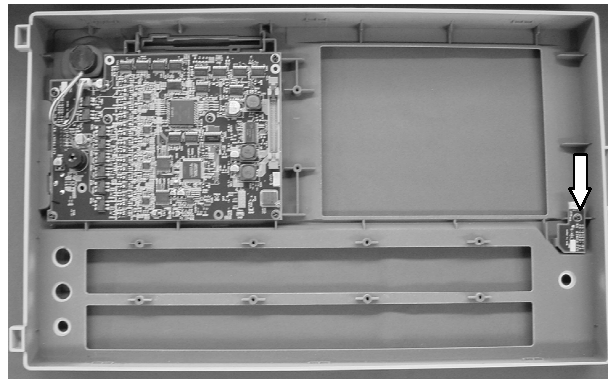

Figure 6-19: A22 Power Switch Board removal

3. To install, do the procedure in reverse order.

Display Assembly

You will need a screwdriver with a #2 Phillips tip (Items 1 and 3).

1. Remove the Front-Panel assembly.
2. Orient the data timing generator so its bottom is down on the work surface and its front is facing you.
3. Unplug the cable connected to the Back Light board.
4. Remove the four screws on top and bottom of the display frame of the LCD that mount the display assembly to the chassis.
5. Unplug the cable connected to the A10 Connector & PCI Interface board.

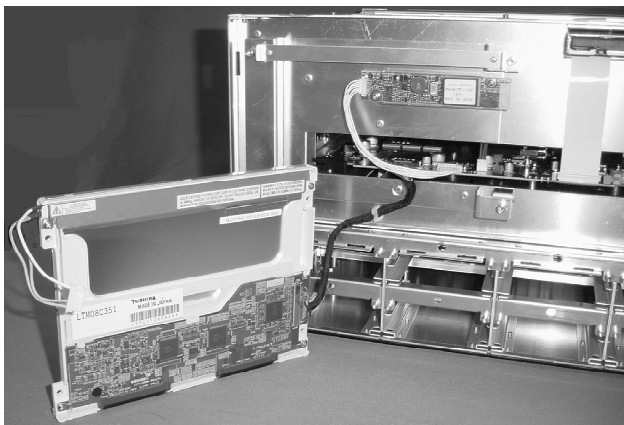
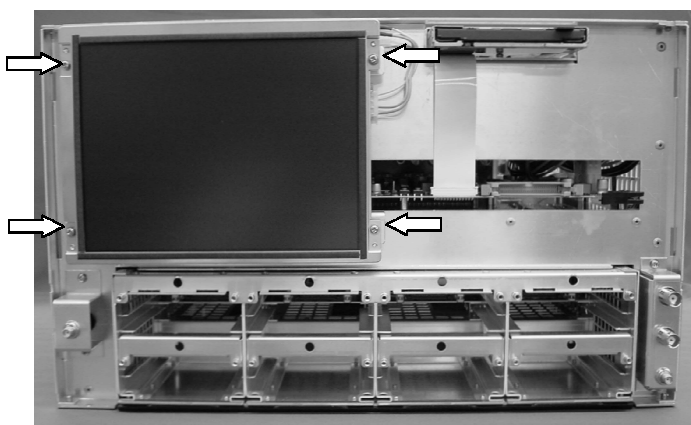

Figure 6-20: Display assembly removal

6. To install, do the procedure in reverse order.

Inverter unit You will need a screwdriver with a #2 Phillips tip (Items 1 and 3).

1. Remove the Display assembly.
2. Unplug the cable connected to J540 on the A10 Connector & PCI Interface board.
3. Remove the two screws.

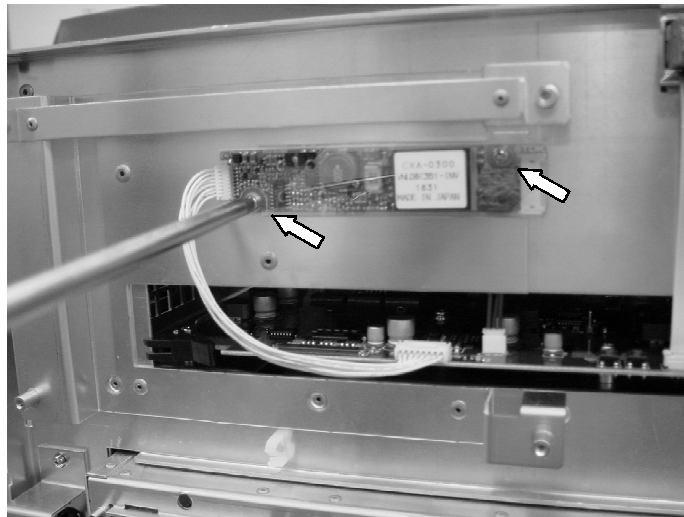

Figure 6-21: Inverter board removal

4. To install, do the procedure in reverse order.

Fan You will need a screwdriver with a #2 Phillips tip (Items 1 and 3).

1. Locate the fan. The data timing generator has 6 fans on the left side and 2 fans on the right side.
2. Orient the data timing generator so its bottom is down on the work surface and its front is facing you.
3. Slide the cable connector at the fan to unplug the cable.
4. Remove the four screws attaching the fan to the main frame, and lift the fan away.

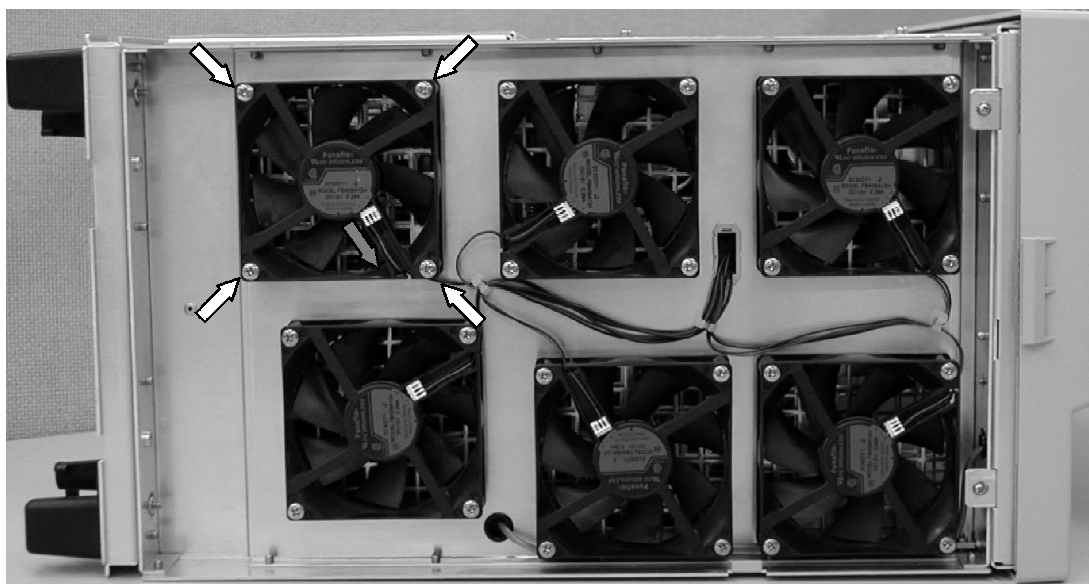

Figure 6-22: Fan removal

5. To install, do the procedure in reverse order.

Procedures for Internal Modules (Lower)

You should have completed the *Access Procedure* before doing any procedure in this collection. This section describes removal/installation procedures for the following modules:

- Plug In Box
- A60 (DTG5274) / A62(DTG5078) / A63(DTG5078) Output Board
- A50 (DTG5274) / A54 (DTG5078) Main Board

Plug-In Box You will need a screwdriver with a #2 Phillips tip (Items 1 and 3).

1. Remove the Front-Panel assembly.
2. Orient the data timing generator so its top is down on the work surface and its rear is facing you.
3. Remove the four screws attaching the support bracket and the Plug-In Box to the chassis.

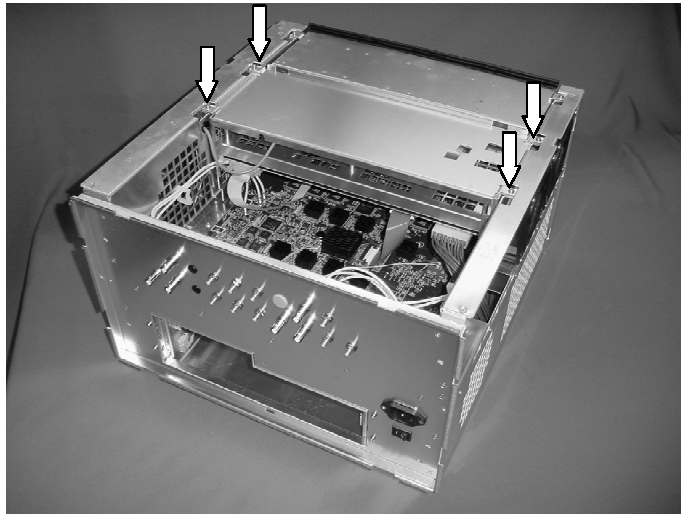

Figure 6-23: Support bracket removal

4. Unplug the following cables and connectors:
 - DTG5078
 - The coaxial cable to SKEW CAL IN connector at J300
 - a. Grasp the cable root firmly and pull it. To avoid damaging the SMB cable, do not pull hard on the cable.
 - Two flat cables to A54 Main board
 - b. Push the connector latch levers open to both side.
 - Four flex cables to A54 Main board
 - c. Pull the flex cable by pushing the upper button of the part of the connector.
 - Two power cables to A10 Connector board
 - d. Push the latch lever to release, then unplug the connector.

■ DTG5274

- The coaxial cable to SKEW CAL IN connector at J300

e. Grasp the cable root firmly and pull it. To avoid damaging the SMB cable, do not pull hard on the cable

- One flat cable to A54 Main board

f. Push the connector latch levers open to both side.

- One flex cable to A54 Main board

g. Pull the flex cable by pushing the upper button of the part of the connector.

- One power cable to A10 Connector board

h. Push the latch lever to release, then unplug the connector.

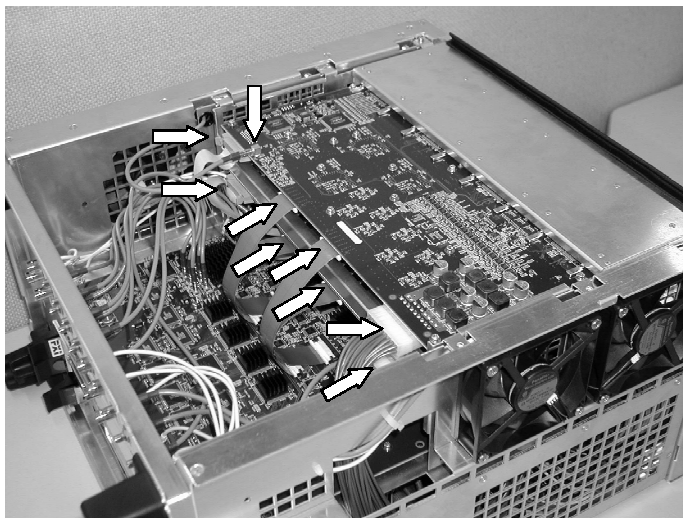

DTG5078

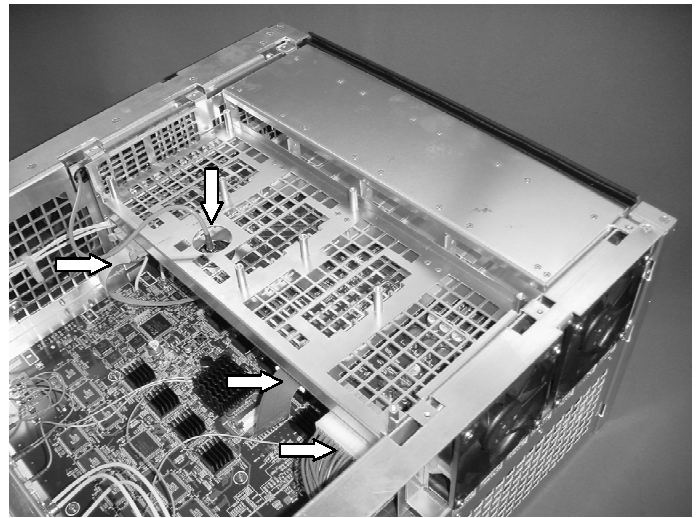

DTG5274

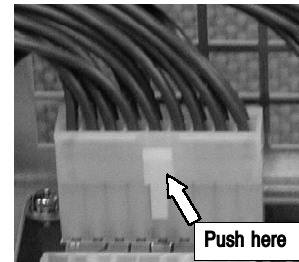
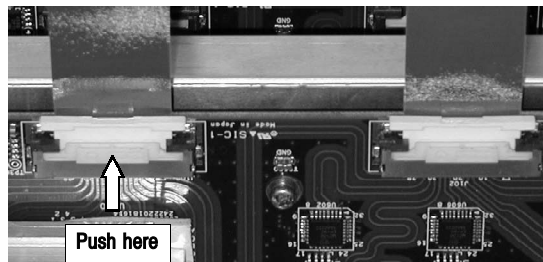
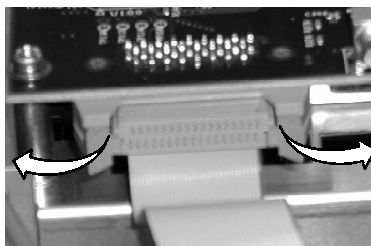
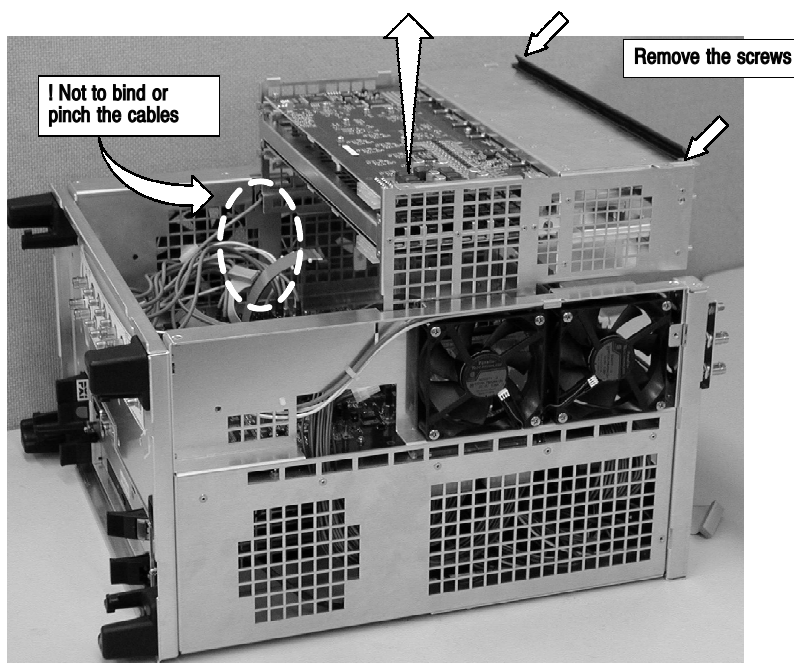

Figure 6-24: Unplug the cables and connectors

5. Remove the two screws attaching the Plug-In Box to the chassis.
6. Remove the Plug-In Box:
 - a. Tilt up the Plug-In Frame back a little, then slide it toward the rear panel.
 - b. Lift the Plug-In Box up away from the chassis.

NOTE. When removing and installing the Plug-In Box, be careful not to catch the cables.



7. To install, do the procedure in reverse order.

A60 / A62 / A63 Output board

The DTG5078 has A62 and A63 Output board and the DTG5274 has A60 Output board. Each Output board is built in the Plug-In Box.

You will need a screwdriver with a #2 Phillips tip (Items 1 and 3).

1. Remove the Plug-In Box.
2. Remove the nine screws attaching the Output board to the Plug-In Box.

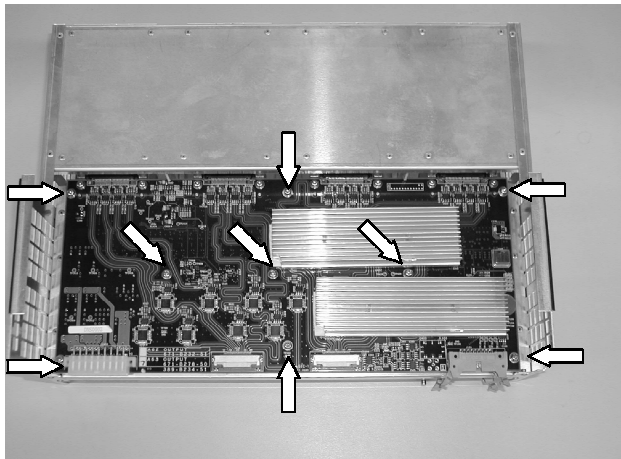

A62 Output board (DTG5078)

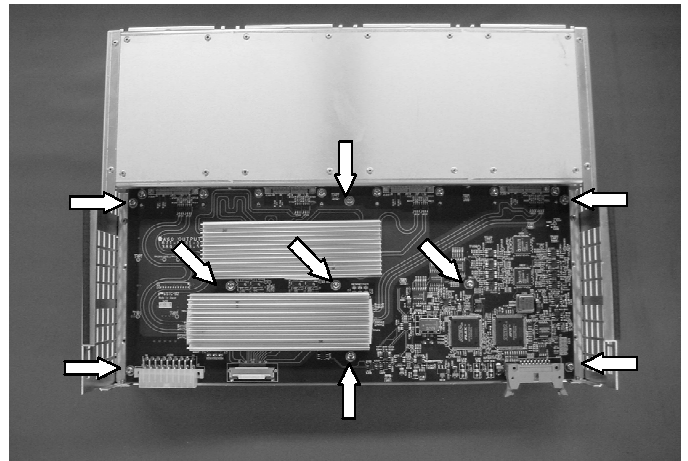

A60 Output board (DTG5274)

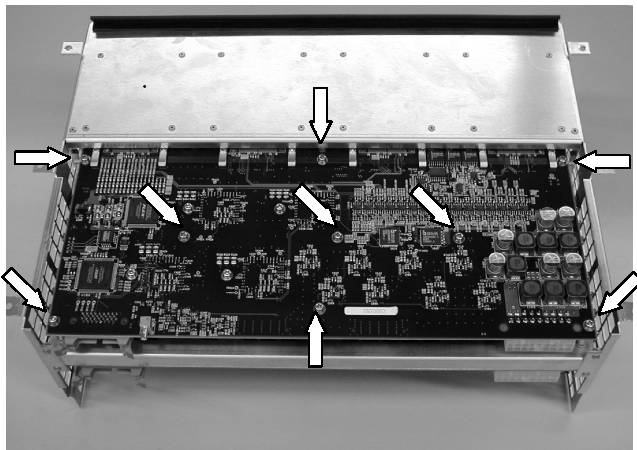

A63 Output board (DTG5078)

Figure 6-25: Unplug the cables and connectors

3. To install, do the procedure in reverse order.

A50 / A54 Main board The DTG5078 has A54 Main board and the DTG5274 has A50 Main board.

You will need a screwdriver with a #2 Phillips tip (Items 1 and 3).

1. Remove the Plug-In Box.
2. Orient the data timing generator so its top is down on the work surface.
3. Unplug the following cables and connectors:
 - DTG5078
 - 18 coaxial cables to rear panel connectors
 - Two flat cables to A62/A63 Output board
 - a. Push the connector latch levers open to both side.
 - Four flex cables to A62/A63 Output board
 - b. Pull the flex cable by pushing the upper button of the part of the connector.
 - One power cable to A10 Connector board
 - c. Push the latch lever to release, then unplug the connector.
 - DTG5274
 - 15 coaxial cables to rear panel connectors
 - One flat cable to A60Output board
 - d. Push the connector latch levers open to both side.
 - One flex cable to A60 Output board
 - e. Pull the flex cable by pushing the upper button of the part of the connector.
 - One power cable to A10 Connector board
 - f. Push the latch lever to release, then unplug the connector.

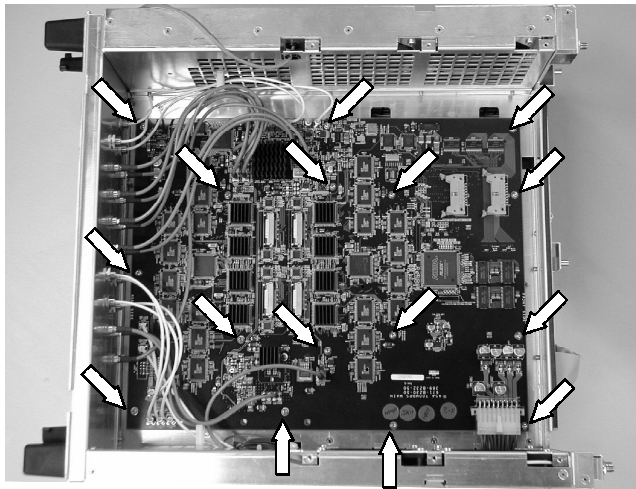

A54 Main board (DTG5078)

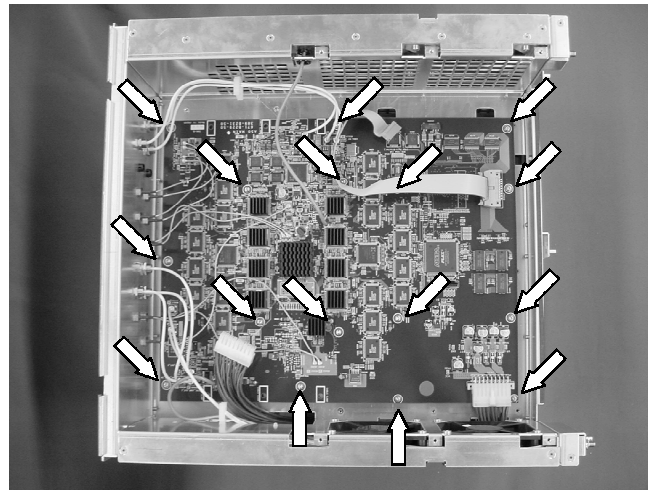

A50 Main board (DTG5274)

Figure 6-26: Unplug the cables and connectors

4. Remove the 16 screws attaching the A50/A54 Main board to the main chassis.



CAUTION. A50/A54 Main board has a connector (J100) on the back side of the Main board on the front-panel side, and is connected with A10 Connector & PCI Interface board by this connector. When you remove the A50/A54 Main board, raise the board perpendicularly and carefully unplug each connector.

5. Carefully lift the A50/A54 Main board a little to unplug the connector on the back.
6. After unplugging the A10 Connector & PCI Interface board, lift the A50/A54 Main board from the chassis to complete the removal.
7. To install, do the procedure in reverse order.

NOTE. When you have exchanged A50/A54 Main board, you need to enter the serial number. Refer to Service Password section on page 6-73.

Procedures for Internal Modules (Upper)

You should have completed the *Access Procedure* before doing any procedure in this collection. This section describes removal/installation procedures for the following modules:

- A10 Connector Board
- A30 Compact PCI Back Plane
- Compact PCI Frame

Power Supply

You will need a screwdriver with a #2 Phillips tip (Items 1 and 3).

1. Remove the FD drive.
2. Orient the data timing generator so its bottom is down on the work surface and its front is facing you.
3. Release the three cables on the surface of the power supply from the cable holder, and free from the power supply chassis.
4. Remove the cables to chassis ground and AC connector.
5. Remove the six screws and lift up the power supply.

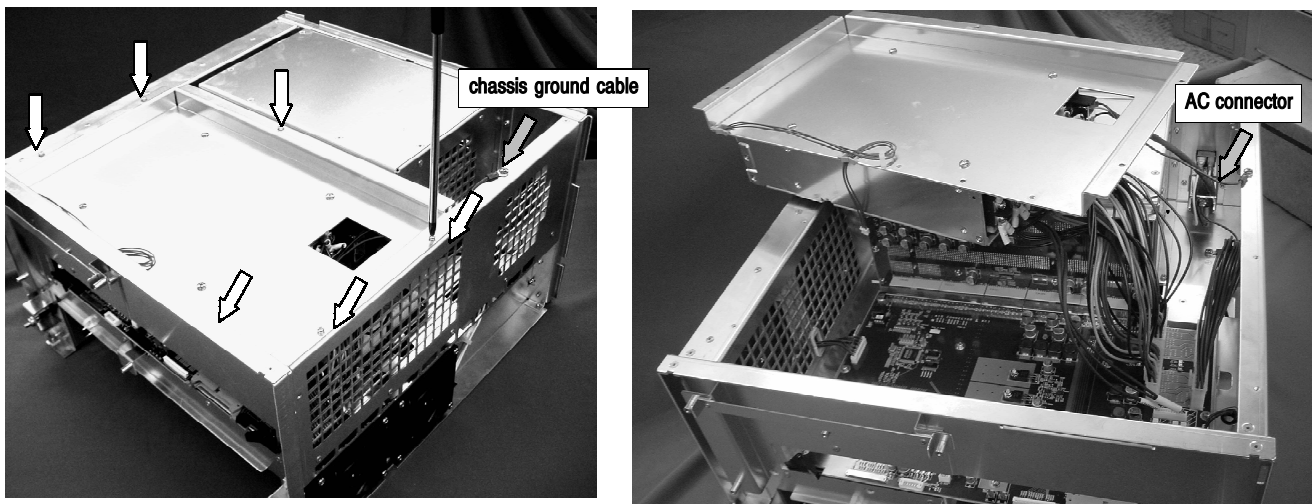

Figure 6-27: Power supply removal

6. To remove the power supply, lift up the module a little out of the main chassis and unplug the four cable connectors to the A10 Connector board .
7. Lift the module up out of the main chassis to complete removal.
8. To install, do this procedure in reverse order.

A10 Connector Board

You will need a screwdriver with a #2 Phillips tip (Items 1 and 3).

1. Remove the Front-Panel Assembly, Display Assembly, Power Supply, and A50/A54 Main board immediately preceding this procedure.
2. Orient the data timing generator so its bottom is down on the work surface .
3. Unplug the following cables and connectors:
 - Two fan power cables
 - The flex cable to the FD drive
 - The flat cable to the A20 Front Key & DC Output board
 - The cable to the Inverter board
 - The power cables to the A54 Main board, A62 and A63 Output boards (DTG5078), to the A50 Main board, A60 Output board (DTG5204)
4. Remove the ten screws attaching the A10 Connector & PCI Interface board to the main chassis.

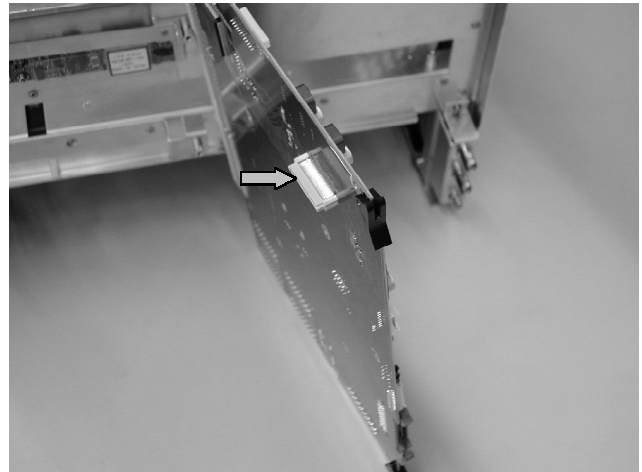
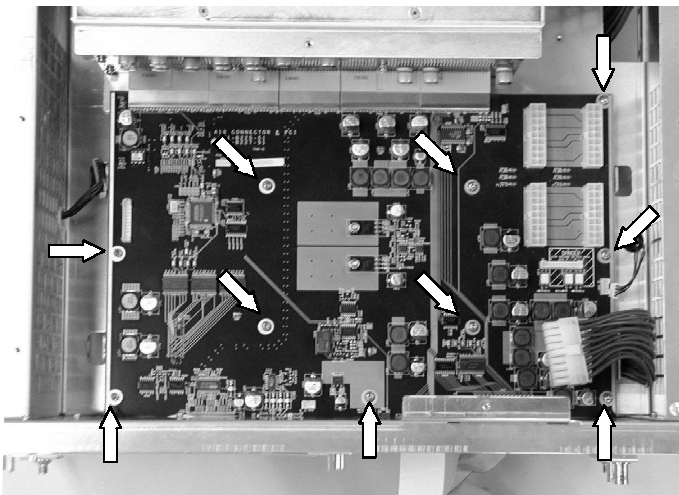

Figure 6-28: A10 Connector & PCI Interface board removal



CAUTION. *The A10 Connector & PCI Interface board has a connector (J410) in a frontpanel-hand side on its back surface, and is connected with A50/A54 Main board (See Figure 6-28) .*

When you remove the A10 Connector & PCI Interface board, remove the A50/A54 Main board at first. (Or raise the board perpendicularly and carefully to unplug each connectors.)

5. To remove the A10 Connector & PCI Interface board, press the eject knobs toward the outside, then pull out the board.

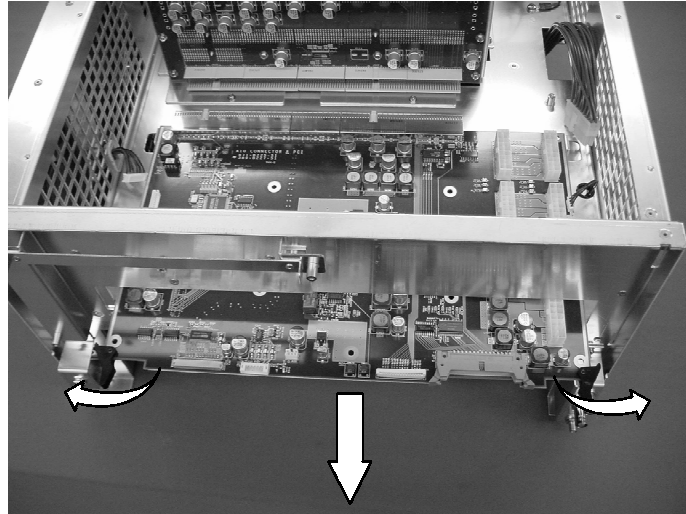

Figure 6-29: A10 Connector & PCI Interface board removal

6. To install, do the procedure in reverse order.

Compact PCI Frame

You will need a screwdriver with a #2 Phillips tip (Items 1 and 3).

1. Remove the CPU unit, CD-ROM drive, GPIB card, Front-Panel Assembly, Display Assembly, Power Supply, A50/A54 Main board and A10 Connector & PCI Interface board immediately preceding this procedure.
2. Orient the data timing generator so its bottom is down on the work surface .
3. Remove the four screws on the bottom and the four screws on the rear panel.
4. Lift the Compact PCI Frame up away from the main chassis.

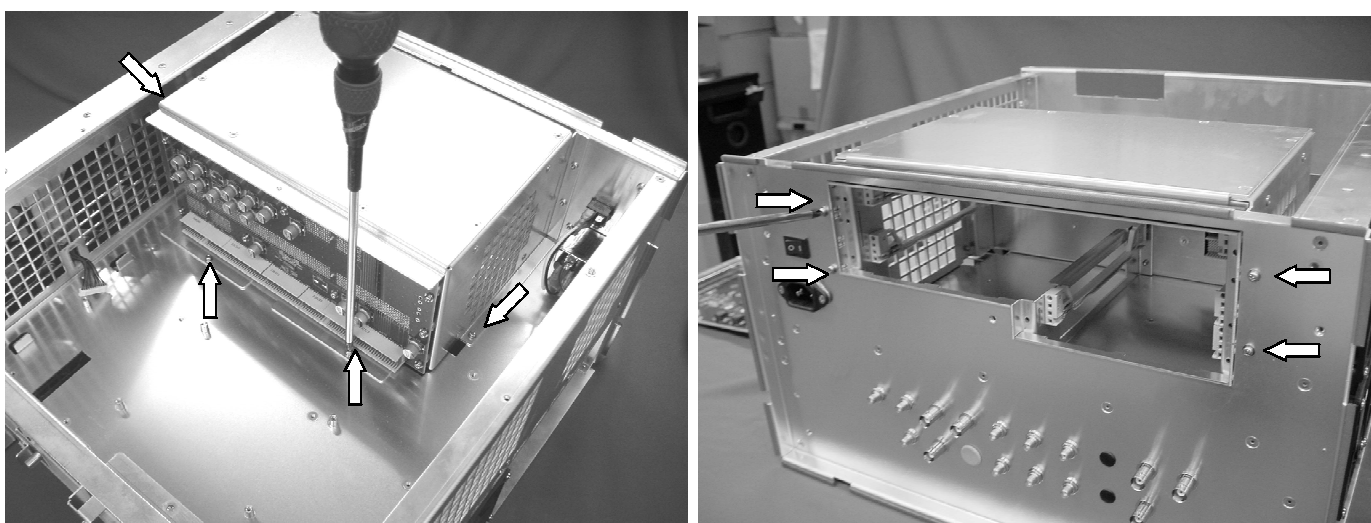

Figure 6-30: Compact PCI Frame removal

5. To install, do the procedure in reverse order.

A30 Compact PCI Backplane

You will need a screwdriver with a #2 Phillips tip (Items 1 and 3).

1. Remove the Compact PCI Frame immediately preceding this procedure.
2. Orient the Compact PCI Frame so its rear is down on the work surface .
3. Remove the nine screws attaching the A30 Compact PCI Backplane board to the Compact PCI Frame.

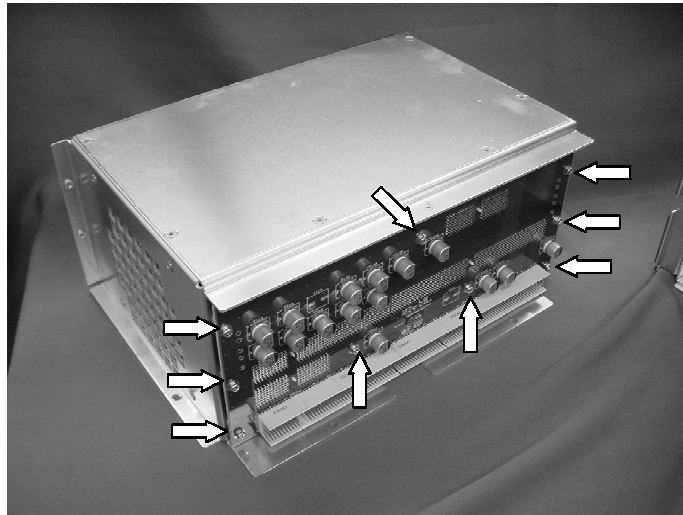

Figure 6-31: A30 Compact PCI Backplane removal

4. To install, do the procedure in reverse order.

Troubleshooting

This section contains information to help you to isolate faulty modules in the data timing generator.

- Troubleshooting trees
- Diagnostics

Troubleshooting trees show how to find and isolate faulty modules. The Diagnostics section describes the diagnostics supplied with the data generator, its operation and status messages.

After troubleshooting and identifying the faulty part, follow the *Removal and Installation Procedures* section to exchange the modules.

Troubleshooting tree

This subsection consists of the following flowcharts:

- Figure 6-32 to 6-34: Primary Troubleshooting Procedure
- Figure 6-36: Troubleshooting Procedure A - Power Supply and A10 board section
- Figure 6-35: Troubleshooting Procedure B - Display section.

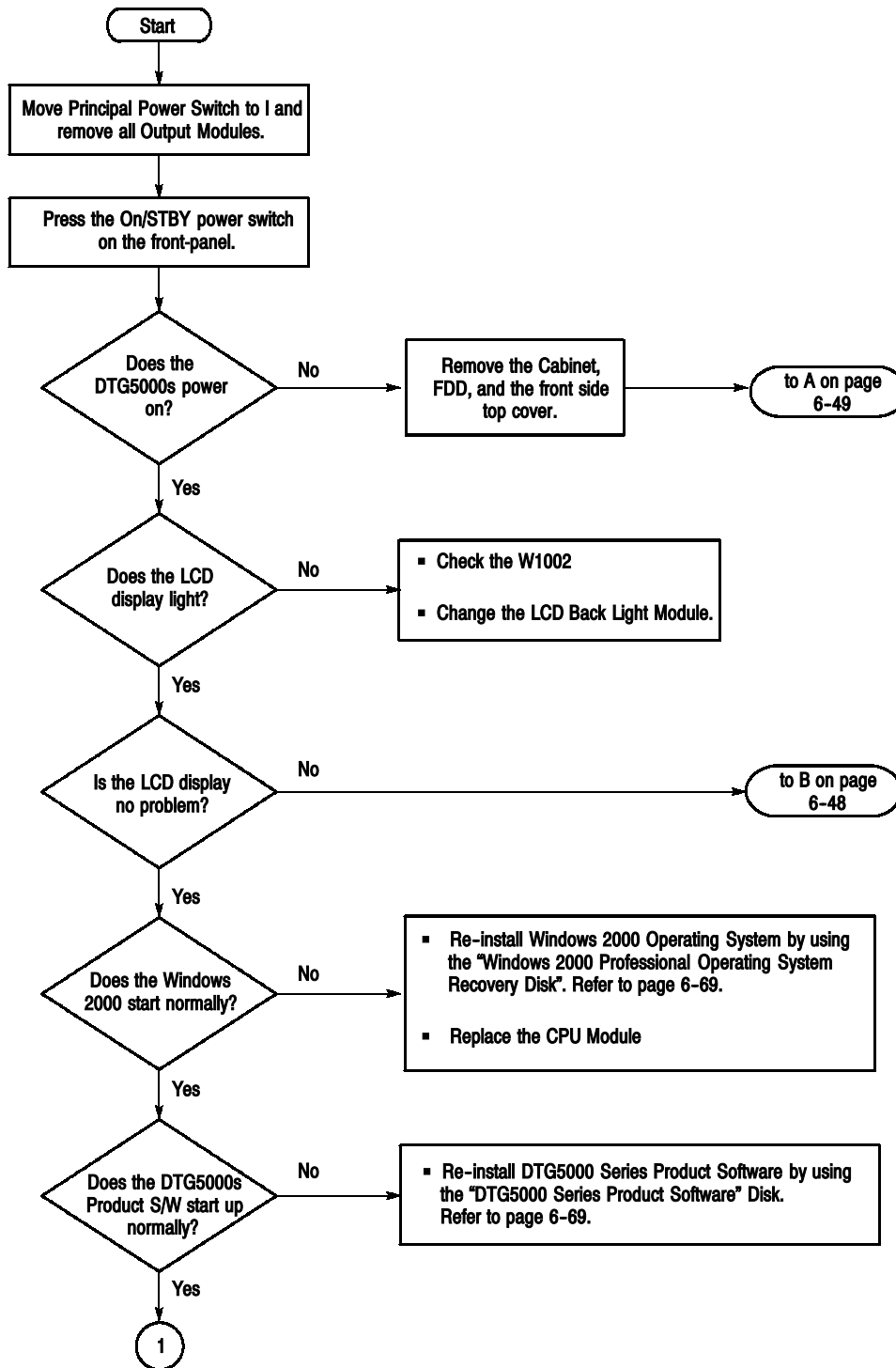

Figure 6-32: Primary troubleshooting procedure (1)

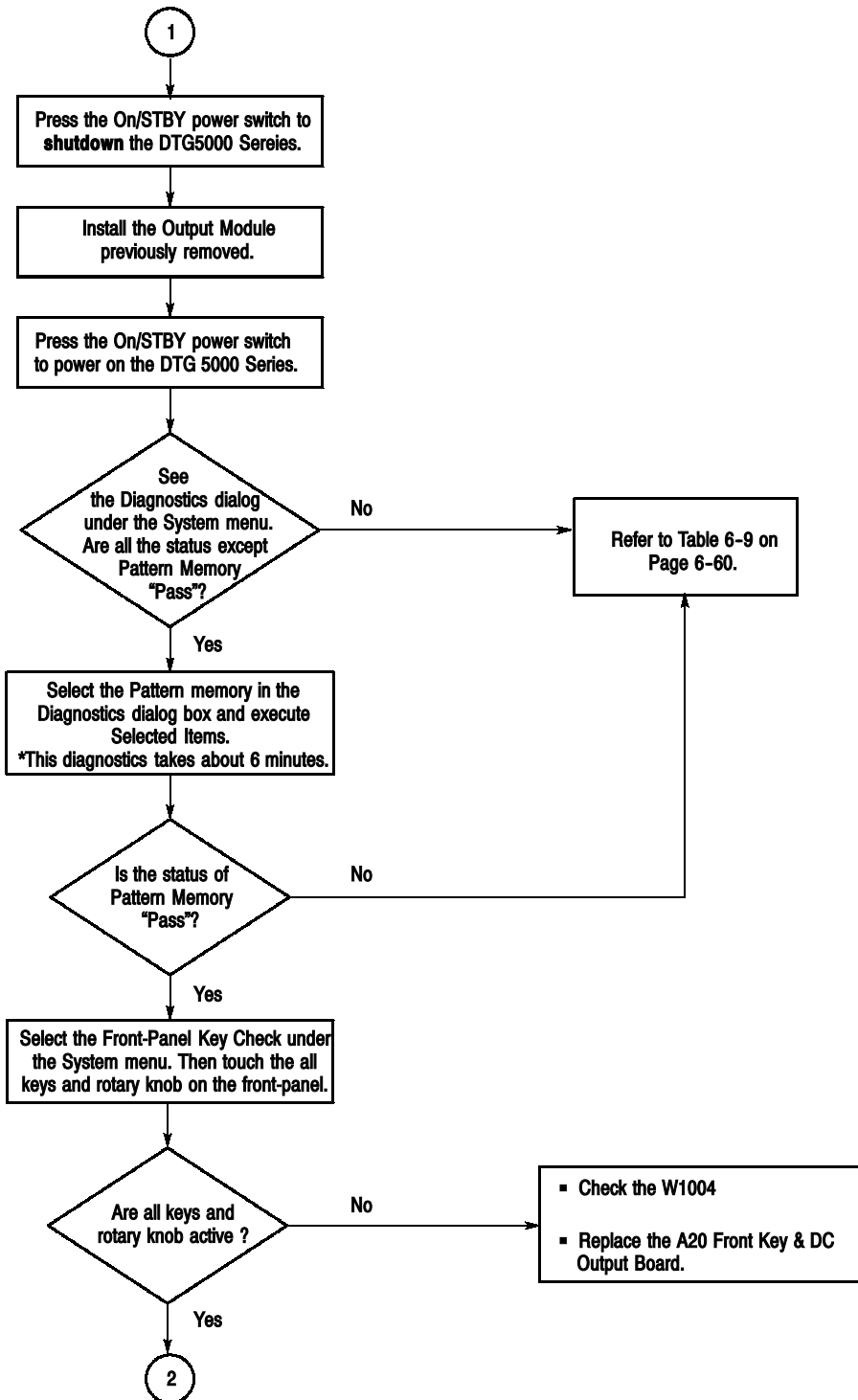

Figure 6-33: Primary troubleshooting procedure (2)

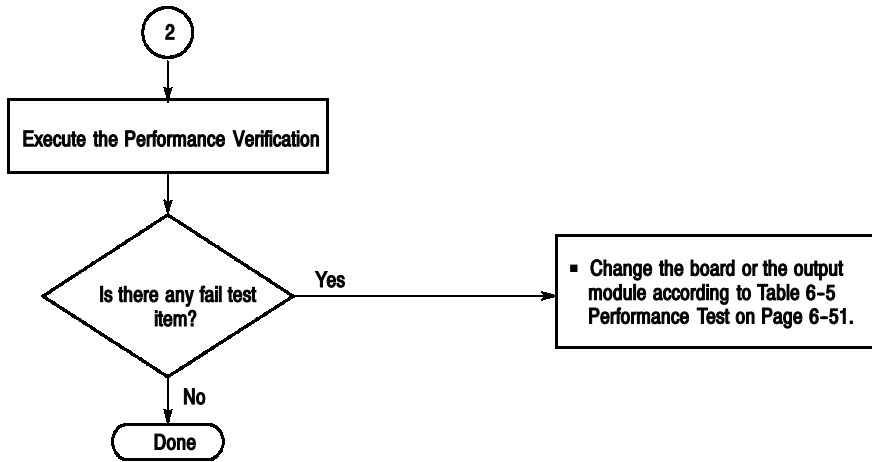

Figure 6-34: Primary troubleshooting procedure (3)

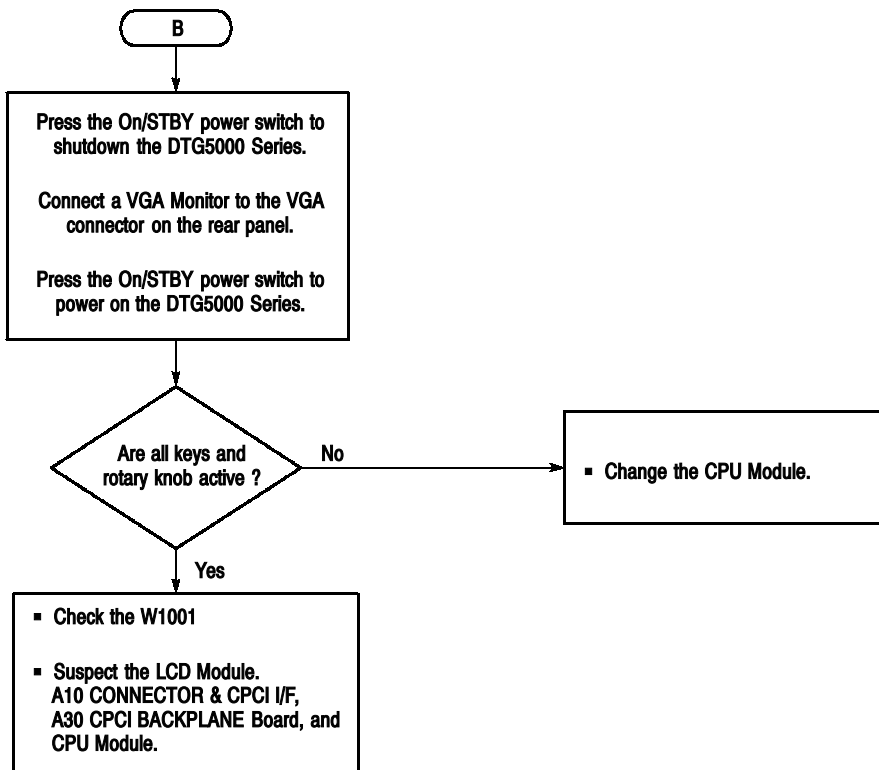

Figure 6-35: Troubleshooting procedure B — Display section

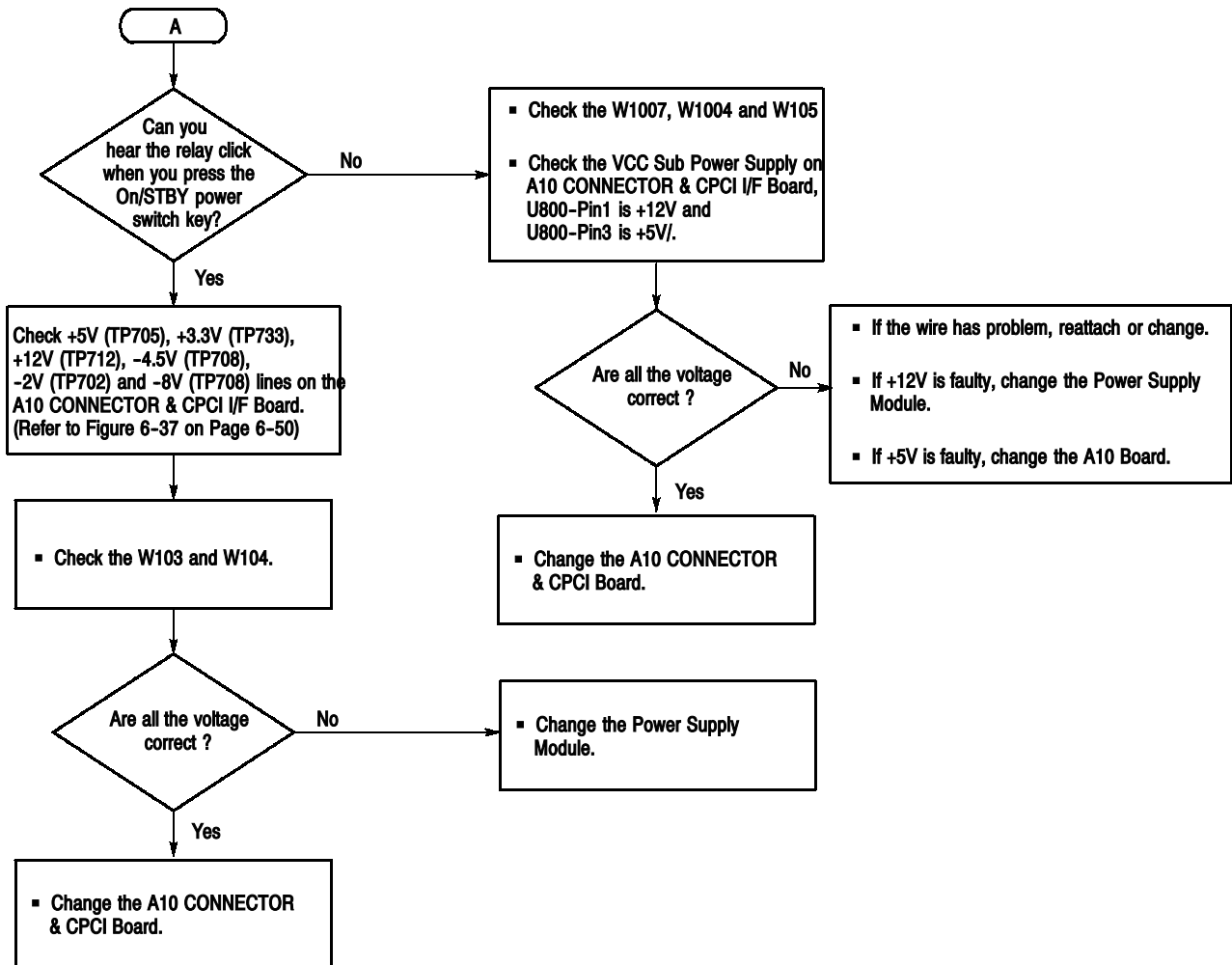

Figure 6-36: Troubleshooting procedure A - Power Supply and A10 board section

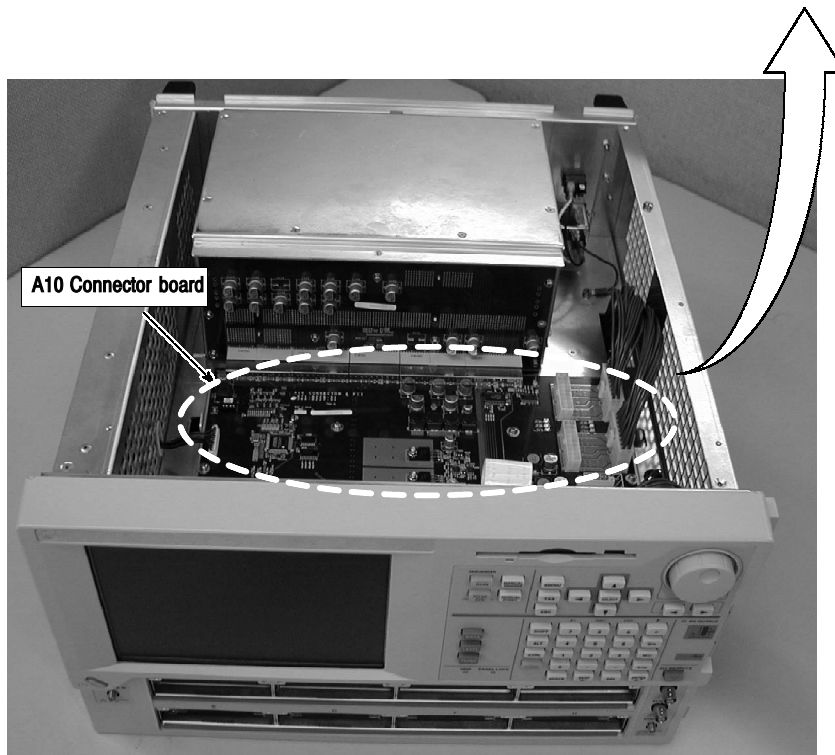
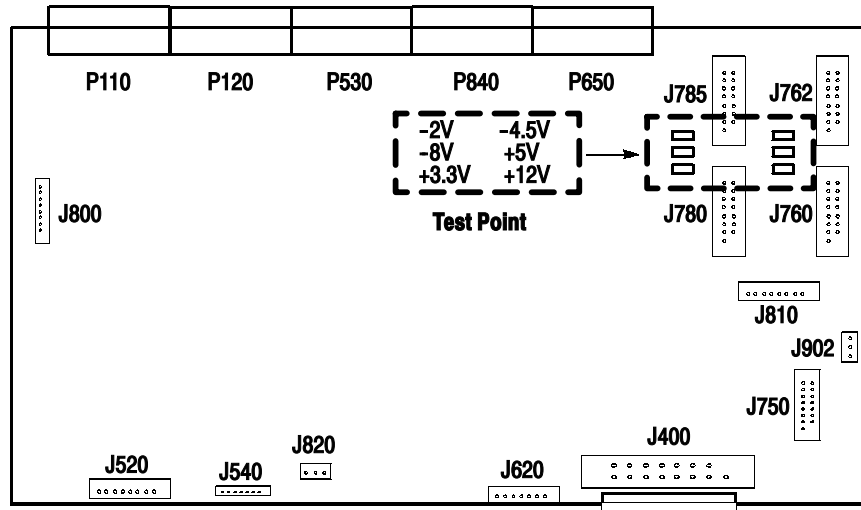

Figure 6-37: Test point on the A10 Connector board

Table 6-5: Performance Test

Performance test items	Action
DTG5000 series mainframe	
Sync output	<ul style="list-style-type: none"> ■ Check W5018I ■ DTG5078 -> Replace A54 Main board ■ DTG5274 -> Replace A50 Main board
Internal clock frequency	<ul style="list-style-type: none"> ■ Check W5002 ■ DTG5078 -> Replace A54 Main board ■ DTG5274 -> Replace A50 Main board
External clock output	<ul style="list-style-type: none"> ■ Check W5002 and W5003 ■ DTG5078 -> Replace A54 Main board ■ DTG5274 -> Replace A50 Main board
External clock input	<ul style="list-style-type: none"> ■ Check W5001 ■ DTG5078 -> Replace A54 Main board ■ DTG5274 -> Replace A50 Main board
10MHz reference input	<ul style="list-style-type: none"> ■ Check W5019 ■ DTG5078 -> Replace A54 Main board ■ DTG5274 -> Replace A50 Main board
10MHz reference output	<ul style="list-style-type: none"> ■ Check W5020 ■ DTG5078 -> Replace A54 Main board ■ DTG5274 -> Replace A50 Main board
Phase lock input	<ul style="list-style-type: none"> ■ Check W5021 ■ DTG5078 -> Replace A54 Main board ■ DTG5274 -> Replace A50 Main board
Internal automatic trigger and Trigger input	<ul style="list-style-type: none"> ■ Check W5016 ■ DTG5078 -> Replace A54 Main board ■ DTG5274 -> Replace A50 Main board
Event input and sequence function	<ul style="list-style-type: none"> ■ Check W5017, W5005, W5006, and W5007 ■ DTG5078 -> Replace A54 Main board ■ DTG5274 -> Replace A50 Main board
All jitter generation	<ul style="list-style-type: none"> ■ DTG5078 -> Replace A62 Output board ■ DTG5274 -> Replace A60 Output board
Partial jitter generation	<ul style="list-style-type: none"> ■ DTG5078 -> Replace A62 Output board ■ DTG5274 -> Replace A60 Output board
DC output	<ul style="list-style-type: none"> ■ Replace the A20 Front Key & DC Output Board
Skew and delay timing	<ul style="list-style-type: none"> ■ DTG5078 -> Replace A62 Output board ■ DTG5274 -> Replace A60 Output board
Clock out random jitter	<ul style="list-style-type: none"> ■ DTG5078 -> Replace A54 Main board ■ DTG5274 -> Replace A50 Main board

Table 6-5: Performance Test (cont.)

Performance test items	Action
Random jitter	<ul style="list-style-type: none"> ■ DTG5078 -> Replace DTGM30, A62 (Slot A to Slot D) Output board or A63 (Slot E to Slot H) Output board, and A54 Main board by turns. ■ DTG5274 -> Replace DTGM30, A60 Output board, and A50 Main board by turns.
Total jitter	<ul style="list-style-type: none"> ■ DTG5078 -> Replace DTGM30, A62 (Slot A to Slot D) Output board or A63 (Slot E to Slot H) Output board, and A54 Main board by turns. ■ DTG5274 -> Replace DTGM30, A60 Output board, and A50 Main board by turns.
Master-Slave operation	<ul style="list-style-type: none"> ■ Check W5008, W5009, W5010, W5011, W5012, W5013, W5014(DTG5078 only), and W5015(DTG5078 only). ■ DTG5078 -> Replace A54 Main board ■ DTG5274 -> Replace A50 Main board
Output module	
Data output DC level	<ul style="list-style-type: none"> ■ Replace the Output Module
Data format	<ul style="list-style-type: none"> ■ DTG5078 -> Replace A54 Main board ■ DTG5274 -> Replace A50 Main board

Diagnostics

The data timing generator has two levels of internal diagnostics that focus on verifying and isolating faulty modules.

Both levels of internal diagnostics report any bad modules and/or interfaces. If a bad module and/or interface is found, use the troubleshooting procedures in this section to determine which module needs to be replaced.

The two levels of diagnostics are the power on diagnostics and the manual diagnostics. Both of diagnostics of the data timing generator diagnoses the following items:

- Registers
- Clocks
- Outputs
- Sequence memory
- Pattern memory

Power On Diagnostic Test

When you power on the DTG5000 Series, it automatically executes a diagnostic test for all the diagnostics items, except the pattern memory cell test, while the Startup window remains on-screen. When detecting an error, this test displays an error message. If you see such a message, press the **ENTER** key and click the **OK** button to proceed with the next step. The DTG5000 software starts. When the DTG5000 Series contains an unsolved error, the test cannot be conducted normally.

Diagnostic Test from Menu

When you select **Diagnostics...** in the **System** menu, the Diagnostics dialog box appears. This box lists the results of the power-on or the latest diagnostic test. This test allows you to select the desired diagnostic items and the number of repetitions. Figure 6-38 shows a diagnostics dialog box of 1 master and no-slave configuration.

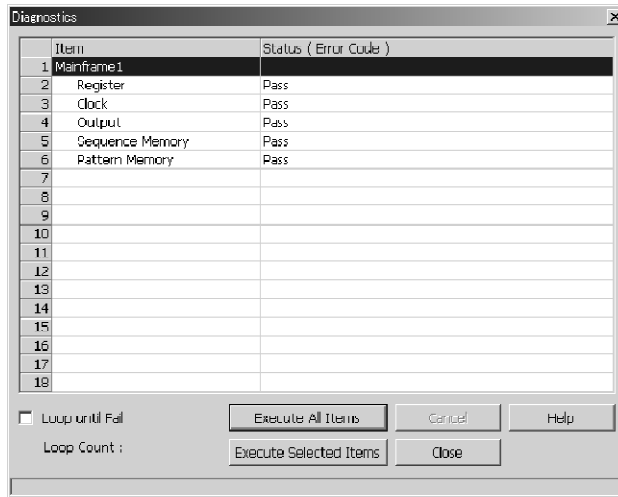

Figure 6-38: Diagnostics dialog box

The buttons and check box available in the dialog box are described in Table 6-6.

Table 6-6: Diagnostics dialog box buttons

Button	Description
Execute All Items	Executes diagnostics on all the test items.
Execute Selected Items	Executes diagnostics on one or more consecutive test items you selected. To select a test item, use the Up and/or Down arrow key. To select two or more items, use the Up and/or Down arrow key while holding down the SHIFT key.
Loop until Fail	If you select this checkbox, the diagnostic test repeats until it detects any fail. To cancel the test, click the Cancel button.
Cancel	Stops the test that is running. Available only during the test.
Close	Closes the dialog box.

Diagnostics Items The diagnostics investigate the following items.

NOTE. *DTG5274 uses the A50 and A60 boards. DTG5078 uses the A54 , A62 and A63 boards.*

DTGM10 uses the A74 board, DTGM20 uses the A72 board and DTGM30 uses the A70 board.

Register checks the following:

- For A50 or A54 board

Perform the write and read back check of register in which read/write is possible.

Perform the write and read back check of the EVENT RAM.

Perform the check of the data in the EEPROM.

- For A60 or A62 or A63 board

Perform the write and read back check of register in which read/write is possible.

Perform the write and read back check of the Jitter Waveform Memory.

Perform the check of the data in the EEPROM.

- For A70 or A72 or A74 board

Perform the write and read back check of register in which read/write is possible.

Clock checks the following:

- PLL

Set the maximum frequency to DDS, and check the Lock/Unlock signal generated from PLL, and then check it at the minimum frequency.

Output: checks the following:

- Reference Level

Measure the reference voltage of DAC for output level and make sure that the result is within the allowance level.

- Output Level

Measure the output voltage and make sure that the result is within the allowance level.

- **DLY10 Delay Time**

Measure the delay time for every bit of DLY10 and make sure that the result is within the allowance level.

Does not perform this check for the slot E, F, G and H in the DTG5078 because these slots use another type of delay lines.

Sequence Memory checks the following:

- **Data Bus**

Make sure that there is no error by executing the data bus test for the sequence memory.

- **Address Bus**

Make sure that there is no error by executing the address bus test for the sequence memory.

- **Memory Cell**

Make sure that there is no error by reading the written data after writing test pattern data to all the memory cells of the sequence memory.

Pattern Memory checks the following:

- **Data Bus**

Make sure that there is no error by executing the data bus test for the pattern memory.

- **Address Bus**

Make sure that there is no error by executing the address bus test for the pattern memory.

- **Memory Cell**

Make sure that there is no error by reading the written data after writing test pattern data to all the memory cells of the pattern memory.

Operating Procedure

1. Select **Diagnostics...** in the **System** menu, the Diagnostics dialog box appears.
2. If you want to execute all the test items, click the **Execute All Items** button to start the diagnostics.

If you want to execute only the desired test items, select them by using the Up and/or Down arrow keys holding the **SHIFT** button, and then click the **Execute Selected Item** button to start the diagnostics.

If you select the **Loop Until Fail** checkbox, the diagnostic test repeats until it detects Fail.

NOTE. The diagnostic test resets all the hardware settings to the defaults. Before the test begins, you see a confirmation dialog box that asks you whether you want to save the current settings. Choose to save the settings, if necessary.

The internal diagnostics do an exhaustive verification of proper function. This verification takes several minutes.

3. When the test is finished, the results are listed. Select the **Close** button. Then, press the **ENTER** key to close the dialog box.

Diagnostic Results

Status lists the diagnostic results. When the DTG5000 Series contains an unsolved error, it cannot operate normally.

Table 6-7: Information on Status

Status	Description
Pass	The DTG5000 Series is operating normally.
Unknown	The results are unknown because the test has not finished yet. As the power-on diagnostic test can diagnose only part of the pattern memory, so this message is displayed in Pattern Memory section.
Fail (xxxxxxx)	The test detected an error. xxxxxx represents an error code.
Executing	Now executing.

Error Codes If Diagnostics detects a malfunction, it displays character string “Fail” and the error code. The error code consists of a five-digit code and three arguments. The five-digit code consists of the mainframe number, the category, and the board and slot positions. The three arguments include supplementary information which depends on the code.

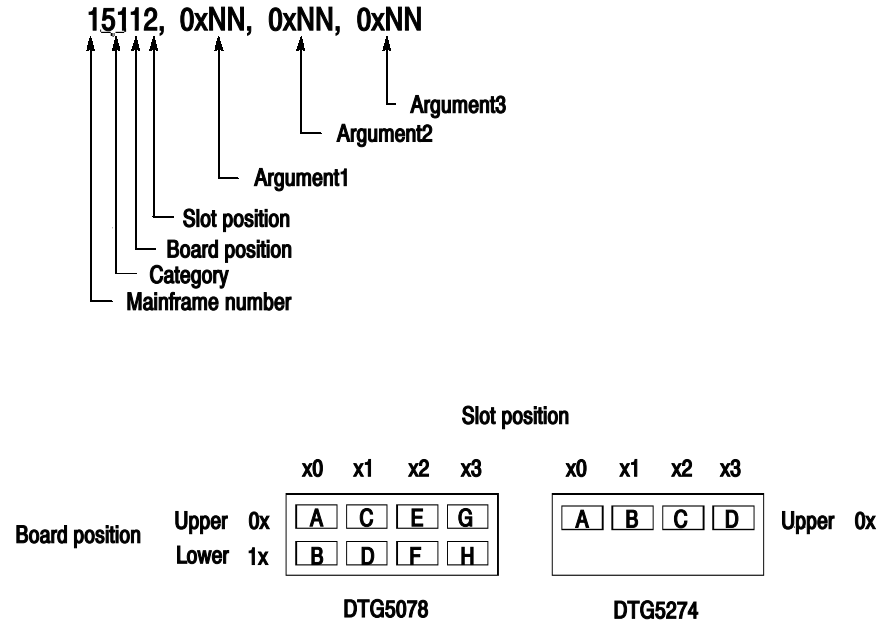

Figure 6-39: Diagnostics error code format

Table 6-8 describes the Category of the Diagnostics Error Code shown in Figure 6-39. and Table 6-9 shows the error code and related modules coming up for failure.

Table 6-8: Category of the Diagnostics Error Code

Category		Description	
Register	10	For A50/A54	Register Read/Write Fail
	11		Sequence FPGA Register Read/Write Fail
	12		Sequence FPGA Event RAM Read/Write Fail
	13		EEPROM CAL Data Checksum Fail
Register	20	For A60/A62/A63	Register Read/Write Fail
	21		Jitter Waveform RAM Read/Write Fail
	22		EEPROM CAL Data Checksum Fail
Register	30	For A70/A72/A74	A70/A72/A74 Register Read/Write Fail
Clock	40	PLL	Clock PLL Lock/Unlock Fail
Output	50	Reference Level	Output DAC Reference Fail
	51	Output Level	Output Level Fail
	52	DLY10 Delay Level	Output Delay Fail
Sequence Memory	60	Data Bus	Sequence Memory Data Bus Fail
	61	Address Bus	Sequence Memory Address Bus Fail
	62	Memory Bus	Sequence Memory Cell Fail
Pattern Memory	70	Data Bus	Sequence Memory Data Bus Fail
	71	Address Bus	Sequence Memory Address Bus Fail
	72	Memory Bus	Sequence Memory Cell Fail

Table 6-9 shows the error code and related modules coming up for failure.

Table 6-9: Error Codes

Error code	Description	Argument1	Argument2	Argument3	Related module
	<i>/*--- Register Diagnostics ---*/</i>				
11000	Mainframe1 A50/A54 Register Read/Write Fail	This code means failed address	This code means failed address	This code means failed address	DTG5078: A54 or A10 DTG5274: A50 or A10
11100	Mainframe1 A50/A54 Sequence FPGA Register Read/Write Fail	same as above	same as above	same as above	DTG5078: A54 or A10 DTG5274: A50 or A10
11200	Mainframe1 A50/A54 Sequence FPGA Event RAM Read/Write Fail	same as above	same as above	same as above	DTG5078: A54 or A10 DTG5274: A50 or A10
11300	Mainframe1 A50/A54 EEPROM CAL Data Checksum Fail	same as above	same as above	same as above	DTG5078: A54 or A10 DTG5274: A50 or A10
12000	Mainframe1 A60/A63 Register Read/Write Fail	same as above	same as above	same as above	DTG5078: A63 or A54 or W6200 DTG5274: A60 or A50 or W6000
12010	Mainframe1 A62 Register Read/Write Fail	same as above	same as above	same as above	DTG5078: A62 or A54 or W6200
12100	Mainframe1 A60/A63 Jitter Waveform RAM Read/Write Fail	same as above	same as above	same as above	DTG5078: A63 DTG5274: A60
12110	Mainframe1 A62 Jitter Waveform RAM Read/Write Fail	same as above	same as above	same as above	DTG5078: A62
12200	Mainframe1 A60/A63 EEPROM CAL Data Checksum Fail	same as above	same as above	same as above	DTG5078: A63 DTG5274: A60
12210	Mainframe1 A62 EEPROM CAL Data Checksum Fail	same as above	same as above	same as above	DTG5078: A62
13000	Mainframe1 A70/A72/A74 Register Read/Write Fail (The output module of Slot A)	same as above	same as above	same as above	DTGM10/DTGM20/DTGM30, or DTG5078: A63 DTG5274: A60
13001	Mainframe1 A70/A72/A74 Register Read/Write Fail (The output module of Slot B(if DTG5274)/Slot C(if DTG5078))	same as above	same as above	same as above	DTGM10/DTGM20/DTGM30, or DTG5078: A63 DTG5274: A60
13002	Mainframe1 A70/A72/A74 Register Read/Write Fail (The output module of Slot C(if DTG5274)/Slot E(if DTG5078))	same as above	same as above	same as above	DTGM10/DTGM20/DTGM30, or DTG5078: A63 DTG5274: A60
13003	Mainframe1 A70/A72/A74 Register Read/Write Fail (The output module of Slot D(if DTG5274)/Slot G(if DTG5078))	same as above	same as above	same as above	DTGM10/DTGM20/DTGM30, or DTG5078: A63 DTG5274: A60

Table 6-9: Error Codes (Cont.)

Error code	Description	Argument1	Argument2	Argument3	Related module
13010	Mainframe1 A70/A72/A74 Register Read/Write Fail (The output module of Slot B)	same as above	same as above	same as above	DTGM10/DTGM20/DTGM30, or DTG5078: A63 DTG5274: A60
13011	Mainframe1 A70/A72/A74 Register Read/Write Fail (The output module of Slot D)	same as above	same as above	same as above	DTGM10/DTGM20/DTGM30, or DTG5078: A63 DTG5274: A60
13012	Mainframe1 A70/A72/A74 Register Read/Write Fail (The output module of Slot F)	same as above	same as above	same as above	DTGM10/DTGM20/DTGM30, or DTG5078: A63 DTG5274: A60
13013	Mainframe1 A70/A72/A74 Register Read/Write Fail (The output module of Slot H)	same as above	same as above	same as above	DTGM10/DTGM20/DTGM30, or DTG5078: A63 DTG5274: A60
/*--- Clock Diagnostics ---*/					
14000	Mainframe1 Clock PLL Lock/Unlock Fail	Refer to Note(1)	—	—	DTG5078: A54 DTG5274: A50
/*--- Output Diagnostics ---*/					
15000	Mainframe1 A60/A63 Output DAC Reference Fail	0x0000:GND Level Fail 0x0001:+3V Level Fail 0x0002:-4.5V Level Fail	—	—	DTG5078: A63 DTG5274: A60
15010	Mainframe1 A62 Output DAC Reference Fail	same as above	—	—	DTG5078: A62
15100	Mainframe1 Output Level Fail(The output module of Slot A)	0x0000: CH1 failure 0x0001: CH2 failure 0x0002: CH3 failure 0x0003: CH4 failure	—	—	Inserted Output Module or DTG5078: A63 DTG5274: A60
15101	Mainframe1 Output Level Fail(The output module of Slot B(if DTG5274)/Slot C(if DTG5078))	same as above	—	—	Inserted Output Module or DTG5078: A63 DTG5274: A60
15102	Mainframe1 Output Level Fail(The output module of Slot C(if DTG5274)/Slot E(if DTG5078))	same as above	—	—	Inserted Output Module or DTG5078: A63 DTG5274: A60
15103	Mainframe1 Output Level Fail(The output module of Slot D(if DTG5274)/Slot G(if DTG5078))	same as above	—	—	Inserted Output Module or DTG5078: A63 DTG5274: A60

Table 6-9: Error Codes (Cont.)

Error code	Description	Argument1	Argument2	Argument3	Related module
15110	Mainframe1 Output Level Fail(The output module of Slot B)	same as above	—	—	Inserted Output Module or DTG5078: A62
15111	Mainframe1 Output Level Fail(The output module of Slot D)	same as above	—	—	Inserted Output Module or DTG5078: A62
15112	Mainframe1 Output Level Fail(The output module of Slot F)	same as above	—	—	Inserted Output Module or DTG5078: A62
15113	Mainframe1 Output Level Fail(The output module of Slot H)	same as above	—	—	Inserted Output Module or DTG5078: A62
15200	Mainframe1 Output Delay Fail(The output module of Slot A)	same as above	—	—	DTG5078: A63 DTG5274: A60
15201	Mainframe1 Output Delay Fail(The output module of Slot B(if DTG5274)/Slot C(if DTG5078))	same as above	—	—	DTG5078: A62 DTG5274: A60
15202	Mainframe1 Output Delay Fail(The output module of Slot C(if DTG5274)/Slot E(if DTG5078))	same as above	—	—	DTG5078: A63 DTG5274: A60
15203	Mainframe1 Output Delay Fail(The output module of Slot D(if DTG5274)/Slot G(if DTG5078))	same as above	—	—	DTG5078: A62 DTG5274: A60
15210	Mainframe1 Output Delay Fail(The output module of Slot B)	same as above	—	—	DTG5078: A62
15211	Mainframe1 Output Delay Fail(The output module of Slot D)	same as above	—	—	DTG5078: A62
15212	Mainframe1 Output Delay Fail(The output module of Slot F)	same as above	—	—	DTG5078: A62
15213	Mainframe1 Output Delay Fail(The output module of Slot H)	same as above	—	—	DTG5078: A62
	/*Sequence Memory Diagnostics*/				
16000	Mainframe1 Sequence Memory Data Bus Fail	Failed address	Write data	Read data	DTG5078: A54 DTG5274: A50
16100	Mainframe1 Sequence Memory Address Bus Fail	same as above	same as above	same as above	DTG5078: A54 DTG5274: A50
16200	Mainframe1 Sequence Memory Cell Fail	same as above	same as above	same as above	DTG5078: A54 DTG5274: A50
	/*- Pattern Memory Diagnostics -*/				
17000	Mainframe1 Pattern Memory Data Bus Fail	Failed address	Write data	Write data	DTG5078: A54 DTG5274: A50
17100	Mainframe1 Pattern Memory Address Bus Fail	same as above	same as above	same as above	DTG5078: A54 DTG5274: A50

Table 6-9: Error Codes (Cont.)

Error code	Description	Argument1	Argument2	Argument3	Related module
17200	Mainframe1 Pattern Memory Cell Fail	same as above	same as above	same as above	DTG5078: A54 DTG5274: A50
	/*--- Register Diagnostics ---*/				
21000	Mainframe2 A50/A54 Register Read/Write Fail	This code mean failed address	This code mean failed address	This code mean failed address	DTG5078: A54 or A10 DTG5274: A50 or A10
21100	Mainframe2 A50/A54 Sequence FPGA Register Read/Write Fail	same as above	same as above	same as above	DTG5078: A54 or A10 DTG5274: A50 or A10
21200	Mainframe2 A50/A54 Sequence FPGA Event RAM Read/Write Fail	same as above	same as above	same as above	DTG5078: A54 or A10 DTG5274: A50 or A10
21300	Mainframe2 A50/A54 EEPROM CAL Data Checksum Fail	same as above	same as above	same as above	DTG5078: A54 or A10 DTG5274: A50 or A10
22000	Mainframe2 A60/A63 Register Read/Write Fail	same as above	same as above	same as above	DTG5078: A63 or A54 or W6200 DTG5274: A60 or A50 or W6000
22010	Mainframe2 A62 Register Read/Write Fail	same as above	same as above	same as above	DTG5078: A62 or A54 or W6200
22100	Mainframe2 A60/A63 Jitter Waveform RAM Read/Write Fail	same as above	same as above	same as above	DTG5078: A63 DTG5274: A60
22110	Mainframe2 A62 Jitter Waveform RAM Read/Write Fail	same as above	same as above	same as above	DTG5078: A62
22200	Mainframe2 A60/A63 EEPROM CAL Data Checksum Fail	same as above	same as above	same as above	DTG5078: A63 DTG5274: A60
22210	Mainframe2 A62 EEPROM CAL Data Checksum Fail	same as above	same as above	same as above	DTG5078: A62
23000	Mainframe2 A70/A72/A74 Register Read/Write Fail (The output module of Slot A)	same as above	same as above	same as above	DTGM10/DTGM20/DTGM30, or DTG5078: A63 DTG5274: A60
23001	Mainframe2 A70/A72/A74 Register Read/Write Fail (The output module of Slot B(if DTG5274)/Slot C(if DTG5078))	same as above	same as above	same as above	DTGM10/DTGM20/DTGM30, or DTG5078: A63 DTG5274: A60
23002	Mainframe2 A70/A72/A74 Register Read/Write Fail (The output module of Slot C(if DTG5274)/Slot E(if DTG5078))	same as above	same as above	same as above	DTGM10/DTGM20/DTGM30, or DTG5078: A63 DTG5274: A60
23003	Mainframe2 A70/A72/A74 Register Read/Write Fail (The output module of Slot D(if DTG5274)/Slot G(if DTG5078))	same as above	same as above	same as above	DTGM10/DTGM20/DTGM30, or DTG5078: A63 DTG5274: A60
23010	Mainframe2 A70/A72/A74 Register Read/Write Fail (The output module of Slot B)	same as above	same as above	same as above	DTGM10/DTGM20/DTGM30, or DTG5078: A63 DTG5274: A60

Table 6-9: Error Codes (Cont.)

Error code	Description	Argument1	Argument2	Argument3	Related module
23011	Mainframe2 A70/A72/A74 Register Read/Write Fail (The output module of Slot D)	same as above	same as above	same as above	DTGM10/DTGM20/DTGM30, or DTG5078: A63 DTG5274: A60
23012	Mainframe2 A70/A72/A74 Register Read/Write Fail (The output module of Slot F)	same as above	same as above	same as above	DTGM10/DTGM20/DTGM30, or DTG5078: A63 DTG5274: A60
23013	Mainframe2 A70/A72/A74 Register Read/Write Fail (The output module of Slot H)	same as above	same as above	same as above	DTGM10/DTGM20/DTGM30, or DTG5078: A63 DTG5274: A60
/*--- Clock Diagnostics ---*/					
24000	Mainframe2 Clock PLL Lock/Unlock Fail	Refer to Note(1)	—	—	DTG5078: A54 DTG5274: A50
/*--- Output Diagnostics ---*/					
25000	Mainframe2 A60/A63 Output DAC Reference Fail	0x0000:GND Level Fail 0x0001:+3V Level Fail 0x0002:-4.5V Level Fail	—	—	DTG5078: A63 DTG5274: A60
25010	Mainframe2 A62 Output DAC Reference Fail	same as above	—	—	DTG5078: A62
25100	Mainframe2 Output Level Fail(The output module of Slot A)	0x0000: CH1 failure 0x0001: CH2 failure 0x0002: CH3 failure 0x0003: CH4 failure	—	—	Inserted Output Module or DTG5078: A63 DTG5274: A60
25101	Mainframe2 Output Level Fail(The output module of Slot B(if DTG5274)/Slot C(if DTG5078))	same as above	—	—	Inserted Output Module or DTG5078: A63 DTG5274: A60
25102	Mainframe2 Output Level Fail(The output module of Slot C(if DTG5274)/Slot E(if DTG5078))	same as above	—	—	Inserted Output Module or DTG5078: A63 DTG5274: A60
25103	Mainframe2 Output Level Fail(The output module of Slot D(if DTG5274)/Slot G(if DTG5078))	same as above	—	—	Inserted Output Module or DTG5078: A63 DTG5274: A60
25110	Mainframe2 Output Level Fail(The output module of Slot B)	same as above	—	—	Inserted Output Module or DTG5078: A62
25111	Mainframe2 Output Level Fail(The output module of Slot D)	same as above	—	—	Inserted Output Module or DTG5078: A62

Table 6-9: Error Codes (Cont.)

Error code	Description	Argument1	Argument2	Argument3	Related module
25112	Mainframe2 Output Level Fail(The output module of Slot F)	same as above	—	—	Inserted Output Module or DTG5078: A62
25113	Mainframe2 Output Level Fail(The output module of Slot H)	same as above	—	—	Inserted Output Module or DTG5078: A62
25200	Mainframe2 Output Delay Fail(The output module of Slot A)	same as above	—	—	DTG5078: A63 DTG5274: A60
25201	Mainframe2 Output Delay Fail(The output module of Slot B(if DTG5274)/Slot C(if DTG5078))	same as above	—	—	DTG5078: A62 DTG5274: A60
25202	Mainframe2 Output Delay Fail(The output module of Slot C(if DTG5274)/Slot E(if DTG5078))	same as above	—	—	DTG5078: A63 DTG5274: A60
25203	Mainframe2 Output Delay Fail(The output module of Slot D(if DTG5274)/Slot G(if DTG5078))	same as above	—	—	DTG5078: A62 DTG5274: A60
25210	Mainframe2 Output Delay Fail(The output module of Slot B)	same as above	—	—	DTG5078: A62
25211	Mainframe2 Output Delay Fail(The output module of Slot D)	same as above	—	—	DTG5078: A62
25212	Mainframe2 Output Delay Fail(The output module of Slot F)	same as above	—	—	DTG5078: A62
25213	Mainframe2 Output Delay Fail(The output module of Slot H)	same as above	—	—	DTG5078: A62
	/*Sequence Memory Diagnostics*/				
26000	Mainframe2 Sequence Memory Data Bus Fail	Failed address	Write data	Read data	DTG5078: A54 DTG5274: A50
26100	Mainframe2 Sequence Memory Address Bus Fail	same as above	same as above	same as above	DTG5078: A54 DTG5274: A50
26200	Mainframe2 Sequence Memory Cell Fail	same as above	same as above	same as above	DTG5078: A54 DTG5274: A50
	/*- Pattern Memory Diagnostics -*/				
27000	Mainframe2 Pattern Memory Data Bus Fail	Fail address	Write data	Write data	DTG5078: A54 DTG5274: A50
27100	Mainframe2 Pattern Memory Address Bus Fail	same as above	same as above	same as above	DTG5078: A54 DTG5274: A50
27200	Mainframe2 Pattern Memory Cell Fail	same as above	same as above	same as above	DTG5078: A54 DTG5274: A50
	/*--- Register Diagnostics ---*/				

Table 6-9: Error Codes (Cont.)

Error code	Description	Argument1	Argument2	Argument3	Related module
31000	Mainframe3 A50/A54 Register Read/Write Fail	This code mean failed address	This code mean failed address	This code mean failed address	DTG5078: A54 or A10 DTG5274: A50 or A10
31100	Mainframe3 A50/A54 Sequence FPGA Register Read/Write Fail	same as above	same as above	same as above	DTG5078: A54 or A10 DTG5274: A50 or A10
31200	Mainframe3 A50/A54 Sequence FPGA Event RAM Read/Write Fail	same as above	same as above	same as above	DTG5078: A54 or A10 DTG5274: A50 or A10
31300	Mainframe3 A50/A54 EEPROM CAL Data Checksum Fail	same as above	same as above	same as above	DTG5078: A54 or A10 DTG5274: A50 or A10
32000	Mainframe3 A60/A63 Register Read/Write Fail	same as above	same as above	same as above	DTG5078: A63 or A54 or W6200 DTG5274: A60 or A50 or W6000
32010	Mainframe3 A62 Register Read/Write Fail	same as above	same as above	same as above	DTG5078: A62 or A54 or W6200
32100	Mainframe3 A60/A63 Jitter Waveform RAM Read/Write Fail	same as above	same as above	same as above	DTG5078: A63 DTG5274: A60
32110	Mainframe3 A62 Jitter Waveform RAM Read/Write Fail	same as above	same as above	same as above	DTG5078: A62
32200	Mainframe3 A60/A63 EEPROM CAL Data Checksum Fail	same as above	same as above	same as above	DTG5078: A63 DTG5274: A60
32210	Mainframe3 A62 EEPROM CAL Data Checksum Fail	same as above	same as above	same as above	DTG5078: A62
33000	Mainframe3 A70/A72/A74 Register Read/Write Fail (The output module of Slot A)	same as above	same as above	same as above	DTGM10/DTGM20/DTGM30, or DTG5078: A63 DTG5274: A60
33001	Mainframe3 A70/A72/A74 Register Read/Write Fail (The output module of Slot B(if DTG5274)/Slot C(if DTG5078))	same as above	same as above	same as above	DTGM10/DTGM20/DTGM30, or DTG5078: A63 DTG5274: A60
33002	Mainframe3 A70/A72/A74 Register Read/Write Fail (The output module of Slot C(if DTG5274)/Slot E(if DTG5078))	same as above	same as above	same as above	DTGM10/DTGM20/DTGM30, or DTG5078: A63 DTG5274: A60
33003	Mainframe3 A70/A72/A74 Register Read/Write Fail (The output module of Slot D(if DTG5274)/Slot G(if DTG5078))	same as above	same as above	same as above	DTGM10/DTGM20/DTGM30, or DTG5078: A63 DTG5274: A60
33010	Mainframe3 A70/A72/A74 Register Read/Write Fail (The output module of Slot B)	same as above	same as above	same as above	DTGM10/DTGM20/DTGM30, or DTG5078: A63 DTG5274: A60
33011	Mainframe3 A70/A72/A74 Register Read/Write Fail (The output module of Slot D)	same as above	same as above	same as above	DTGM10/DTGM20/DTGM30, or DTG5078: A63 DTG5274: A60

Table 6-9: Error Codes (Cont.)

Error code	Description	Argument1	Argument2	Argument3	Related module
33012	Mainframe3 A70/A72/A74 Register Read/Write Fail (The output module of Slot F)	same as above	same as above	same as above	DTGM10/DTGM20/DTGM30, or DTG5078: A63 DTG5274: A60
33013	Mainframe3 A70/A72/A74 Register Read/Write Fail (The output module of Slot H)	same as above	same as above	same as above	DTGM10/DTGM20/DTGM30, or DTG5078: A63 DTG5274: A60
/*--- Clock Diagnostics ---*/					
34000	Mainframe3 Clock PLL Lock/Unlock Fail	Refer to Note(1)	—	—	DTG5078: A54 DTG5274: A50
/*--- Output Diagnostics ---*/					
35000	Mainframe3 A60/A63 Output DAC Reference Fail	0x0000:GND Level Fail 0x0001:+3V Level Fail 0x0002:-4.5V Level Fail	—	—	DTG5078: A63 DTG5274: A60
35010	Mainframe3 A62 Output DAC Reference Fail	same as above	—	—	DTG5078: A62
35100	Mainframe3 Output Level Fail(The output module of Slot A)	0x0000: CH1 failure 0x0001: CH2 failure 0x0002: CH3 failure 0x0003: CH4 failure	—	—	Inserted Output Module or DTG5078: A63 DTG5274: A60
35101	Mainframe3 Output Level Fail(The output module of Slot B(if DTG5274)/Slot C(if DTG5078))	same as above	—	—	Inserted Output Module or DTG5078: A63 DTG5274: A60
35102	Mainframe3 Output Level Fail(The output module of Slot C(if DTG5274)/Slot E(if DTG5078))	same as above	—	—	Inserted Output Module or DTG5078: A63 DTG5274: A60
35103	Mainframe3 Output Level Fail(The output module of Slot D(if DTG5274)/Slot G(if DTG5078))	same as above	—	—	Inserted Output Module or DTG5078: A63 DTG5274: A60
35110	Mainframe3 Output Level Fail(The output module of Slot B)	same as above	—	—	Inserted Output Module or DTG5078: A62
35111	Mainframe3 Output Level Fail(The output module of Slot D)	same as above	—	—	Inserted Output Module or DTG5078: A62
35112	Mainframe3 Output Level Fail(The output module of Slot F)	same as above	—	—	Inserted Output Module or DTG5078: A62

Table 6-9: Error Codes (Cont.)

Error code	Description	Argument1	Argument2	Argument3	Related module
35113	Mainframe3 Output Level Fail(The output module of Slot H)	same as above	—	—	Inserted Output Module or DTG5078: A62
35200	Mainframe3 Output Delay Fail(The output module of Slot A)	same as above	—	—	DTG5078: A63 DTG5274: A60
35201	Mainframe3 Output Delay Fail(The output module of Slot B(if DTG5274)/Slot C(if DTG5078))	same as above	—	—	DTG5078: A62 DTG5274: A60
35202	Mainframe3 Output Delay Fail(The output module of Slot C(if DTG5274)/Slot E(if DTG5078))	same as above	—	—	DTG5078: A63 DTG5274: A60
35203	Mainframe3 Output Delay Fail(The output module of Slot D(if DTG5274)/Slot G(if DTG5078))	same as above	—	—	DTG5078: A62 DTG5274: A60
35210	Mainframe3 Output Delay Fail(The output module of Slot B)	same as above	—	—	DTG5078: A62
35211	Mainframe3 Output Delay Fail(The output module of Slot D)	same as above	—	—	DTG5078: A62
35212	Mainframe3 Output Delay Fail(The output module of Slot F)	same as above	—	—	DTG5078: A62
35213	Mainframe3 Output Delay Fail(The output module of Slot H)	same as above	—	—	DTG5078: A62
	/*Sequence Memory Diagnostics*/				
36000	Mainframe3 Sequence Memory Data Bus Fail	Failed address	Write data	Read data	DTG5078: A54 DTG5274: A50
36100	Mainframe3 Sequence Memory Address Bus Fail	same as above	same as above	same as above	DTG5078: A54 DTG5274: A50
36200	Mainframe3 Sequence Memory Cell Fail	same as above	same as above	same as above	DTG5078: A54 DTG5274: A50
	/*- Pattern Memory Diagnostics -*/				
37000	Mainframe3 Pattern Memory Data Bus Fail	Failed address	Write data	Write data	DTG5078: A54 DTG5274: A50
37100	Mainframe3 Pattern Memory Address Bus Fail	same as above	same as above	same as above	DTG5078: A54 DTG5274: A50
37200	Mainframe3 Pattern Memory Cell Fail	same as above	same as above	same as above	DTG5078: A54 DTG5274: A50

System Recovery

If the operating system does not start up, you have to recover the OS by starting it from the recovery disk supplied with the OS. Recovering the system using the recovery disk deletes all data from the hard disk.

For this reason, you have to perform the following operations:

- Reinstalling the Windows 2000 operating system
- Setting up the Windows 2000 operating system
- Reinstalling the DTG5000 software

Requirements for System Recovery

Prepare the following:

- Recovery disk labeled “Windows 2000 Professional Operating System Recovery Disk”
- Application installation disk labeled “DTG5000 Series Product Software”

The system cannot recognize any USB device during operation with the recovery disk. Thus prepare the following as well:

- PS/2 keyboard and PS/2 mouse

Operating Procedure



CAUTION. Recovering the system using the recovery disk deletes all data on the hard disks.
Back up the necessary data on a routine basis to avoid data loss.

Installing the Windows 2000 Operating System

1. With the power off, connect the PS/2 keyboard and PS/2 mouse to the connectors on the rear panel.
2. Power on the unit.
3. Load the recovery CD-ROM in the CD-ROM drive on the rear panel.

4. Power off the DTG5000 Series once. Then power it on again. The system starts from the recovery disk.
5. The “PowerQuest EasyRestore End User License Agreement” window appears.
Press any key as instructed in the message.
6. The EasyRestore dialog box opens. Click the **Continue** button.
7. The Warning dialog box opens. Click **Yes**.
8. After the entire image data in the drive has been copied, the Reboot dialog box opens. Remove the recovery CD-ROM from the drive, and then click the **Reboot** button.
9. The system restarts, and Windows 2000 Setup begins.
Go to the next step, “Setting Up Windows 2000.”

Setting Up Windows 2000

1. The Windows 2000 setup wizard “Welcome to the Windows 2000 Setup Wizard” appears on the data timing generator screen.
2. Click the Next button, the “License Agreement” dialog box appears.
3. Follow the on-screen instructions.
4. When the “**Personalize Your Software**” dialog box appears, “Name” and “Organization” have added. Be sure to input “Name”. “Organization” can be left blank.
5. Click the **Next** button.
6. When “**Your Product Key**” dialog box appears, enter the bar code number which is located at the rear panel of the mainframe.
7. Click the **Next** button to display the **Date and Time Settings** dialog box.
8. Confirm that the Date and the Time Settings information is correct, and the click the **Next** button.
9. The dialog box informs you the completion of Windows 2000 setup.
10. Click **Restart Now**, and Windows runs.

The computer name is DTG5000, and you can log on the Windows 2000 as the following user name and password.

- User name: Administrator
- Password: dtg5000

If you want to add the user name, or want to change the password, always use the **Control Panel -> Users and Passwords**. For more information, consult Windows 2000 Help.

NOTE. *If you connect the second or third DTG5000 series data timing generator to the network, use different computer names for additional instruments.*

Reinstalling the DTG5000 Software

1. Load the “**DTG5000 Series Product Software CD-ROM**” in the CD-ROM drive. The installer starts automatically. If it does not start, double-click the setup.exe icon to start the installer.
2. The message “Welcome to the InstallShield Wizard for Tektronix...” appears. Click **Next**.
3. The message “InstallShield Wizard Complete” appears. Click **Finish**. Windows 2000 operating system restarts when you reinstall the system software using the system recovery disk.

Service Password

The data timing generator has its own serial number on A50/A54 Main board. This serial number is used in order to differentiate each product. When the A50/A54 Main board is exchanged, it is necessary to register this serial number.

Registration of a serial number is performed on the data timing generator as service mode and you need input the service password to enter the service mode.

Set up into the Service mode

Do the following steps to set the data timing generator into the service mode.

1. Power on the data timing generator.
2. After starting up the DTG5000 software, select **System**, and then select **Service Password...** from the menu bar. The Service Password dialog box appears.
3. Enter **1603** as a password, then select **OK** button.



Figure 6-40: Service Password dialog box

The data timing generator is set up into the service mode.

Serial number registration

After set the data timing generator into the service mode, you can register the serial number.

1. Select **System**, and then select **Set Serial Number...** from the menu bar. The Set Serial Number dialog box appears.
2. Enter a serial number labeled on the rear panel, then select **OK** button.

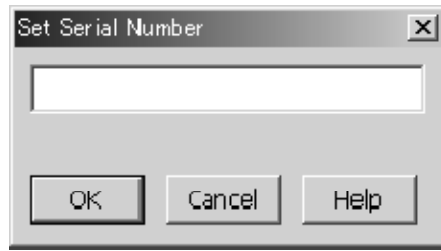

Figure 6-41: Set Serial Number dialog box



Replaceable Electrical Parts

Electrical Parts List

The modules that make up this instrument are a combination of mechanical and electrical subparts. Therefore, all replaceable modules are listed in *Replaceable Mechanical Parts*. Refer to that section for part numbers when using this manual.



Diagrams

Diagrams

This section contains following diagram:

- Block & Interconnect Diagram for the DTG5000 Series

This diagram shows the modules and functional blocks in the data timing generator. And it also shows how the modules in the data timing generator connect together.

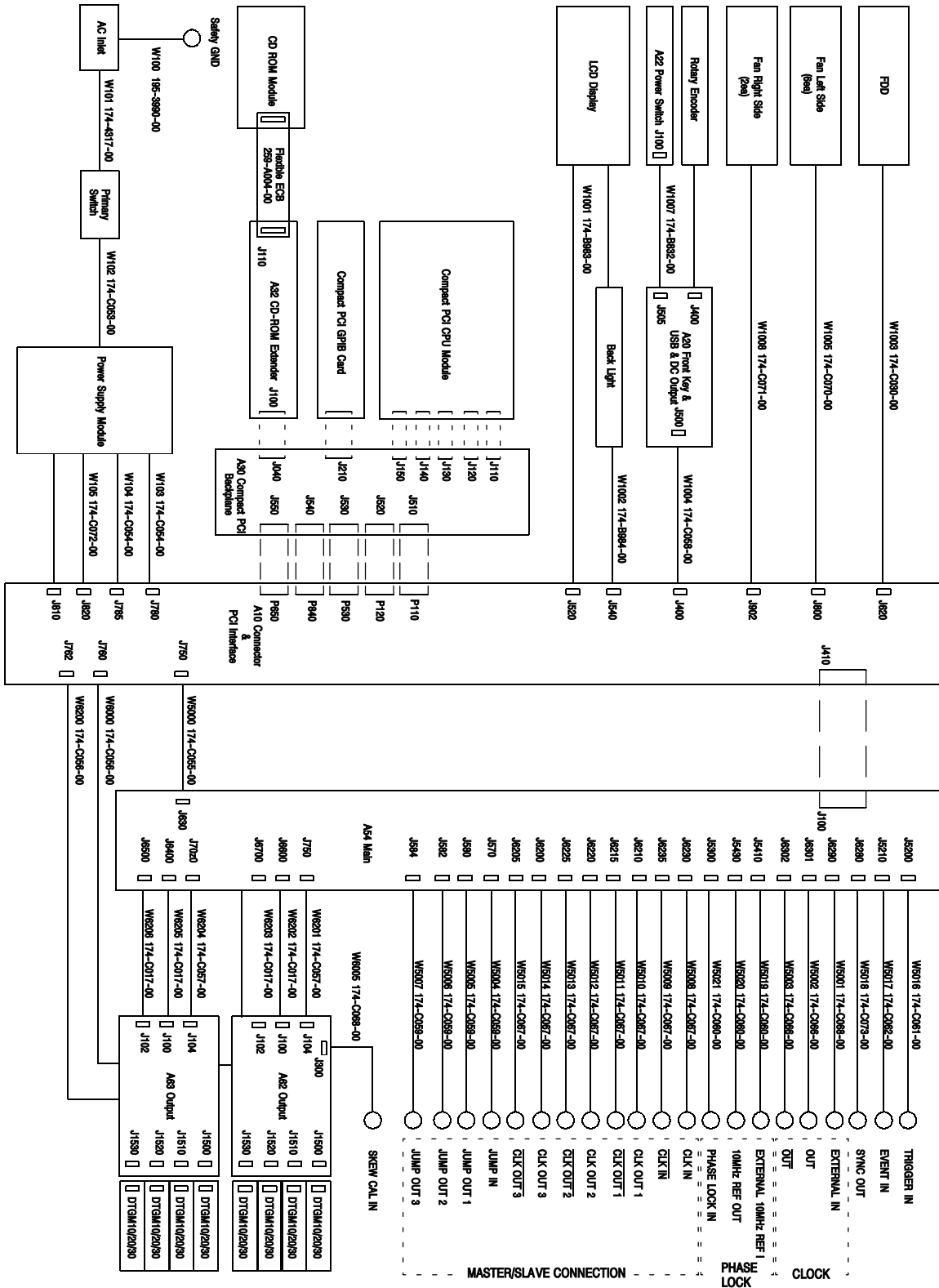

Block and interconnection for DTG5078



Replaceable Mechanical Parts

Replaceable Mechanical Parts

This section contains a list of the replaceable modules for the DTG5000 Series Data Timing Generator. Use this list to identify and order replacement parts.

Parts Ordering Information

Replacement parts are available through your local Tektronix field office or representative.

Changes to Tektronix instruments are sometimes made to accommodate improved components as they become available and to give you the benefit of the latest circuit improvements. Therefore, when ordering parts, it is important to include the following information in your order.

- Part number
- Instrument type or model number
- Instrument serial number
- Instrument modification number, if applicable

If you order a part that has been replaced with a different or improved part, your local Tektronix field office or representative will contact you concerning any change in part number.

Change information, if any, is located at the rear of this manual.

Part Number Revision Level

Tektronix part numbers contain two digits that show the revision level of the part. For most parts in this manual, you will find the letters XX in place of the revision level number.



When you order parts, Tektronix will provide you with the most current part for your product type, serial number, and modification (if applicable). At the time of your order, Tektronix will determine the part number revision level needed for your product, based on the information you provide.

Module Servicing Modules can be serviced by selecting one of the following three options. Contact your local Tektronix service center or representative for repair assistance.

Module Exchange. In some cases you may exchange your module for a remanufactured module. These modules cost significantly less than new modules and meet the same factory specifications. For more information about the module exchange program, call 1-800-TEK-WIDE, extension 6630.

Module Repair and Return. You may ship your module to us for repair, after which we will return it to you.

New Modules. You may purchase replacement modules in the same way as other replacement parts.

Using the Replaceable Parts List

This section contains a list of the mechanical and/or electrical components that are replaceable for the generator. Use this list to identify and order replacement parts. The following table describes each column in the parts list.

Parts List Column Descriptions

Column	Column name	Description
1	Figure & Index Number	Items in this section are referenced by component number.
2	Tektronix Part Number	Use this part number when ordering replacement parts from Tektronix.
3 and 4	Serial Number	Column three indicates the serial number at which the part was first effective. Column four indicates the serial number at which the part was discontinued. No entries indicates the part is good for all serial numbers.
5	Qty	This indicates the quantity of parts used.
6	Name & Description	An item name is separated from the description by a colon (:). Because of space limitations, an item name may sometimes appear as incomplete. Use the U.S. Federal Catalog handbook H6-1 for further item name identification.
7	Mfr. Code	This indicates the code of the actual manufacturer of the part. (Code to name and address cross reference is located after this page.)
8	Mfr. Part Number	This indicates the actual manufacturer's or vendor's part number.

Abbreviations Abbreviations conform to American National Standard ANSI Y1.1-1972.

Mfr. Code to Manufacturer Cross Index The following table cross indexes codes, names, and addresses of manufacturers or vendors of components listed in the parts list.

Manufacturers Cross Index

Mfr. code	Manufacturer	Address	City, state, zip code
S3109	FELLER	72 VERONICA AVE UNIT 4	SUMMERSET NJ 08873
TK0392	NORTHWEST FASTENER SALES INC	8058 SW NIMBUS AVENUE	BEAVERTON OR 97008
TK0435	LEWIS SCREW CO	4300 S RACINE AVE	CHICAGO IL 60609-3320
TK1163	POLYCAST INC	9898 SW TIGARD ST	TIGARD OR 97223
TK1287	ENOCH MFG CO	14242 SE 82ND DR PO BOX 98	CLACKAMAS OR 97015
TK1908	PLASTIC MOLDED PRODUCTS	4336 SO ADAMS	TACOMA WA 98409
TK1918	SHIN-ETSU POLYMER AMERICA INC	1181 NORTH 4TH ST	SAN JOSE CA 95112
TK2058	TDK CORPORATION OF AMERICA	1600 FEEHANVILLE DRIVE	MOUNT PROSPECT, IL 60056
TK2432	UNION ELECTRIC	15/F #1, FU-SHING N. ROAD	TAIPEI, TAIWAN ROC
TK2548	XEROX BUSINESS SERVICES DIV OF XEROX CORPORATION	14181 SW MILLIKAN WAY	BEAVERTON OR 97077
OJR05	TRIQUEST CORP	3000 LEWIS AND CLARK HWY	VANCOUVER WA 98661-2999
OKB01	STAUFFER SUPPLY	810 SE SHERMAN	PORTLAND OR 97214
00779	AMP INC	2800 FULLING MILL PO BOX 3608	HARRISBURG PA 17105
07416	NELSON NAME PLATE CO	3191 CASITAS	LOS ANGELES CA 90039-2410
2W733	BELDEN CORPORATION	2200 US HIGHWAY 27 SOUTH PO BOX 1980	RICHMOND IN 47375-0010
24931	SPECIALTY CONNECTOR CO INC	2100 EARLYWOOD DR PO BOX 547	FRANKLIN IN 46131
6D224	HARBOR TRI-TEC A BERG ELECTRONICS COMPANY	14500 SOUTH BROADWAY	GARDENA, CA 90248
61058	MATSUSHITA ELECTRIC CORP OF AMERICA PANASONIC INDUSTRIAL CO DIV	TWO PANASONIC WAY	SECAUCUS NJ 07094
61857	SAN-0 INDUSTRIAL CORP	91-3 COLIN DRIVE	HOLBROOK NY 11741
61935	SCHURTER INC	1016 CLEGG COURT	PETALUMA CA 94952-1152
64537	KDI/TRIANGLE ELECTRONICS	60 S JEFFERSON ROAD	WHIPPANY, NJ 07981
73743	FISCHER SPECIAL MFG CO	111 INDUSTRIAL RD	COLD SPRING KY 41076-9749
75915	LITTELFUSE TRACOR INC SUB OF TRACOR INC	800 E NORTHWEST HWY	DES PLAINES IL 60016-3049
78189	ILLINOIS TOOL WORKS INC SHAKEPROOF DIV	ST CHARLES ROAD	ELGIN IL 60120
80009	TEKTRONIX INC	14150 SW KARL BRAUN DR PO BOX 500	BEAVERTON OR 97077-0001
86928	SEASTROM MFG CO INC	701 SONORA AVE	GLENDALE CA 91201-2431
98291	SEAELECTRO CORP BICC ELECTRONICS	40 LINDEMAN DR	TURNBULL CT 06611-4739

Replaceable Mechanical Parts

Replaceable Parts List

Fig. & Index number	Tektronix part number	Serial no. effective	Serial no. dis-cont'd	Qty.	Name & description	Mfr. code	Mfr. part number
9-1					MAIN CHASSIS(1) (DTG5078)		
01-001	211-0871-00			16	SCREW,MACHINE, M3X6MM L,PNH,STL,ZN PL,CROSS REC,W/FLAT(7MM OD)& LOCK WASHER		
01-002	671-B230-50			1	CIRCUIT BD ASSY:A54 700MBPS MAIN BOARD,389-B232-XX WIRED		
01-003	174-C017-00			4	CABLE ASSY RF, 38,50OHM,150MM L,FLAT FLEX,YFLEX		
01-004	174-C057-00			2	CA ASSY,SP,ELEC, 34,30AWG,30CM L,W/CONN(YAMAICHI NFS)		
01-005	211-0751-00			6	SCREW,MACHINE, M3X8MM L,PNH,STL,ZN-C,CROSS REC W/FLAT&LOCK WASHERS		
01-006	407-A727-00			1	BRACKET,SUPPORT, CHASSIS,MAIN		
01-007	441-A313-02			1	CHASSIS,ASSY, PLUG-IN BOX		
01-008	174-C069-00			1	CA ASSY,RF, 50OHM,COAX,55CM L,1.5D-QEW,SMA(PANEL) TO SMB-STR		
01-009	407-A718-00			1	BRACKET,ANGLE, FRONT,SMA		
01-010	211-0751-00			2	SCREW,MACHINE, M3X8MM L,PNH,STL,ZN-C,CROSS REC W/FLAT&LOCK WASHERS		
01-011	348-A141-00			32	SHLD GSKT,ELEC, CONDUCTIVE URETHANE FORM,1 X 4 MM,W/ADHESIVE TAPE		
01-012	211-0751-00			2	SCREW,MACHINE, M3X8MM L,PNH,STL,ZN-C,CROSS REC W/FLAT&LOCK WASHERS		
01-013	131-1315-01			2	CONN,RF,JACK, BNC,50OHM,FEMALE,STR,PEL TORA,PANEL MOUNT		
01-014	407-A717-00			1	BRACKET,ANGLE, FRONT,BNC		
01-015	174-C062-00			1	CA ASSY,RF, 50OHM COAX,55CM L,PEL TORA TO PELTRA,MKD-2		
01-016	174-C061-00			1	CA ASSY,RF, 50OHM COAX,55CM L,PEL TORA TO PELTRA,MKD-1		
01-017	174-C073-00			1	CA ASSY,RF, 50OHM,COAX,55CM L,1.5D-QEW,SMA(PANEL) TO SMA-STR		
01-018	441-A300-02			1	CHASSIS,ASSY, MAIN, AL, DTG5000		
01-019	174-C071-00			1	CA ASSY,SP,ELEC, 4,26AWG,30CM L,FOR FAN MOTER		
01-020	348-0948-00			2	GROMMET,PLASTIC, NYLON,BLACK,RING,9.5MM ID		
01-022	212-A049-00			8	SCREW,MACHINE, M4X30MM L,BDGH,STL ZN-C PL,CROSS REC		
01-023	174-C066-00			2	CA ASSY,RF, 50OHM,COAX,25CM L,1.5D-QEW,SMA(PANEL) TO SMB-STR		
01-024	174-C067-00			8	CA ASSY,RF, 50OHM,COAX,30CM L,1.5D-QEW,SMA(PANEL) TO SMB-STR		
01-025	174-C068-00			1	CA ASSY,RF, 50OHM,COAX,45CM L,1.5D-QEW,SMA(PANEL) TO SMB-STR		
01-026	131-1315-01			7	CONN,RF,JACK, BNC,50OHM,FEMALE,STR,PEL TORA,PANEL MOUNT		
01-027	344-A019-00			2	CLIP,CABLE, WIRE SADDLE,16 MM X 15.5 MM,66 NYLON		
01-028	174-C059-00			4	CA ASSY,RF, 50OHM COAX,20CM L,PEL TORA TO PELTRA		

Replaceable Parts List (Cont.)

Fig. & Index number	Tektronix part number	Serial no. effective	Serial no. dis-cont'd	Qty.	Name & description	Mfr. code	Mfr. part number
01-029	174-C060-00			3	CA ASSY,RF, 50OHM COAX,30CM L,PELTORA TO PELTRA		
01-030	174-C056-00			2	CA ASSY,SP,ELEC, 18,18AWG,1-N,25CM L,MOLEX TO MOLEX		

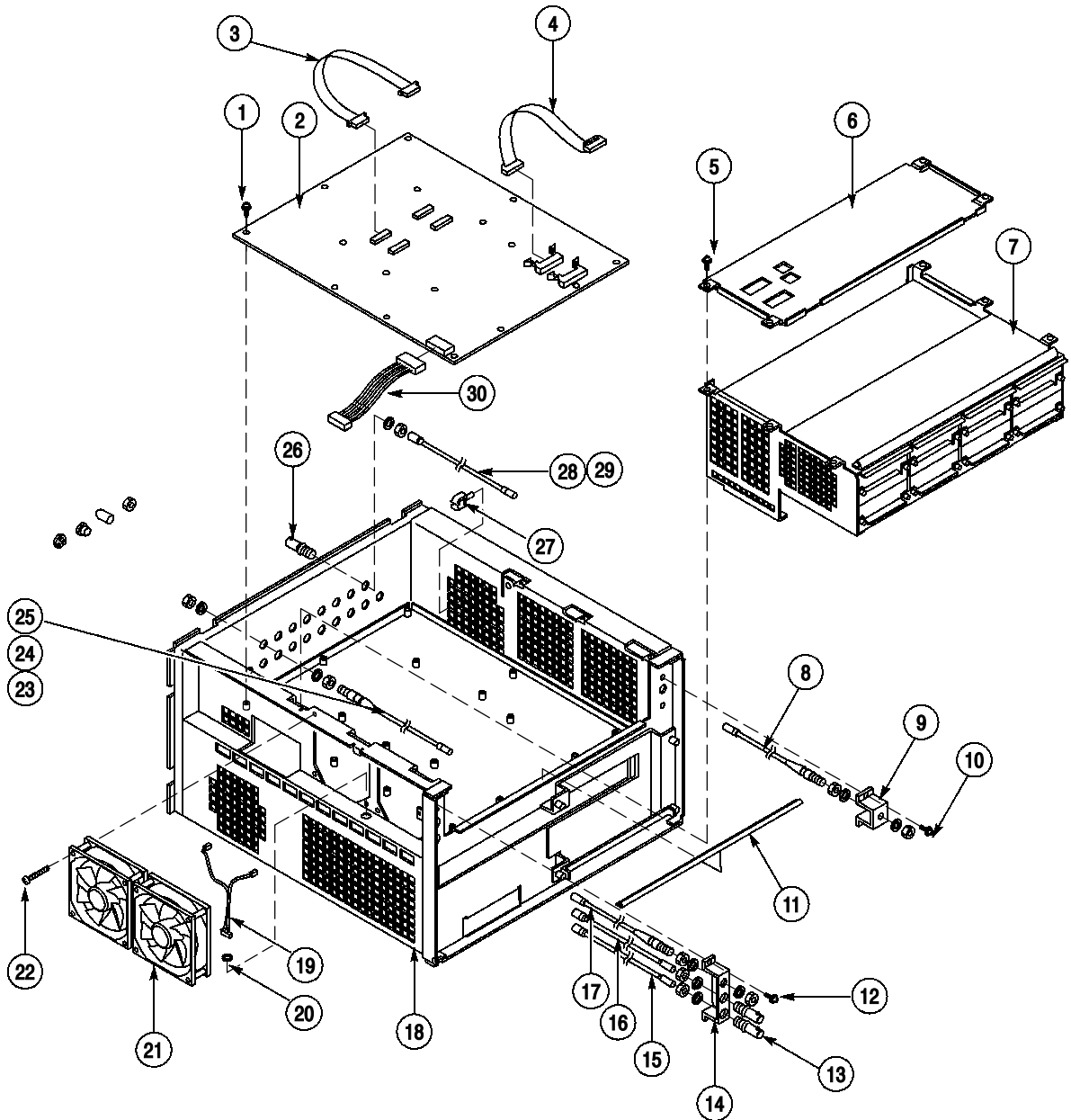

Figure 9-1: Main Chassis (1) (DTG5078)

Replaceable Mechanical Parts

Replaceable Parts List

Fig. & Index number	Tektronix part number	Serial no. effective	Serial no. dis-cont'd	Qty.	Name & description	Mfr. code	Mfr. part number
9-2					MAIN CHASSIS (1) DTG5274		
02-001	211-0871-00			16	SCREW,MACHINE, M3X6MM L,PNH,STL,ZN PL,CROSS REC,W/FLAT(7MM OD)& LOCK WASHER		
02-002	671-B229-50			1	CIRCUIT BD ASSY:A50 3.3GBPS MAIN BOARD,389-B231-XX WIRED		
02-003	174-C075-00			1	CA ASSY,RF, 38,50OHM,100MM L,FLAT FLEX,YFLEX		
02-004	174-C057-00			1	CA ASSY,SP,ELEC, 34,30AWG,30CM L,W/CONN(YAMAICHI NFS)		
02-005	211-0751-00			6	SCREW,MACHINE, M3X8MM L,PNH,STL,ZN-C,CROSS REC W/FLAT&LOCK WASHERS		
02-006	407-A727-00			1	BRACKET,SUPPORT, CHASSIS,MAIN		
02-007	441-A313-02			1	CHASSIS,ASSY, PLUG-IN BOX		
02-008	174-C069-00			1	CA ASSY,RF, 50OHM,COAX,55CM L,1.5D-QEW,SMA(PANEL) TO SMB-STR		
02-009	407-A718-00			1	BRACKET,ANGLE, FRONT,SMA		
02-010	211-0751-00			2	SCREW,MACHINE, M3X8MM L,PNH,STL,ZN-C,CROSS REC W/FLAT&LOCK WASHERS		
02-011	348-A141-00			32	SHLD GSKT,ELEC, CONDUCTIVE URETHANE FORM,1 X 4 MM,W/ADHESIVE TAPE		
02-012	211-0751-00			2	SCREW,MACHINE, M3X8MM L,PNH,STL,ZN-C,CROSS REC W/FLAT&LOCK WASHERS		
02-013	131-1315-01			2	CONN,RF,JACK, BNC,50OHM,FEMALE,STR,PEL TORA,PANEL MOUNT		
02-014	407-A717-00			1	BRACKET,ANGLE, FRONT,BNC		
02-015	174-C062-00			1	CA ASSY,RF, 50OHM COAX,55CM L,PELTORA TO PELTRA,MKD-2		
02-016	174-C061-00			1	CA ASSY,RF, 50OHM COAX,55CM L,PELTORA TO PELTRA,MKD-1		
02-017	174-C073-00			1	CA ASSY,RF, 50OHM,COAX,55CM L,1.5D-QEW,SMA(PANEL) TO SMA-STR		
02-018	441-A300-02			1	CHASSIS,ASSY, MAIN,AL,DTG5000		
02-019	174-C071-00			1	CA ASSY,SP,ELEC, 4,26AWG,30CM L,FOR FAN MOTER		
02-020	348-0948-00			2	GROMMET,PLASTIC, NYLON,BLACK,RING,9.5MM ID		
02-021	119-B103-00			2	FAN,TUBEAXIAL, 12V,225MA,2.7W ,2950RPM,56.8CFM,42.1P A,FBA09A12HZ		
02-022	212-A049-00			8	SCREW,MACHINE, M4X30MM L,BDGH,STL ZN-C PL,CROSS REC		
02-023	174-C063-00			2	CA ASSY,RF, 50OHM,COAX,20CM L,SMA(PANEL) TO U.FL		
02-024	174-C064-00			4	CA ASSY,RF, 50OHM,COAX,15CM L,SMA(PANEL) TO U.FL		
02-025	174-C065-00			3	CA ASSY,RF, 50OHM,COAX,25CM L,SMA(PANEL) TO U.FL		
02-026	134-0218-00			1	BUTTON PLUG		
02-027	134-A008-00			2	BUTTON,PLUG, NYLON66,BLACK		
02-028	131-1315-01			6	CONN,RF,JACK, BNC,50OHM,FEMALE,STR,PELTORA,PANEL MOUNT		
02-029	344-A019-00			2	CLIP,CABLE, WIRE SADDLE,16 MM X 15.5 MM,66 NYLON		
02-030	174-C059-00			3	CA ASSY,RF, 50OHM COAX,20CM L,PELTORA TO PELTRA		

Replaceable Parts List (Cont.)

Fig. & Index number	Tektronix part number	Serial no. effective	Serial no. dis-cont'd	Qty.	Name & description	Mfr. code	Mfr. part number
02-031	174-C060-00			3	CA ASSY,RF, 50OHM COAX,30CM L,PELTORA TO PELTRA		
02-032	174-C056-00			1	CA ASSY,SP,ELEC, 18,18AWG,1-N,25CM L,MOLEX TO MOLEX		

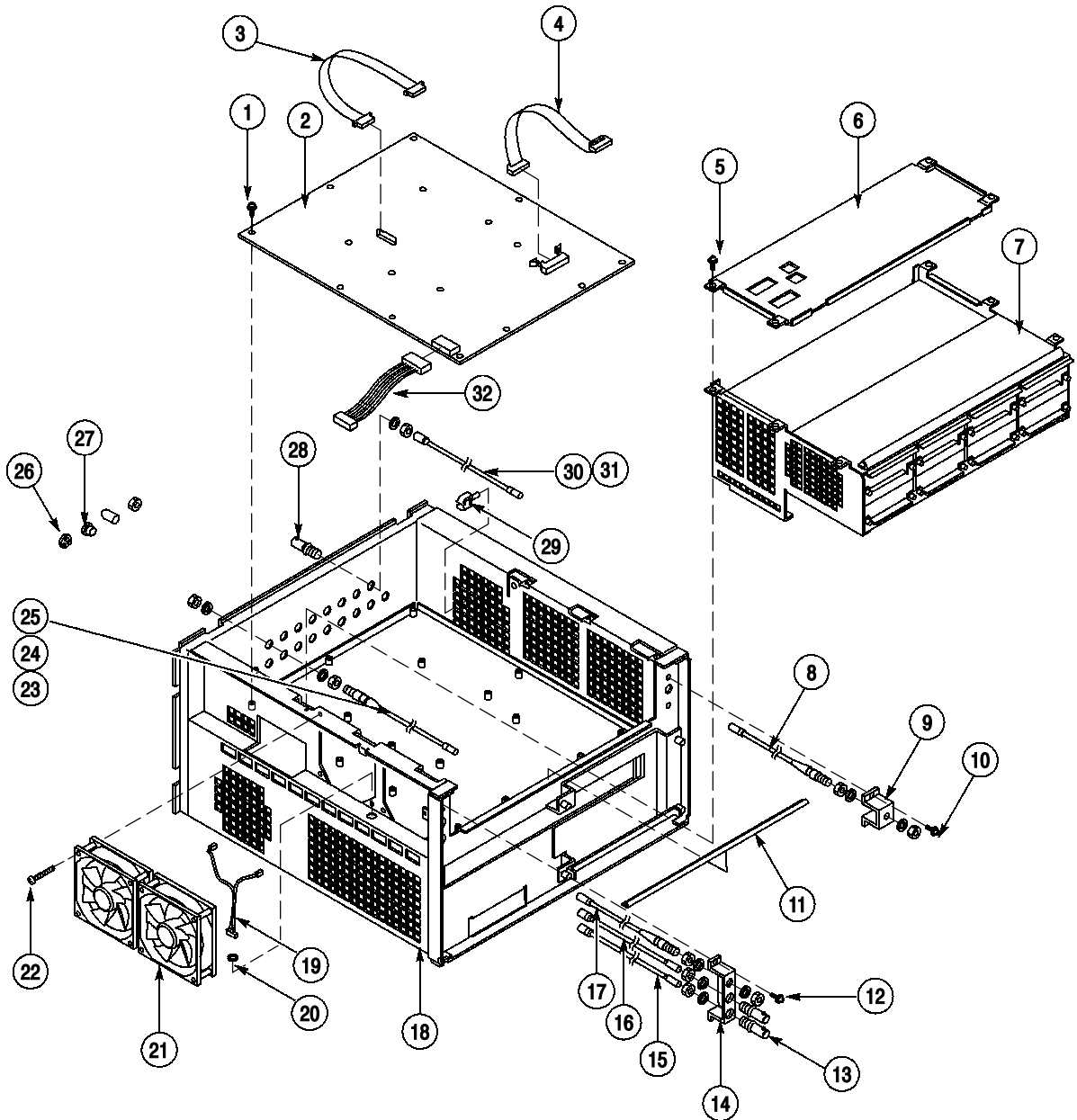

Figure 9-2: Main Chassis (1) (DTG5274)

Replaceable Mechanical Parts

Replaceable Parts List

Fig. & Index number	Tektronix part number	Serial no. effective	Serial no. dis-cont'd	Qty.	Name & description	Mfr. code	Mfr. part number
9-3					DTG5078 MAIN CHASSIS (2)		
03-001	212-A049-00			24	SCREW,MACHINE, M4X30MM L,BDGH,STL ZN-C PL,CROSS REC		
03-002	119-B103-00			6	FAN,TUBEAXIAL, 12V,225MA,2.7W,2950RPM,56.8CFM,42.1P A,FBA09A12HZ		
03-003	174-C070-00			1	CA ASSY,SP,ELEC, 12,26AWG,15CM L, FOR FAN MOTER		
03-004	211-0751-00			5	SCREW,MACHINE, M3X8MM L,PNH,STL,ZN-C,CROSS REC W/FLAT&LOCK WASHERS		
03-005	174-C072-00			1	CA ASSY,SP,ELEC, 3,26AWG,35CM L,W/CONN XH TO PH(JST)		
03-006	211-0751-00			2	SCREW,MACHINE, M3X8MM L,PNH,STL,ZN-C,CROSS REC W/FLAT&LOCK WASHERS		
03-007	174-C030-00			1	CA ASSY,SP,ELEC, 26 COND,250MM L,FLAT FLEX		
03-008	211-8800-50			1	SCREW,MACHINE, M4X8MM L,BDGH,STL,ZN-C		
03-009	210-0008-00			1	#8 INTL,0.02THK,CM1		
03-010	119-B191-00			1	GPIB INTERFACE CARD, COMPACT PCI,PXI-GPIB,/WINDOWS		
03-011	119-B190-00			1	CPU,UNIT, COMPACT PCI,CELERON 566MHz,128MB,815E,W/2.5IN HDD		
03-012	211-8800-50			1	SCREW,MACHINE, M4X8MM L,BDGH,STL,ZN-C		
03-013	211-0751-00			8	SCREW,MACHINE, M3X8MM L,PNH,STL,ZN-C,CROSS REC W/FLAT&LOCK WASHERS		
03-014	213-A249-00			4	SCREW,MACHINE, M4X20 L,PNH,STL,ZN-C,CROSS REC,W/FLAT(MIGAKI) & LOCK WASHER		
03-015	348-1648-00			4	FOOT, REAR		
03-016	333-A456-53			1	PANEL,REAR, AL,PRINTED		
03-017	260-2740-00			1	SWITCH,ROCKER, DPST,250VAC,10A W/I-O MKD		
03-018	211-1040-00			2	SCREW,MACHINE, M3X8MM L,FLH,STL,ZN-C,CROSS REC		
03-019	119-2683-00			1	FILTER,RFI, 6A,250VAC,50/60HZ		
03-020	174-4317-00			1	CA ASSY,SP,ELEC, 2,AWG18,12CM L,W/FASTON		
03-021	195-3990-00			1	LEAD,ELECTRICAL, AWG18,100MM L,5-4,W/LUG		
03-022	211-8800-50			1	SCREW,MACHINE, M4X8MM L,BDGH,STL,ZN-C		
03-023	210-0008-00			1	#8 INTL,0.02THK,CM1		
03-024	334-A630-01			1	MARKER,IDENT, MKD CONNECTOR NO.		
03-025	174-C055-00			1	CA ASSY,SP,ELEC, 18,18AWG,1-N,13CM L,MOLEX TO MOLEX		
03-026	671-B225-51			1	CIRCUIT BD ASSY:A10 CONNECTOR & PCI I/F BOARD,389-B227-XX WIRED		
03-027	211-0871-00			10	SCREW,MACHINE, M3X6MM L,PNH,STL,ZN PL,CROSS REC,W/FLAT(7MM OD)& LOCK WASHER		
03-028	174-C058-00			1	CA ASSY,SP,ELEC, 60,30AWG,20CM L,W/CONN(YAMAICHI NFS)		
03-029	211-0751-00			4	SCREW,MACHINE, M3X8MM L,PNH,STL,ZN-C,CROSS REC W/FLAT&LOCK WASHERS		

Replaceable Parts List (Cont.)

Fig. & Index number	Tektronix part number	Serial no. ef- fective	Serial no. dis- cont'd	Qty.	Name & description	Mfr. code	Mfr. part number
03-030	119-B125-00			1	DISPLY MONITOR, 8.4INCH,LCD,TFT,800X600,SVGA,3.3V ,W BACK LIGHT		
03-031	174-B983-00			1	CA ASSY,SP,ELEC, 30,30AWG,20CM,W/HLDR,W SHIELD,DF19-30S-1C CONN		
03-032	211-0751-00			4	SCREW,MACHINE, M3X8MM L,PNH,STL,ZN-C,CROSS REC W/FLAT&LOCK WASHERS		
03-033	174-B984-00			1	CA ASSY,SP,ELEC, 8,26AWG,13CM L,W/HLDR		
03-034	119-B126-00			1	INVERTER UNIT, COLD-CATHODE TUBE INVERTER FOR LTM08C351,12VDC,0.9A		
03-035	211-0871-00			2	SCREW,MACHINE, M3X6MM L,PNH,STL,ZN PL,CROSS REC,W/FLAT(7MM OD)& LOCK WASHER		
03-036	348-0948-00			6	GROMMET,PLASTIC, NYLON,BLACK,RING,9.5MM ID		
03-037	344-0472-00			2	BUSHING,NYLON,GRAY		
03-032	343-A322-00			6	CLAMP,CABLE, CLIP LOCKING WIRE,NYLON		

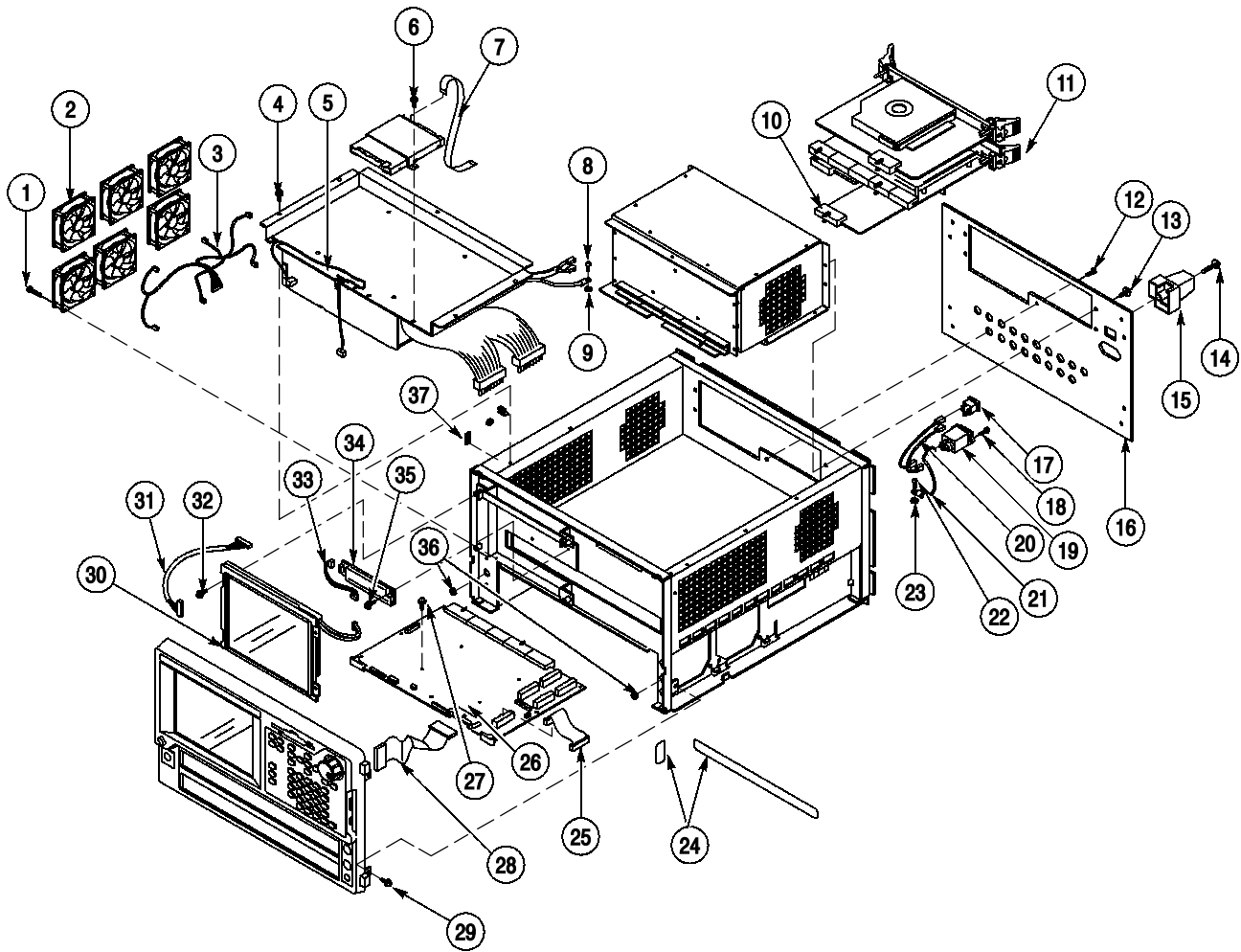

Figure 9-3: Main Chassis (2)

Replaceable Parts List

Fig. & index number	Tektronix part number	Serial no. effective	Serial no. dis-cont'd	Qty.	Name & description	Mfr. code	Mfr. part number
9-4					MAIN CHASSIS & CABINET		
04-001	348-A155-00			40	GASKET, SHIELD:CONDUCTIVE URETHAN FORM, 2MM x 4MM, W/CONDUCTIVE ADHESIVE		
04-002	062-A280-00			1	SOFTWARE LICENSE DRIVE IMAGE PROFESSIONAL LICENSE		
04-003	062-A278-00			1	SOFTWARE LICENSE EMD WINDOWS2000PROFFESIONAL EN,ENGLISH		
04-004	211-8800-50			4	SCREW,MACHINE, M4X8MM L,BDGH,STL,ZN-C		
04-005	211-8800-50			3	SCREW,MACHINE, M4X8MM L,BDGH,STL,ZN-C		
04-006	334-1378-50			1	MARKER,IDENT, MKD SERIAL NO. FOR TEK		

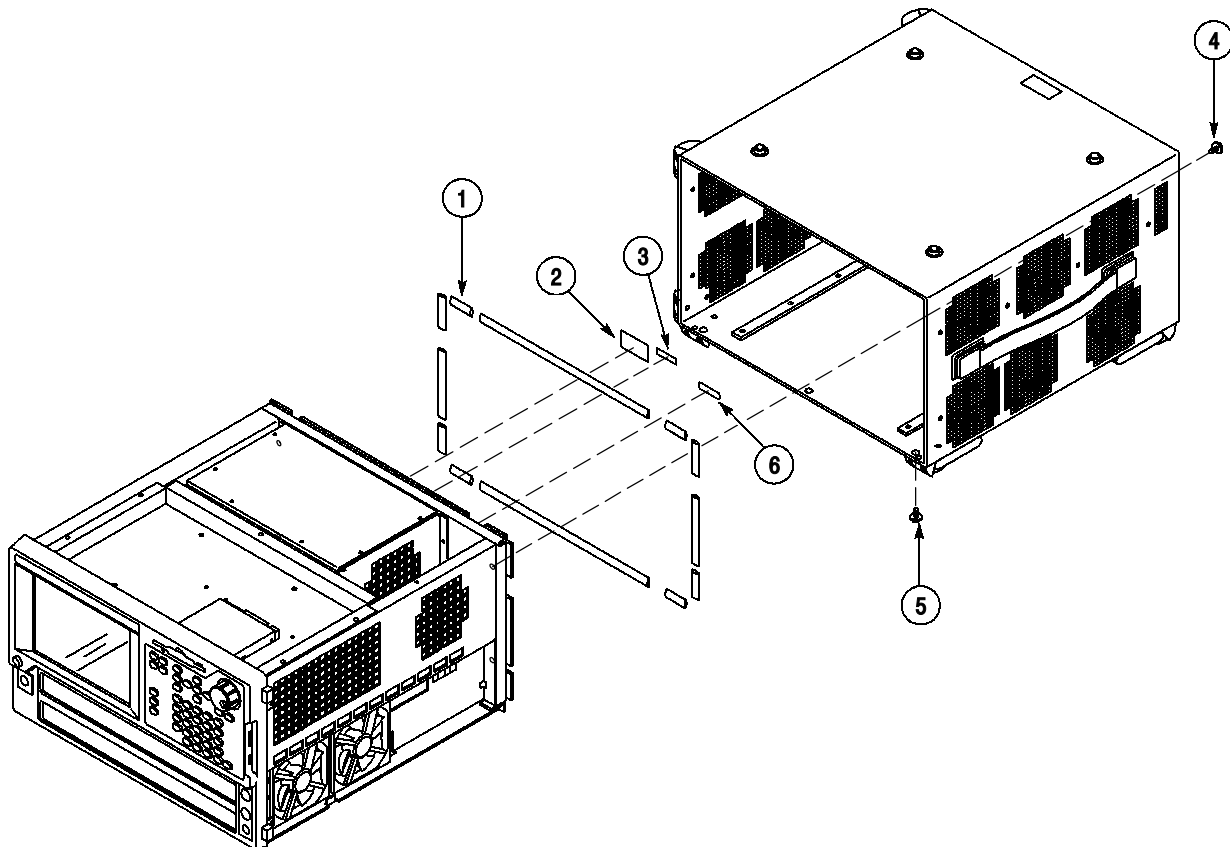

Figure 9-4: Main Chassis & Cabinet

Replaceable Mechanical Parts

Replaceable Parts List

Fig. & index number	Tektronix part number	Serial no. effective	Serial no. dis-cont'd	Qty.	Name & description	Mfr. code	Mfr. part number
9-5					A30 & COMPACT PCI FRAME		
05-001	671-B227-50				CIRCUIT BD ASSY:A30 COMPACT PCI BACK PLANE BOARD,389-B229-XX WIRED		
05-002	426-A200-01			1	FRAME,ASSY, COMPACT PCI,DTG5000		
05-003	348-1632-00			52	SHLD GASKET,ELEK, CONDUCTIVE URETHANE FOAM,9.5 MM SQ,W/ADHESIVE		
05-004	351-A173-00			3	GUIDE,CKT BD, BOTTOM,COMPACT PCI		
05-005	351-A174-00			3	GUIDE,CKT BD, TOP,COMPACT PCI		
05-006	211-0871-00			9	SCREW,MACHINE, M3X6MM L,PNH,STL,ZN PL,CROSS REC,W/FLAT(7MM OD)& LOCK WASHER		

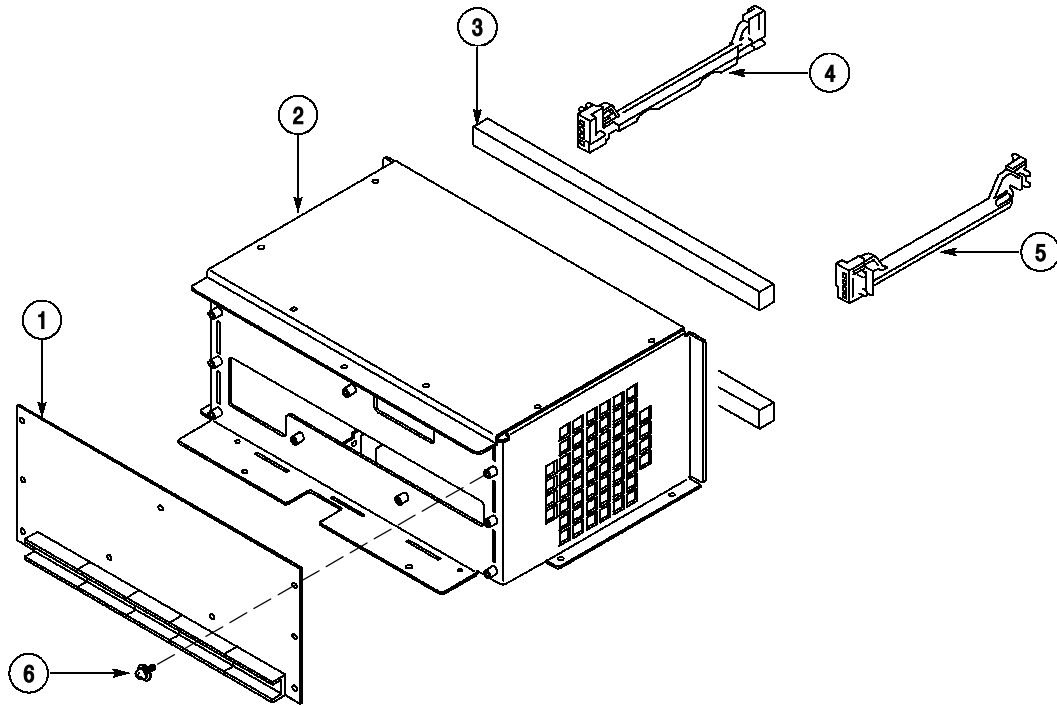

Figure 9-5: A30 & Compact PCI Frame

Replaceable Mechanical Parts

Replaceable Parts List

Fig. & index number	Tektronix part number	Serial no. effective	Serial no. dis-cont'd	Qty.	Name & description	Mfr. code	Mfr. part number
9-6					POWER SUPPLY		
06-001	344-0395-00			2	CLIP,CABLE, EDGE SADDLE,GRAY,20MM X 10.0MM,66-NYLON,ACCOM 1.6 to 1.0MM THK		
06-002	211-8800-50			4	SCREW,MACHINE, M4X8MM L,BDGH,STL,ZN-C		
06-003	407-A712-01			1	BRACKET,POWER SUPPLY, AL,T1.6		
06-004	174-C053-00			1	CA ASSY,SP,ELEC, 3,18AWG,15CM Lx1 LUG TO LUG,25 CMx2 LUG M4 TO FSTN W/TUBE		
06-005	174-C054-00			2	CA ASSY,SP,ELEC, 18,18AWG,25CM L,MOLEX TO LUG M4		
06-006	119-B189-00			1	POWER SUPPLY		

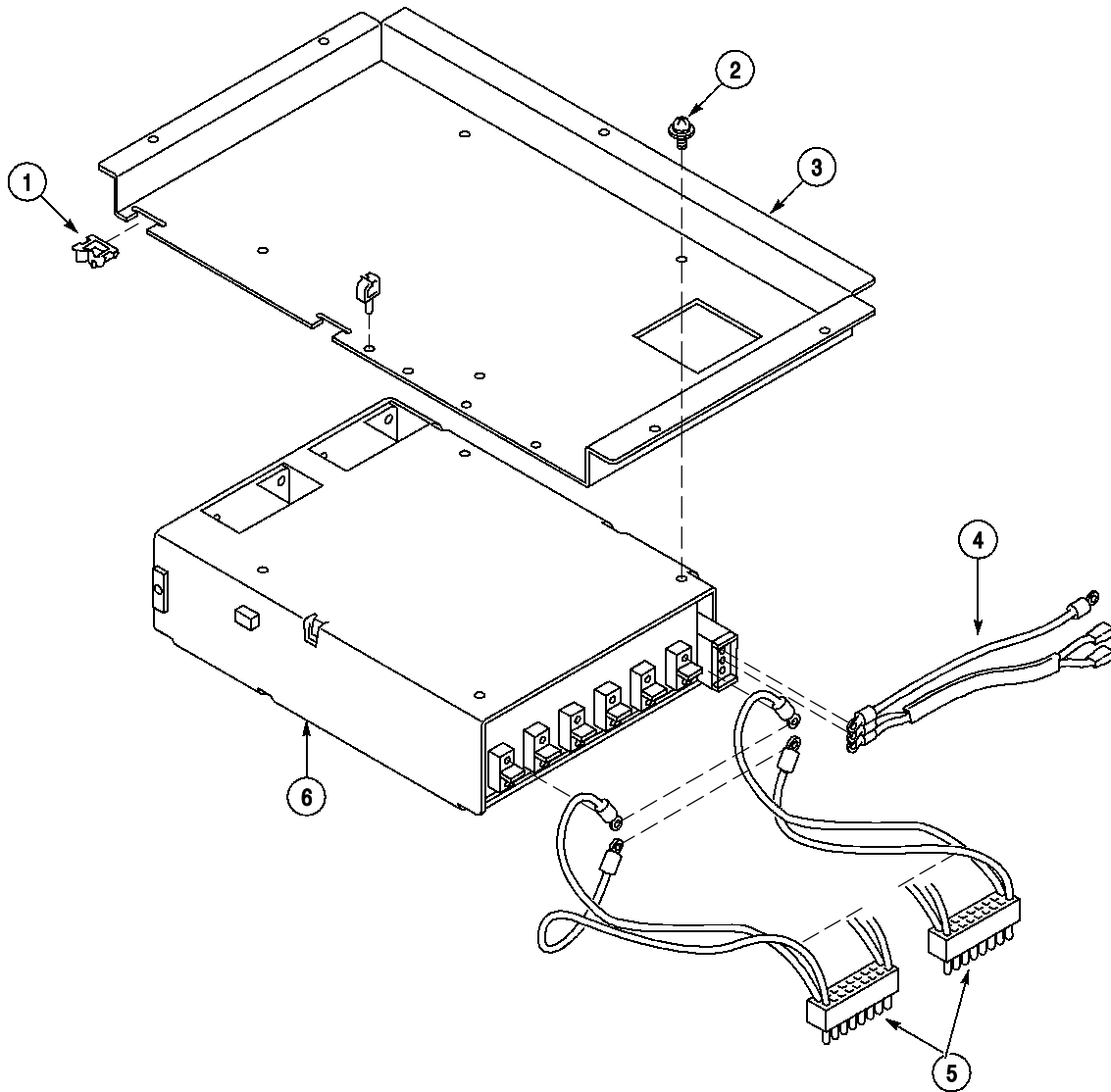

Figure 9-6: Power Supply

Replaceable Parts List

Fig. & index number	Tektronix part number	Serial no. effective	Serial no. dis-cont'd	Qty.	Name & description	Mfr. code	Mfr. part number
9-7					FLOPPY DISK DRIVE UNIT		
07-001	119-5953-00			1	FLOPPY DISK DRIVE, 3.5 INCH 3-MODE W/INTERFACE		
07-002	407-A716-01			1	BRACKET,FDD, AL,T1.6		
07-003	211-A275-00			2	SCREW,MACHINE, M2.6X5MM L,PNH,STL,ZN-C,CROSS REC,W/K-PLAIN & LOCK WASH		

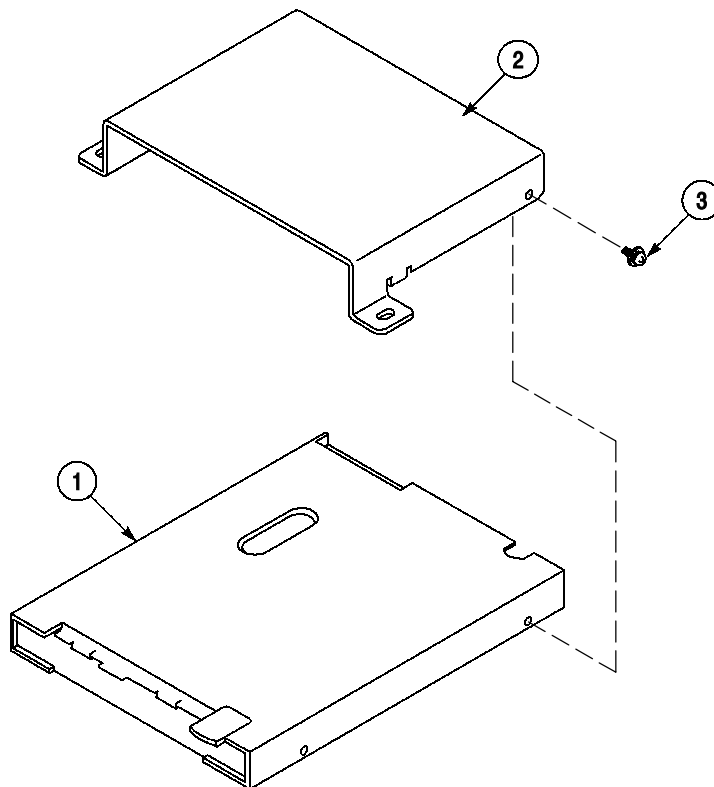

Figure 9-7: Floppy Disk Drive

Replaceable Parts List

Fig. & index number	Tektronix part number	Serial no. effective	Serial no. dis-cont'd	Qty.	Name & description	Mfr. code	Mfr. part number
9-8					A10 CONNECTOR & PCI Interface		
08-001	105-A068-00			2	EJECTOR,BD,CBE-15		
08-002	671-B225-51			1	CIRCUIT BD ASSY:A10 CONNECTOR & PCI I/F BOARD,389-B227-XX WIRED		

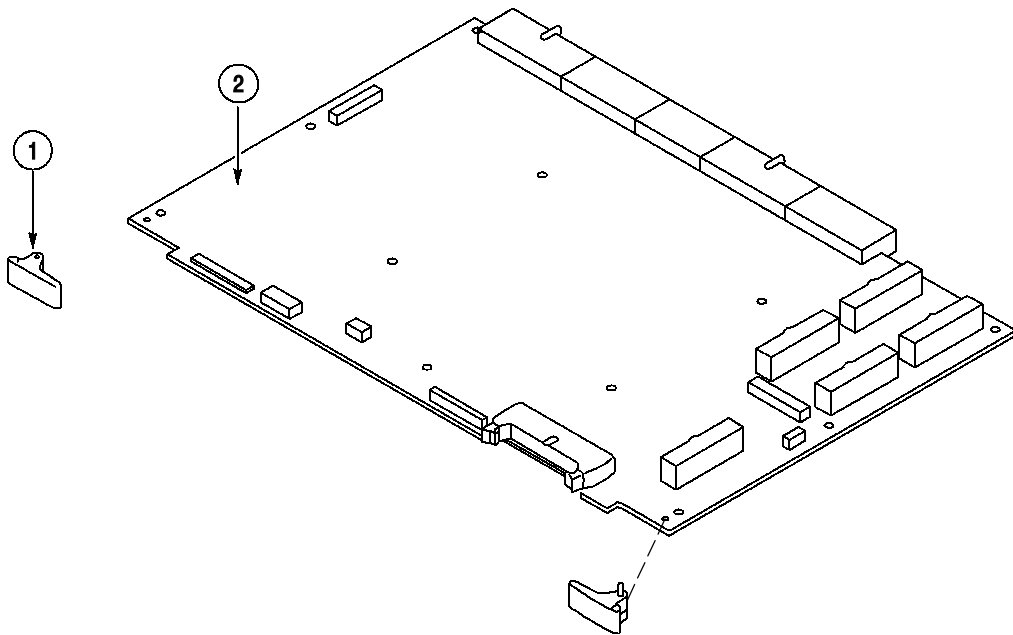

Figure 9-8: A10 Connector & PCI Interface

Replaceable Mechanical Parts

Replaceable Parts List

Fig. & index number	Tektronix part number	Serial no. effective	Serial no. dis-cont'd	Qty.	Name & description	Mfr. code	Mfr. part number
9-9					A32 CDROM Extender		
09-001	333-A457-00			1	PANEL,ASSY, CPCI,CD-ROM UNIT		
09-002	671-B228-50			1	CIRCUIT BD ASSY:A32 CD ROM EXTENDER BOARD,389-B230-XX WIRED		
09-003	407-A737-00				BRACKET,CD-ROM, LEFT,STL,T1.6,DTG5000		
09-004	259-A004-00			1	FLEX CIRCUIT, A34 CD_ROM CONNECT		
09-005	119-B199-00			1	CD-ROM DRIVE UNIT, 12/8CM,CD/CD-ROM,X24		
09-006	407-A736-00			1	BRACKET,CD-ROM, RIGHT,STL,T1.6,DTG5000		
09-007	211-A269-00			4	SCREW,MACHINE, M2X4MM L,PNH,STL ZN-C,CROSS REC,W/FLAT(6MM OD) WASHER		
09-008	211-0905-00			4	SCREW,MACHINE, M3X6MM L,PNH,STL ZN-C,CROSS REC		

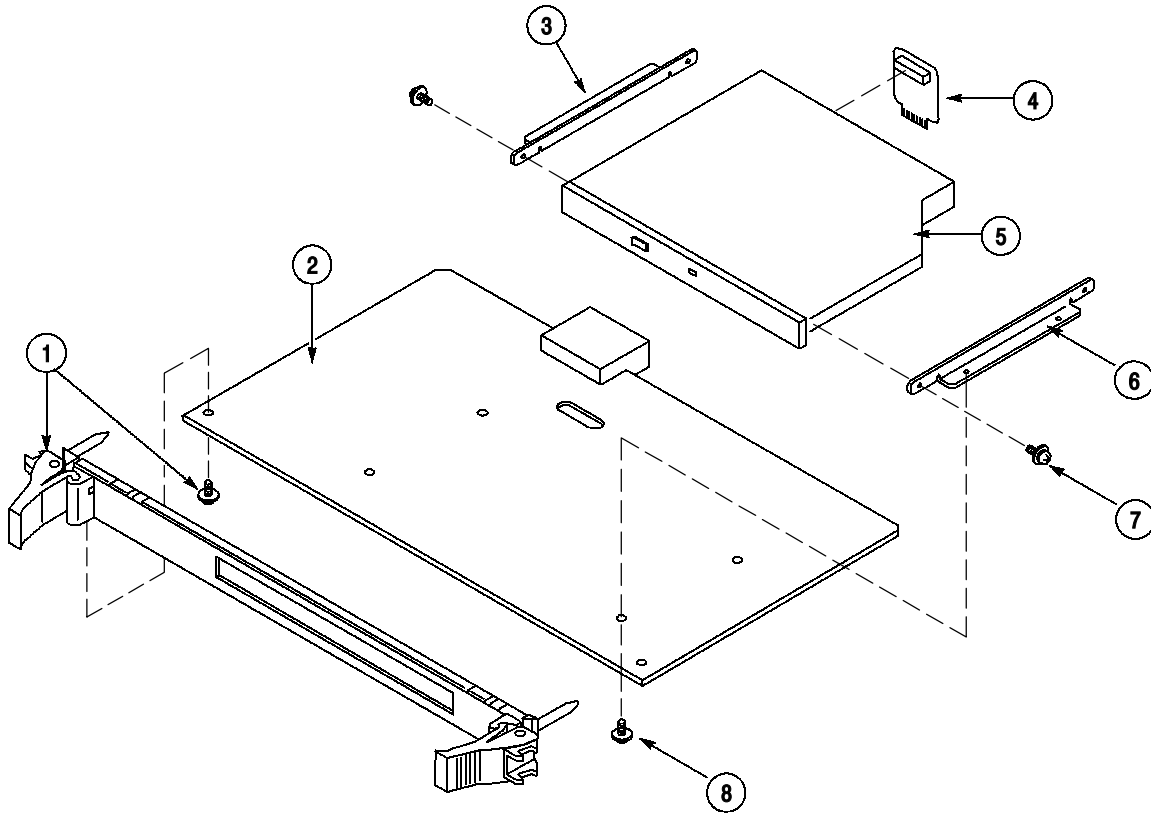

Figure 9-9: A32 CDROM Extender

Replaceable Parts List

Fig. & index number	Tektronix part number	Serial no. effective	Serial no. dis-cont'd	Qty.	Name & description	Mfr. code	Mfr. part number
9-10					FRONT PANEL (DTG5078)		
10-001	334-A612-00			1	MAKER,IDENT, SKEW-CAL,DTG7000 (LEXAN Film)		
10-002	334-A617-52			1	MARKER,IDENT:MKD,DTG5078		
10-003	200-A534-00			1	BEZEL,FRONT:DTG5000		
10-004	348-A141-00			63	SHLD GSKT,ELEC, CONDUCTIVE URETHANE FORM,1 X 4 MM,W/ADHESIVE TAPE		
10-005	378-A050-00			1	FILTER,LCD, ACRYL,WCA200,191.6MM X 149.5MM X 1.2MM T		
10-006	671-B262-50			1	CIRCUIT BD ASSY:A22,POWER SW BOARD,389-B254-00 WIRED		
10-007	213-1127-00			17	SCREW,TPG, M3X8MM L,PNH,STL,BLK ZN PL,CROSS REC		
10-008	174-B832-00			1	CA ASSY,SP,ELEC, 4,26AWG,W/CONN BOTH END,30CM L,W53		
10-009	343-A318-00			2	STRAP,TIEDOWN, BLACK NYLON		
10-010	441-A311-02			1	CHASSIS,ASSY, FRAME FRONT		
10-011	348-A159-00			15	GASKET,SHIELD, FINGER TYPE,BE-CU,8.13MM W X 2.79MM H X 406.4MM L		
10-012	348-A128-00			41	SHLD GASKET,ELEK, FINGER TYPE,5.1MM L X 6.4MM W,BE-CU		
10-013	348-A155-00			68	GASKET,SHIELD, CONDUCTIVE URETHAN FORM,2MM X 4MM,W/CONDUCTIVE ADHESIVE		
10-014	671-B226-50			1	CIRCUIT BD ASSY:A20 FRONT KEY & DC OUTPUT BOARD,389-B228-XX WIRED		
10-015	366-A060-01			1	RUBBER,SET, SILICON,DTG5000		
10-016	260-A156-00			1	SWITCH,ROTARY, ENCODER,5VDC,70MA INCREMENTAL,260-A153-00 W/CONN		
10-017	334-A613-01			1	MARKER,IDENT:OUTPUT,DTG5000		
10-018	334-A610-01			1	MARKER,IDENT:A-C-E-G		
10-019	334-A611-01			1	MARKER,IDENT:B-D-F-H		
10-020	334-A609-00			1	MAKER,IDENT, KEYBOARD,DTG5000 (LEXAN Film)		
10-021	366-A058-00			1	SHELL,KNOB, SILVER GRAY,38MMODx12MMH		

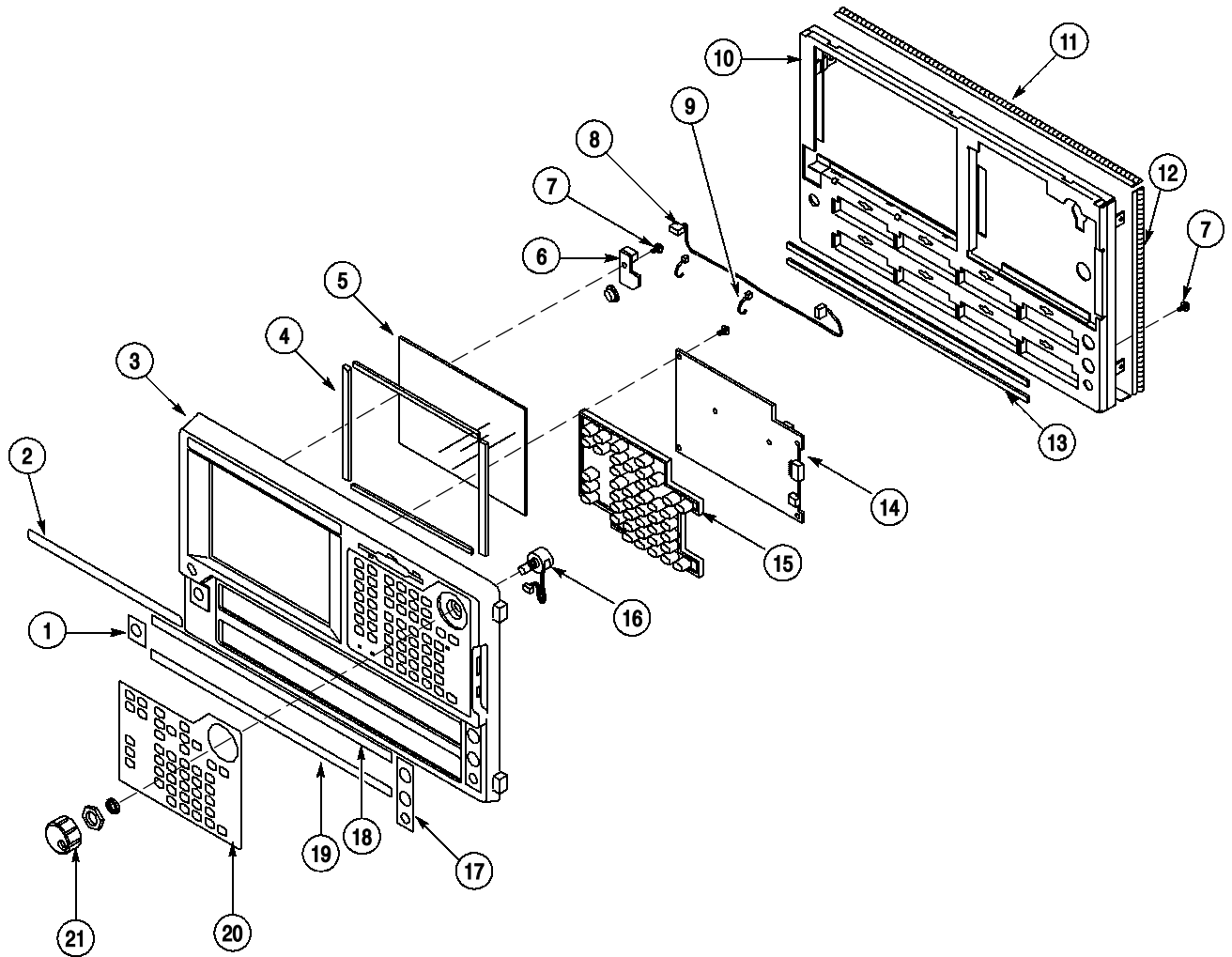

Figure 9-10: Front Panel (DTG5078)

Replaceable Parts List

Fig. & Index number	Tektronix part number	Serial no. effective	Serial no. dis-cont'd	Qty.	Name & description	Mfr. code	Mfr. part number
9-11					FRONT PANEL (DTG5274)		
11-001	334-A612-00			1	MAKER,IDENT, SKEW-CAL,DTG7000 (LEXAN Film)		
11-002	334-A618-52			1	MARKER,IDENT:MKD,DTG5274		
11-003	200-A534-00			1	BEZEL,FRONT:DTG5000		
11-004	348-A141-00			63	SHLD GSKT,ELEC, CONDUCTIVE URETHANE FORM,1 X 4 MM,W/ADHESIVE TAPE		
11-005	378-A050-00			1	FILTER,LCD, ACRYL,WCA200,191.6MM X 149.5MM X 1.2MM T		
11-006	671-B262-50			1	CIRCUIT BD ASSY:A22,POWER SW BOARD,389-B254-00 WIRED		
11-007	213-1127-00			17	SCREW,TPG, M3X8MM L,PNH,STL,BLK ZN PL,CROSS REC		
11-008	174-B832-00			1	*CA ASSY,SP,ELEC, 4,26AWG,W/CONN BOTH END,30CM L,W53		
11-009	343-A318-00			2	STRAP,TIEDOWN, BLACK NYLON		
11-010	441-A311-02			1	CHASSIS,ASSY, FRAME FRONT		
11-011	348-A159-00			15	GASKET,SHIELD, FINGER TYPE,BE-CU,8.13MM W X 2.79MM H X 406.4MM L		
11-012	348-A128-00			41	SHLD GASKET,ELEK, FINGER TYPE,5.1MM L X 6.4MM W,BE-CU		
11-013	348-A155-00			68	GASKET,SHIELD, CONDUCTIVE URETHAN FORM,2MM X 4MM,W/CONDUCTIVE ADHESIVE		
11-014	671-B226-50			1	CIRCUIT BD ASSY:A20 FRONT KEY & DC OUTPUT BOARD,389-B228-XX WIRED		
11-015	366-A060-01			1	RUBBER,SET, SILICON,DTG5000		
11-016	260-A156-00			1	SWITCH,ROTARY, ENCODER,5VDC,70MA INCREMENTAL,260-A153-00 W/CONN		
11-017	211-0871-00			2	SCREW,MACHINE, M3X6MM L,PNH,STL,ZN PL,CROSS REC,W/FLAT(7MM OD)& LOCK WASHER		
11-018	407-A728-00			2	BRACKET, BKANKPANEL,DTG5274,AL		
11-019	348-A141-00			66	SHLD GSKT,ELEC, CONDUCTIVE URETHANE FORM,1 X 4 MM,W/ADHESIVE TAPE		
11-020	386-A876-00			1	SUBPANEL,FRONT, BLANK,DTG5274,AL		
11-021	333-A461-00			2	PANEL,FRONT, BLANK,DTG5274,POL YCARBONATE		
11-022	334-A613-01			1	MARKER,IDENT:OUTPUT,DTG5000		
11-023	334-A619-01			1	*MARKER,IDENT:A-B-C-D		
11-024	334-A620-00			1	MAKER,IDENT, BLANK,DTG5000,LEXAN FILM		
11-025	334-A609-00			1	MAKER,IDENT, KEYBOARD,DTG5000 (LEXAN Film)		
11-026	366-A058-00			1	SHELL,KNOB, SILVER GRAY,38MMODx12MMH		

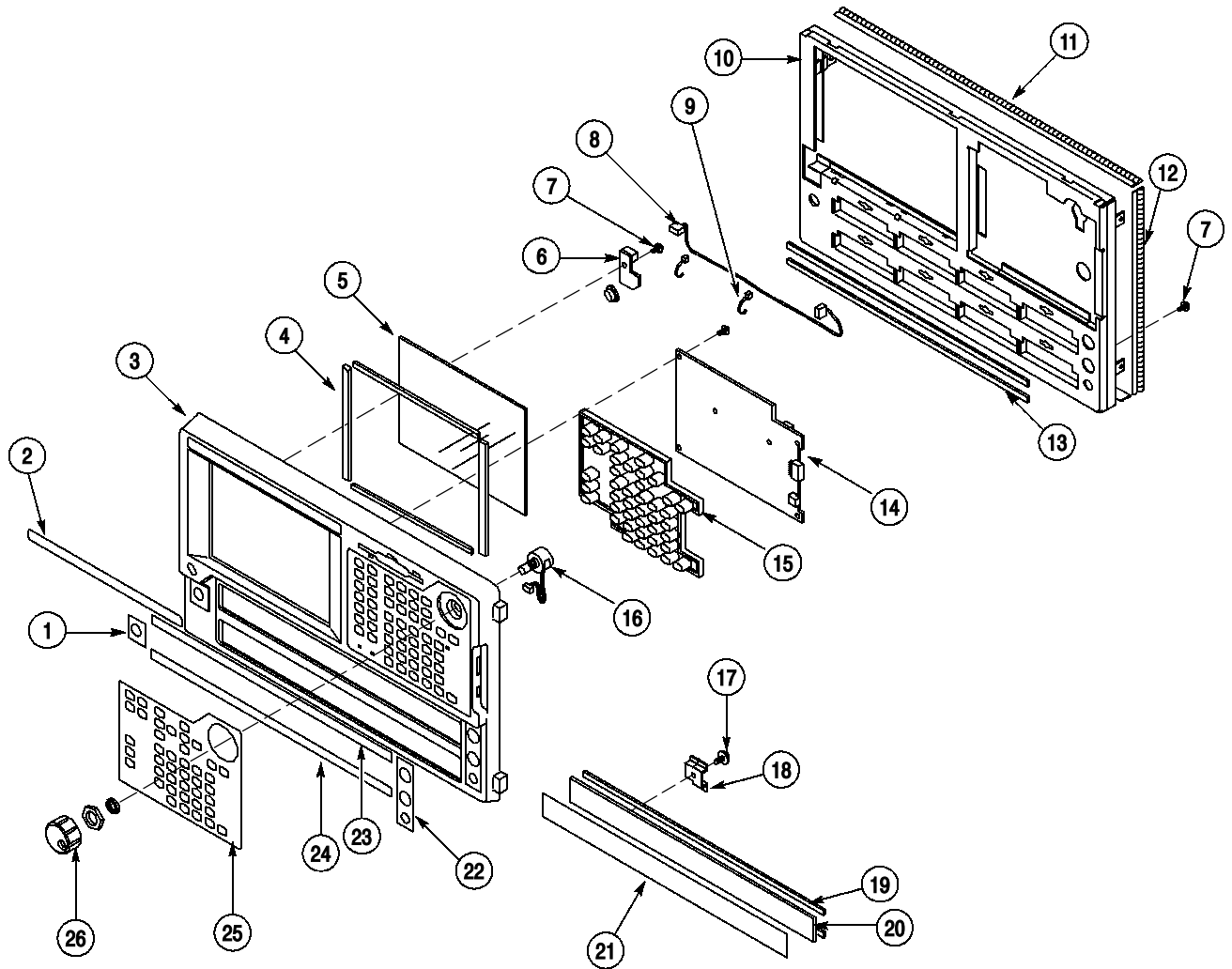

Figure 9-11: Front Panel (DTG5274)

Replaceable Mechanical Parts

Replaceable Parts List

Fig. & index number	Tektronix part number	Serial no. effective	Serial no. dis-cont'd	Qty.	Name & description	Mfr. code	Mfr. part number
9-12					CABINET		
12-001	214-B287-00				FASTENER, POP RIVET,FLAT HEAD,METAL,T1.0 TO T3.2"		
12-002	348-A154-00			4	FOOT PAD, CABINET FEET,BLACK,GLASS-FIBRE REINFORCED PLASTIC		
12-003	214-B282-01			4	FASTENER,BAG		
12-004	390-1216-00			1	CABINET: DTG5000		
12-005	200-2191-00			2	CAP,RETAINER		
12-006	367-0247-01			1	HANDLE CARRYING		
12-007	348-1515-00			1	FOOT:ELMA 63-526		
	348-A141-00			30	SHLD GSKT,ELEC, CONDUCTIVE URETHANE FORM,1 X 4 MM,W/ADHESIVE TAPE		

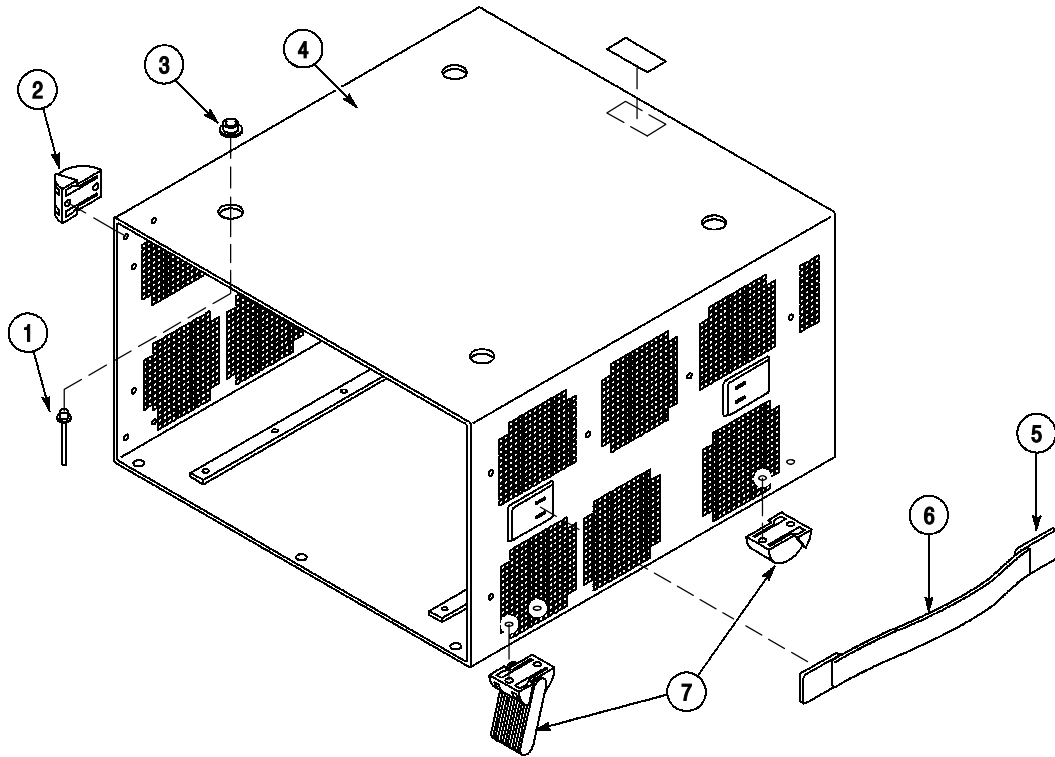

Figure 9-12: Cabinet

Replaceable Mechanical Parts

Replaceable Parts List

Fig. & index number	Tektronix part number	Serial no. effective	Serial no. dis-cont'd	Qty.	Name & description	Mfr. code	Mfr. part number
9-13					PLUG-IN BOX (DTG5078)		
13-001	441-A313-02			1	CHASSIS,ASSY, PLUG-IN BOX		
13-002	348-A141-00			16	SHLD GSKT,ELEC, CONDUCTIVE URETHANE FORM,1 X 4 MM,W/ADHESIVE TAPE		
13-003	211-0871-00			9	SCREW,MACHINE, M3X6MM L,PNH,STL,ZN PL,CROSS REC,W/FLAT(7MM OD)& LOCK WASHER		
13-004	342-A165-00			4	INSULATOR,PLATE, HEAT CONDUCTOR,A60/62,30MM SQ,T=2MM		
13-005	214-B276-00			2	HEAT SINK,ASSY, A62,FRONT		
13-006	211-0871-00			8	SCREW,MACHINE, M3X6MM L,PNH,STL,ZN PL,CROSS REC,W/FLAT(7MM OD)& LOCK WASHER		
13-007	671-B232-51			1	CIRCUIT BD ASSY:A62 700MBPS OUTPUT BOARD,389-B234-XX WIRED		
13-008	211-A171-00			4	SCREW,MACHINE, M3X12MM L,PNH,STL,ZN-CM1,W/K-PLAIN & SPLIT WASHER		
13-009	351-A172-00			8	GUIDE,CKT BD, MICTOR CONNECTOR,AL		
13-010	211-0871-00			9	SCREW,MACHINE, M3X6MM L,PNH,STL,ZN PL,CROSS REC,W/FLAT(7MM OD)& LOCK WASHER		
13-011	342-A165-00			4	INSULATOR,PLATE, HEAT CONDUCTOR,A60/62,30MM SQ,T=2MM		
13-012	214-B276-00			2	HEAT SINK,ASSY, A62,FRONT		
13-013	211-0871-00			8	SCREW,MACHINE, M3X6MM L,PNH,STL,ZN PL,CROSS REC,W/FLAT(7MM OD)& LOCK WASHER		
13-014	671-B278-50			1	CIRCUIT BD ASSY:A63 OUTPUT,389-B234-51 WIRED		
13-015	351-A172-00			8	GUIDE,CKT BD, MICTOR CONNECTOR,AL		
13-016	211-A171-00			4	SCREW,MACHINE, M3X12MM L,PNH,STL,ZN-CM1,W/K-PLAIN & SPLIT WASHER		
13-017	348-1472-00			33	SHIELD GASKET		

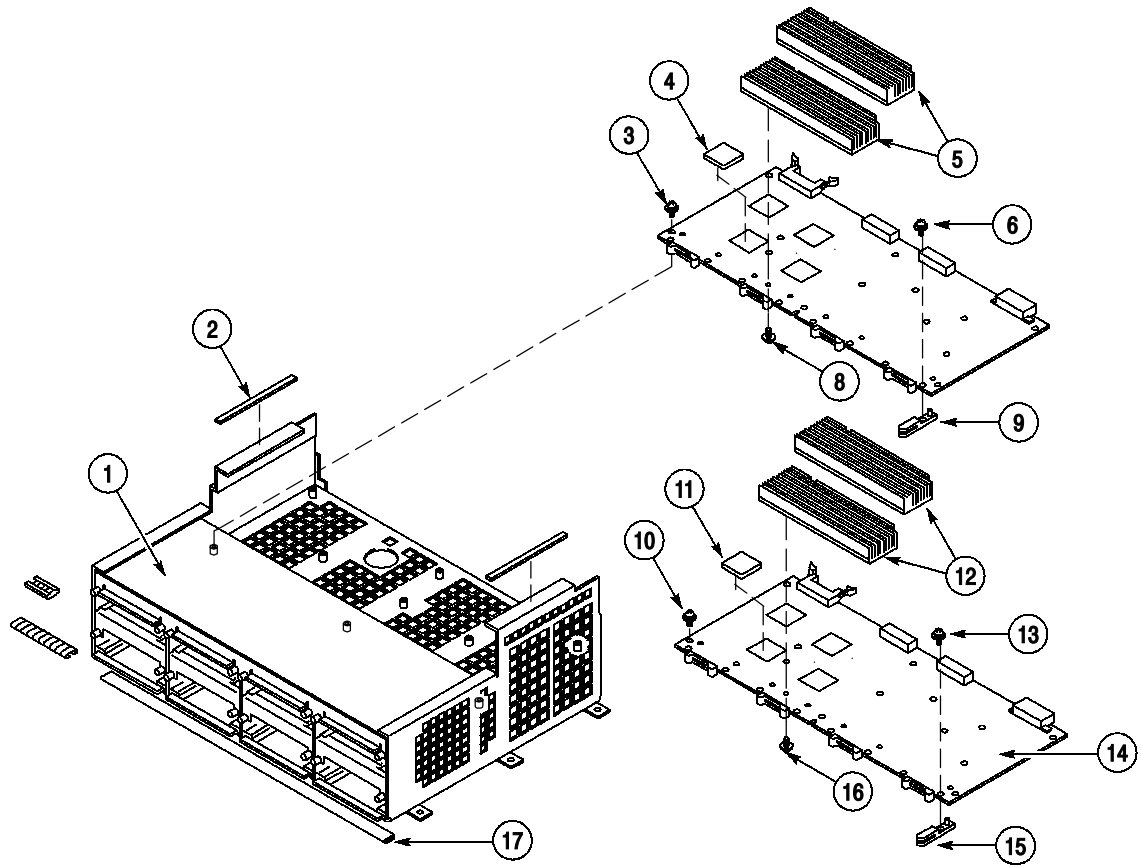

Figure 9-13: Plug-In Box (DTG5078)

Replaceable Mechanical Parts

Replaceable Parts List

Fig. & index number	Tektronix part number	Serial no. effective	Serial no. dis-cont'd	Qty.	Name & description	Mfr. code	Mfr. part number
9-14					PLUG-IN BOX (DTG5274)		
14-001	441-A313-02			1	CHASSIS,ASSY, PLUG-IN BOX		
14-002	348-A141-00			16	SHLD GSKT,ELEC, CONDUCTIVE URETHANE FORM,1 X 4 MM,W/ADHESIVE TAPE"		
14-003	211-0871-00			9	SCREW,MACHINE, M3X6MM L,PNH,STL,ZN PL,CROSS REC,W/FLAT(7MM OD)& LOCK WASHER		
14-004	671-B231-51			1	CIRCUIT BD ASSY:A60 3.3G/1.65GBPS OUTPUT BOARD,389-B233-XX WIRED		
14-005	214-B275-00			1	HEAT SINK,ASSY, A60,REAR		
14-006	214-B274-00			1	HEAT SINK,ASSY, A60,FRONT		
14-007	211-0871-00			8	SCREW,MACHINE, M3X6MM L,PNH,STL,ZN PL,CROSS REC,W/FLAT(7MM OD)& LOCK WASHER		
14-008	342-A165-00			4	INSULATOR,PLATE, HEAT CONDUCTOR,A60/62,30MM SQ,T=2MM		
14-009	351-A172-00			8	GUIDE,CKT BD, MICTOR CONNECTOR,AL		
14-010	211-A171-00			4	SCREW,MACHINE, M3X12MM L,PNH,STL,ZN-CM1,W/K-PLAIN & SPLIT WASHER		
14-011	348-1472-00			33	SHIELD GASKET		

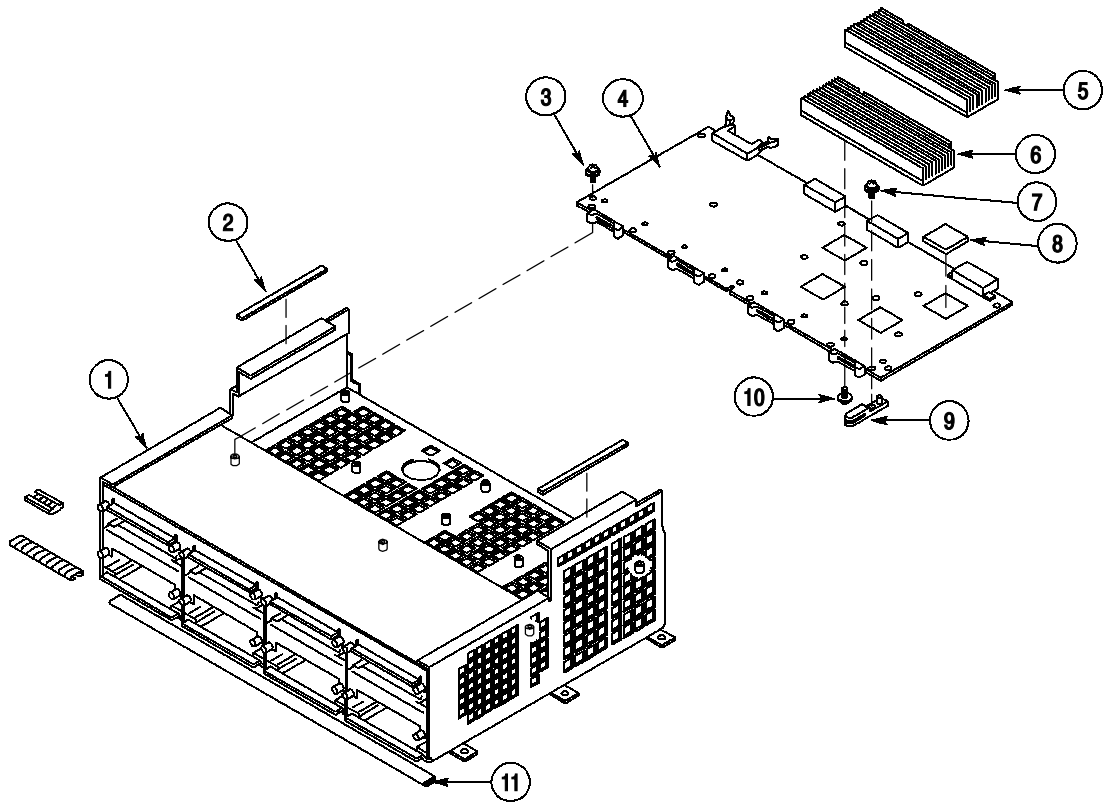

Figure 9-14: Plug-In Box (DTG5274)

Replaceable Mechanical Parts

Replaceable Parts List

Fig. & index number	Tektronix part number	Serial no. effective	Serial no. dis-cont'd	Qty.	Name & description	Mfr. code	Mfr. part number
9-15					DTG5078 FBLANK PLUG-IN		
15-001	333-A462-00			8	PANEL,FRONT, BLANK PLUG-IN,POLYCARBONATE		
15-002	214-B284-00			16	FASTENER ASSY, M2.5 SCREW,PRESSMOUNT,SPRING-LOADED		
15-003	348-A155-00			40	GASKET,SHIELD, CONDUCTIVE URETHAN FORM,2MM X 4MM,W/CONDUCTIVE ADHESIVE		
15-004	441-A316-01			8	CHASSIS,ASSY, BLANK PLUG-IN		

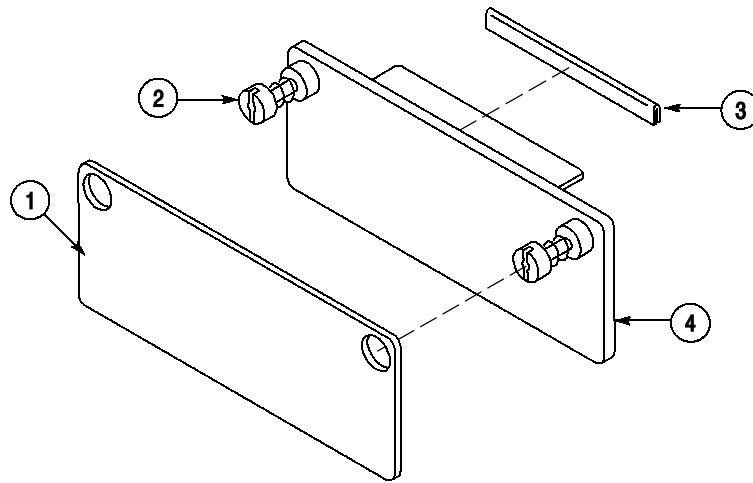

Figure 9-15: Blank Plug-In

Replaceable Mechanical Parts

Replaceable Parts List

Fig. & index number	Tektronix part number	Serial no. effective	Serial no. dis-cont'd	Qty.	Name & description	Mfr. code	Mfr. part number
9-16					DTGM10		
	671-B258-51				A74		
16-001	333-A458-01			1	PANEL, FRONT:DTGM10, POLYCARBONATE		
16-002	211-1039-00			2	SCREW, MACHINE:M2.5X6MM L, FLH, STL, CR PL, CROSS REC		
16-003	386-A873-00			1	SUBPANEL, FRONT:PLUG-IN		
16-004	348-A155-00			5	GASKET, SHIELD:CONDUCTIVE URETHAN FORM, 2MM X 4MM, W/CONDUCTIVE ADHESIVE		
16-005	259-A005-01			1	FLEX CIRCUIT:A80 ON/OFF LED, W/LED		
16-006	214-B284-00			1	FASTNER ASSY:M2.5 SCREW, PRESSMOUNT, SPRING-LOADED		
16-007	348-A156-00			10	GASKET, SHIELD:FINGER TYPE, BE-CU, 8.13MM W X 2.79MM H X 406.4MM L		
16-008	348-A157-00			1	GASKET, SHIELD:CONDUCTIVE SHEET, FOR DTG PLUG-IN		
16-009	211-A151-00			8	SCREW, MACHINE:M2.5X6MM L, PNH, STL, ZN-C, CROSS REC, W/KOGATA-PLAIN & SPLIT WSHR		
16-010	342-A167-00			2	INSULATOR, PLATE:HEAT CONDUCTOR, A74, 15MM SQ, T=0.5MM		
16-011	214-B280-01			1	HEAT SINK:A74 BD		
16-012	211-A242-00			4	SCREW, MACHINE:M3X12MM L, STL, BLK, W/K-PLAIN & SPLIT, KOGATAMARU		
16-013	211-0871-00			1	SCREW, MACHINE:M3X6MM L, PNH, STL, ZN PL, CROSS REC, W/FLAT(7MM OD)& LOCK WASHER		
16-014	671-B258-51			1	CIRCUIT BD ASSY:A74 DTGM20(EDGE693), 389-B245-xx WIRED		
16-015	211-0871-00			2	SCREW, MACHINE:M3X6MM L, PNH, STL, ZN PL, CROSS REC, W/FLAT(7MM OD)& LOCK WASHER		
16-016	407-A740-00			1	BRACKET:PLUG-IN BOARD, A5052P-H32(34), T1.0		
16-017	441-A306-02			1	CHASSIS, MAIN:PLUG-IN		
16-018	334-1378-50			1	MARKER, INDENT:MKD SERIAL NO.		

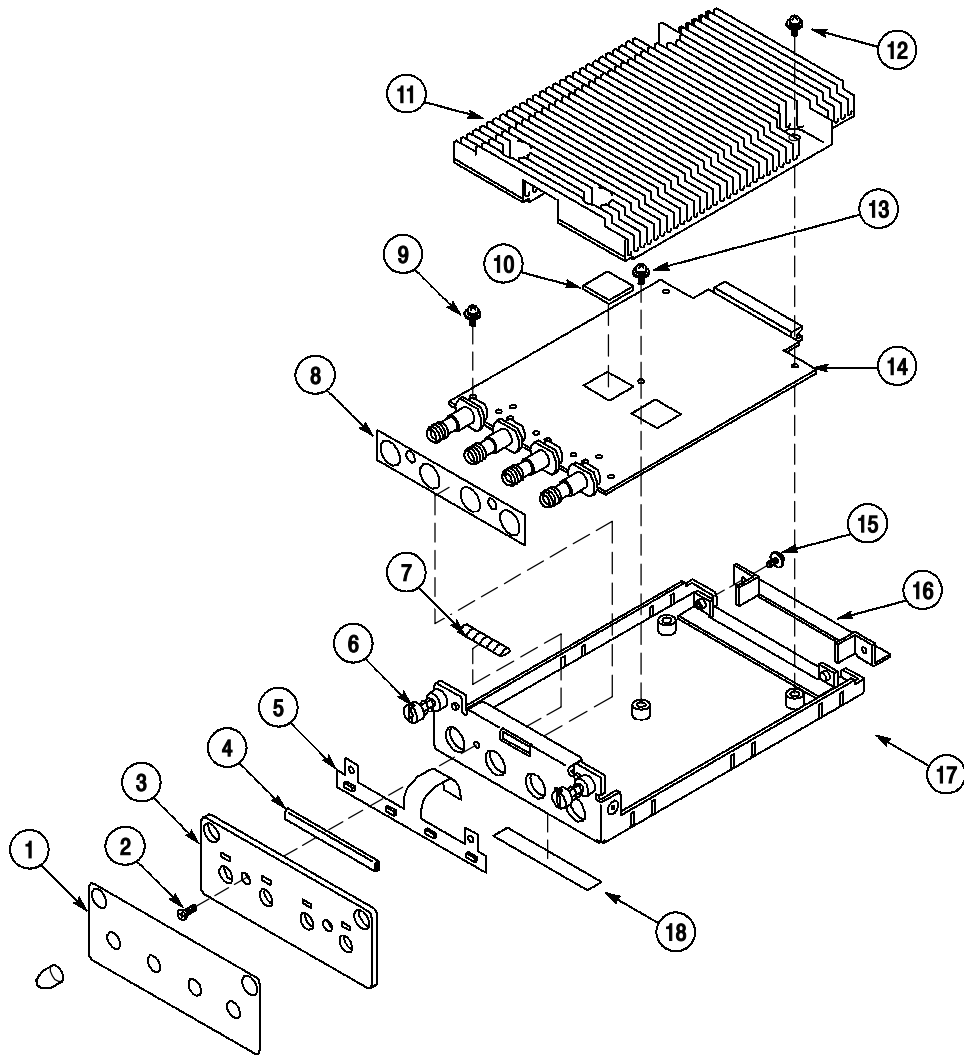

Figure 9-16: DTGM10

Replaceable Mechanical Parts

Replaceable Parts List

Fig. & index number	Tektronix part number	Serial no. effective	Serial no. dis-cont'd	Qty.	Name & description	Mfr. code	Mfr. part number
9-17					DTGM20		
	671-B259-51				A72		
17-001	333-A459-01			1	PANEL, FRONT:DTGM20, POLYCARBONATE		
17-002	211-1039-00			2	SCREW, MACHINE:M2.5X6MM L, FLH, STL, CR PL, CROSS REC		
17-003	386-A873-00			1	SUBPANEL, FRONT:PLUG-IN		
17-004	348-A155-00			5	GASKET, SHIELD:CONDUCTIVE URETHAN FORM, 2MM X 4MM, W/CONDUCTIVE ADHESIVE		
17-005	259-A005-01			1	FLEX CIRCUIT:A80 ON/OFF LED, W/LED		
17-006	214-B284-00			1	FASTNER ASSY:M2.5 SCREW, PRESSMOUNT, SPRING-LOADED		
17-007	348-A156-00			10	GASKET, SHIELD:FINGER TYPE, BE-CU, 8.13MM W X 2.79MM H X 406.4MM L		
17-008	348-A157-00			1	GASKET, SHIELD:CONDUCTIVE SHEET, FOR DTG PLUG-IN		
17-009	211-A151-00			8	SCREW, MACHINE:M2.5X6MM L, PNH, STL, ZN-C, CROSS REC, W/KOGATA-PLAIN & SPLIT WSHR		
17-010	342-A166-00			2	INSULATOR, PLATE:HEAT CONDUCTOR, A70/72, 15MM SQ, T=1MM		
17-011	214-B279-01			1	HEAT SINK:A72 BD		
17-012	211-A242-00			4	SCREW, MACHINE:M3X12MM L, STL, BLK, W/K-PLAIN & SPLIT, KOGATAMARU		
17-013	211-0871-00			1	SCREW, MACHINE:M3X6MM L, PNH, STL, ZN PL, CROSS REC, W/FLAT(7MM OD)& LOCK WASHER		
17-014	671-B259-51			1	CIRCUIT BD ASSY:A72 DTGM20(EDGE2702), 389-B246-xx WIRED		
17-015	211-0871-00			2	SCREW, MACHINE:M3X6MM L, PNH, STL, ZN PL, CROSS REC, W/FLAT(7MM OD)& LOCK WASHER		
17-016	407-A740-00			1	BRACKET:PLUG-IN BOARD, A5052P-H32(34), T1.0		
17-017	441-A306-02			1	CHASSIS, MAIN:PLUG-IN		
17-018	334-1378-50			1	MARKER, INDENT:MKD SERIAL NO.		

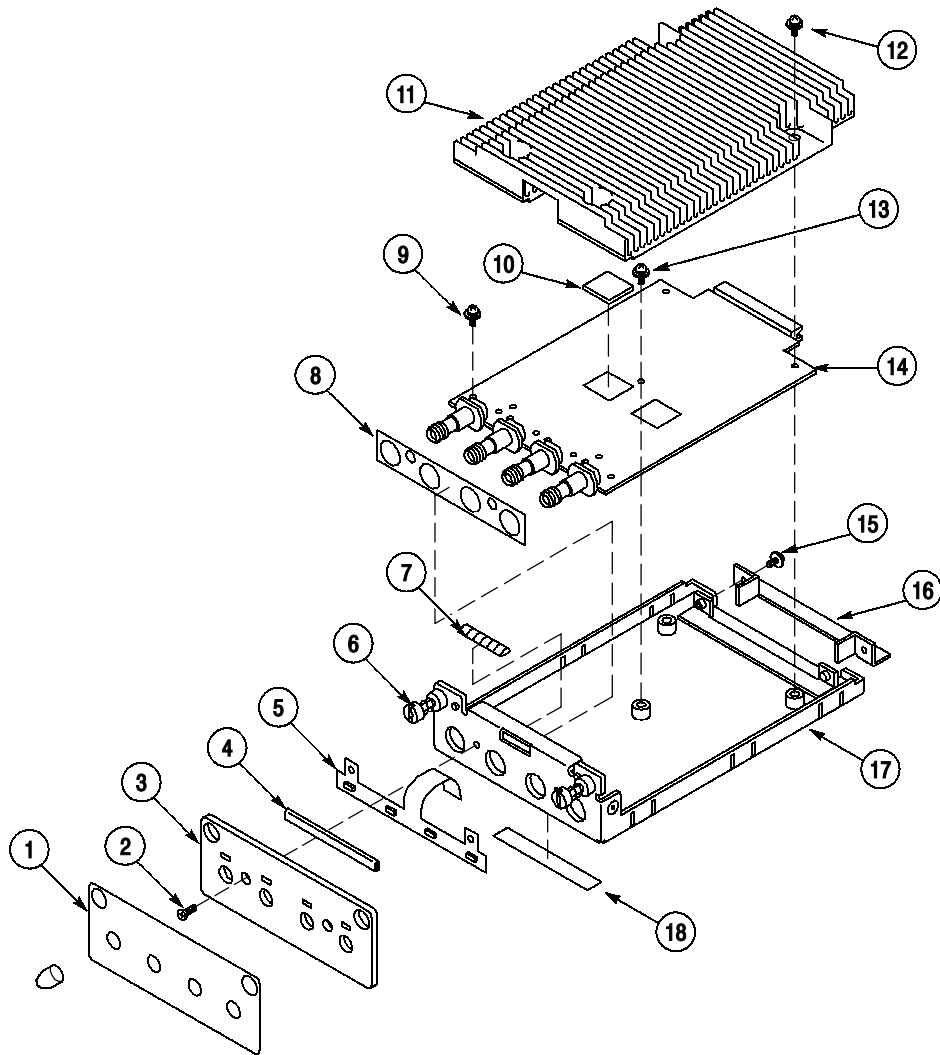

Figure 9-17: DTGM20

Replaceable Mechanical Parts

Replaceable Parts List

Fig. & index number	Tektronix part number	Serial no. effective	Serial no. dis-cont'd	Qty.	Name & description	Mfr. code	Mfr. part number
9-18					DTGM30		
	671-B260-53				A70		
18-001	333-A460-01			1	PANEL, FRONT:DTGM20, POLYCARBONATE		
18-002	211-1039-00			2	SCREW, MACHINE:M2.5X6MM L, FLH, STL, CR PL, CROSS REC		
18-003	386-A873-00			1	SUBPANEL, FRONT:PLUG-IN		
18-004	348-A155-00			5	GASKET, SHIELD:CONDUCTIVE URETHAN FORM, 2MM X 4MM, W/CONDUCTIVE ADHESIVE		
18-005	259-A005-01			1	FLEX CIRCUIT:A80 ON/OFF LED, W/LED		
18-006	214-B284-00			1	FASTNER ASSY:M2.5 SCREW, PRESSMOUNT, SPRING-LOADED		
18-007	348-A156-00			10	GASKET, SHIELD:FINGER TYPE, BE-CU, 8.13MM W X 2.79MM H X 406.4MM L		
18-008	348-A157-00			1	GASKET, SHIELD:CONDUCTIVE SHEET, FOR DTG PLUG-IN		
18-009	211-A151-00			8	SCREW, MACHINE:M2.5X6MM L, PNH, STL, ZN-C, CROSS REC, W/KOGATA-PLAIN & SPLIT WSHR		
18-010	342-A166-00			2	INSULATOR, PLATE:HEAT CONDUCTOR, A70/72, 15MM SQ, T=1MM		
18-011	214-B278-02			1	HEAT SINK:A70 BD		
18-012	211-A242-00			4	SCREW, MACHINE:M3X12MM L, STL, BLK, W/K-PLAIN & SPLIT, KOGATAMARU		
18-013	211-0871-00			1	SCREW, MACHINE:M3X6MM L, PNH, STL, ZN PL, CROSS REC, W/FLAT(7MM OD)& LOCK WASHER		
18-014	671-B260-53			1	CIRCUIT BD ASSY:A70 DTGM30(HSD30), 389-B247-xx WIRED		
18-015	210-A120-00			2	210:WASHER, PLAIN		
18-016	342-A166-00			2	INSULATOR, PLATE:HEAT CONDUCTOR, A70/72, 15MM SQ, T=1MM		
18-017	211-0871-00			2	SCREW, MACHINE:M3X6MM L, PNH, STL, ZN PL, CROSS REC, W/FLAT(7MM OD)& LOCK WASHER		
18-018	407-A740-00			1	BRACKET:PLUG-IN BOARD, A5052P-H32(34), T1.0		
18-019	441-A306-02			1	CHASSIS, MAIN:PLUG-IN		
18-020	334-1378-50			1	MARKER, INDENT:MKD SERIAL NO.		

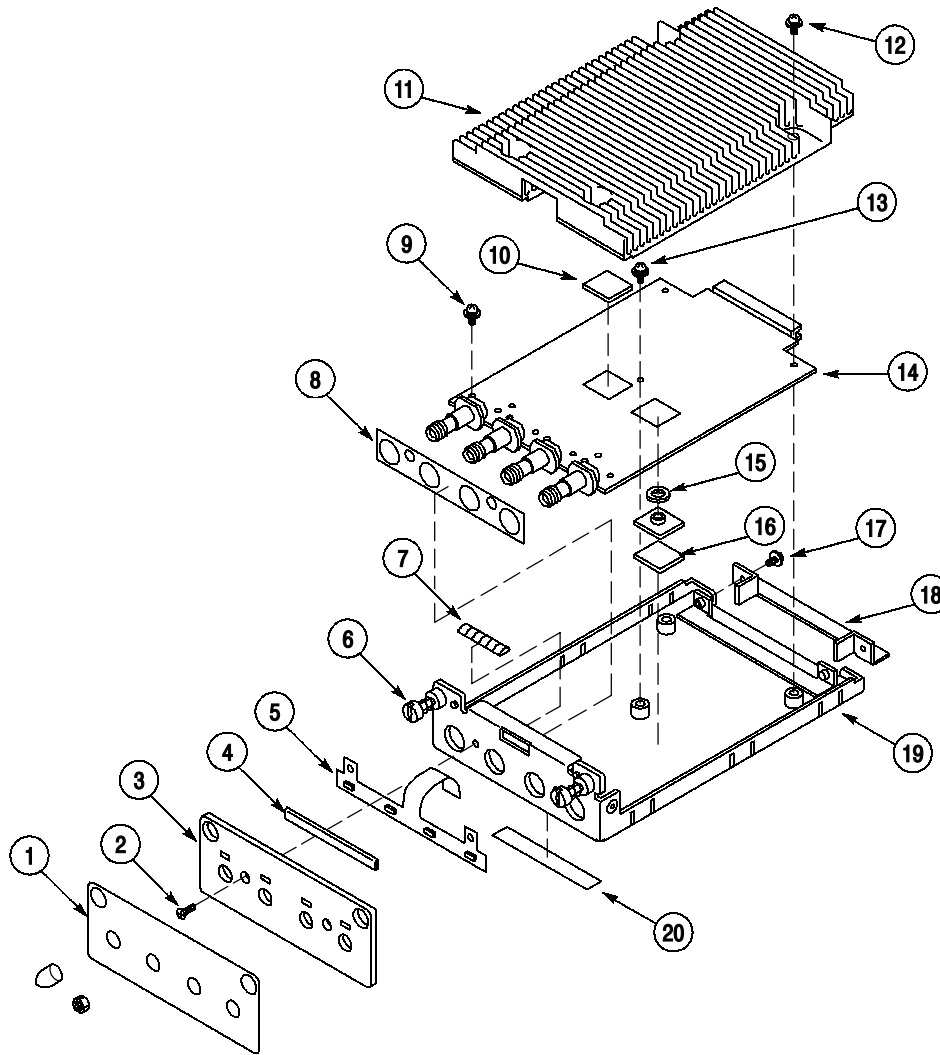

Figure 9-18: DTGM30

Replaceable Parts List

Fig. & index number	Tektronix part number	Serial no. effective	Serial no. dis-cont'd	Qty.	Name & description	Mfr. code	Mfr. part number
9-19					OP1RR (RACK MOUNT)		
19	020-A052-00			1	COMPONENT KIT:FIELD KIT,RACK-MOUNT,DTG5000		
19-1	407-A720-00			1	BRACKET,LEFT: RACK-MOUNT,AL,t2.0mm		
19-2	426-A203-00			2	MOUNT BASE,LEFT RACK-MOUNT,AL,t4.0mm		
19-3	213-A250-00			6	SCREW,MACHINE FM4X8 L,FLH,STL,ZN-C PL,CROSS REC		
19-4	407-A721-00			1	BRACKET,RIGHT: RACK-MOUNT,AL,t2.0mm		

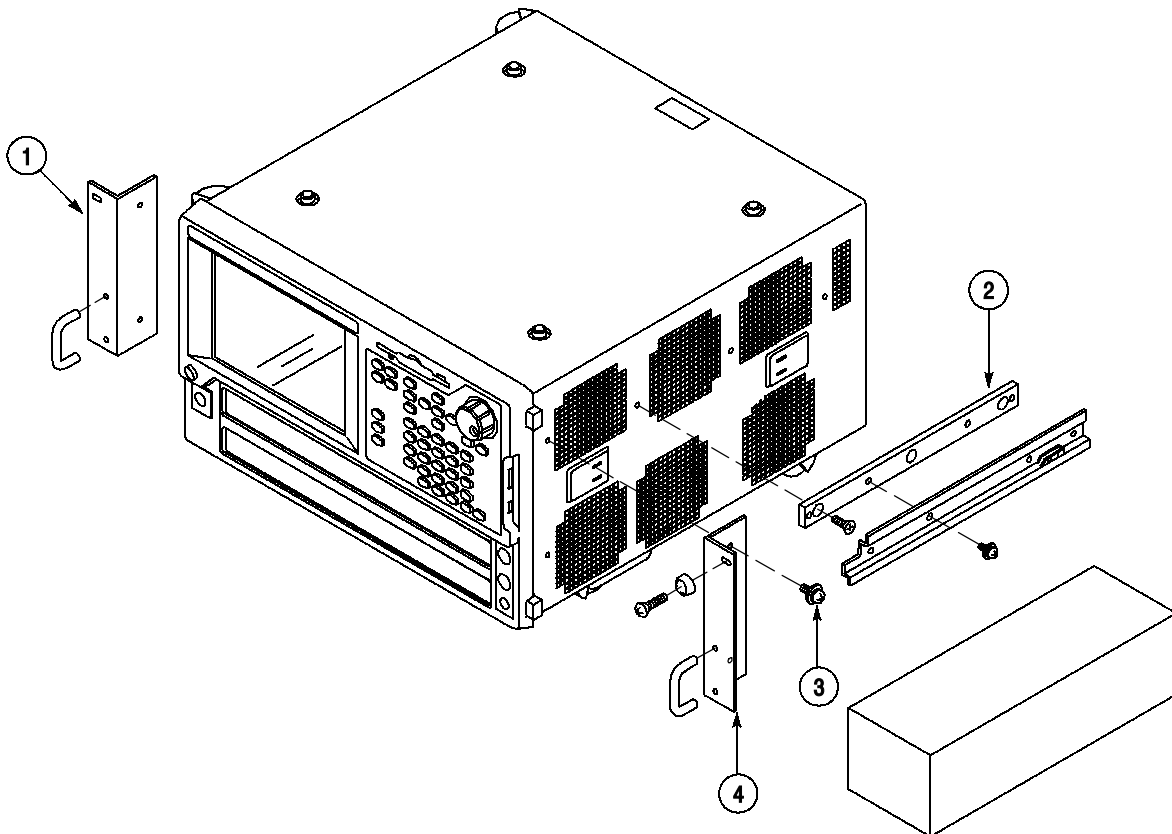

Figure 9-19: Op 1R (Rack Mount)

